



INSTRUCTION MANUAL IM-455
For Steam Turbine Tensioned
Studs and Nuts

Applicable Bolting Connections

A650 Steam Turbine, Stub Shaft to Generator

A63 Steam Turbine to A63 Generator

Applicable GE Ordering Sheet Part Numbers

134T5165P0001

134T5165P0002

305T5129P0001

305T5129P0002

CUSTOMER'S INFORMATION BOX

CONTENTS ARE INDEPENDENT OF RIVERHAWK DOCUMENT CONTROL

GE Power & Water		GENERAL ELECTRIC COMPANY	
<u>VENDOR SUPPLIED</u>			
GE NOT TO REVISE. GE REVISION LEVEL IS SHOWN ON THIS APPLIQUE. THIS DOCUMENT IS FILED UNDER THE GE DRAWING NUMBER.			
THIS DOCUMENT SHALL BE REVISED IN ITS ENTIRETY. ALL SHEETS OF THIS DOCUMENT ARE THE SAME REVISION LEVEL AS INDICATED IN THIS VENDOR SUPPLIED DRAWING APPLIQUE.			
MLJ: _____		_____ OF _____	
GE SIGNATURES	DATE	GE DRAWING NUMBER	REV
CHECKED:		100A1477	
ISSUED:			

The Riverhawk Company reserves the right to update this document without dissemination or notice. The latest revision may be obtained by contacting Riverhawk Company or thru www.riverhawk.com.



Repairs – Rentals
 Field Service

215 Clinton Road
 New Hartford, NY 13413
 Tel: +1 315 768 4855
 Fax: +1 315 768 4941
 Email: info@riverhawk.com

Table of Contents

Section	Description	Page Number
1.0	Cautions and Safety Warnings	3
2.0	Scope and GE Part Number Cross Reference	4
3.0	Quick Checklist	5
4.0	General Preparations	9
5.0	Hardware Set Preparations	11
6.0	Stud and Nut Assembly	14
7.0	Hydraulic Tensioner Equipment Assembly	17
8.0	Assembly of Tensioner on Stud	19
9.0	Stud Tensioning	24
10.0	Thread Locking and Windage Plug Installation	27
11.0	Stud and Nut Removal	30
12.0	Storage Instructions	34
13.0	Frequently Asked Questions	35
14.0	Revision History	38
Appendix A1	EC Declaration of Conformity	39
Appendix A2	UKCA Declaration of Conformity	40
Appendix B1	16-Bolt Tensioning Pattern (ST - GEN) Record Sheet	41



215 Clinton Road
 New Hartford, NY 13413
 Tel: +1 315 768 4855
 Fax: +1 315 768 4941
 Email: info@riverhawk.com

CUSTOMER'S INFORMATION BOX
 CONTENTS ARE INDEPENDENT OF RIVERHAWK DOCUMENT CONTROL

GE DRAWING NUMBER	REV
100A1477	

1.0 Cautions and Safety Warnings

WARNING

Improper tool use and the failure to follow the correct procedures are the primary root causes of tool failures and personal injuries. A lack of training or experience can lead to incorrect hardware installation or incorrect tool use. Only trained operators with careful, deliberate actions should use hydraulic tensioners.

CAUTION

Personal injury and equipment damage can occur if the proper health and safety codes and procedures are not followed. Contact the site's health and safety office to determine all applicable safety rules and regulations.

WARNING

The proper personal protective equipment must be worn at all times.

CAUTION

It is especially important to check the condition of the conical thread used to tension the stud. Thread damage from previous abuse can lead to failure of the stud or tensioning equipment

CAUTION

Riverhawk recommends that the tensioner should be returned to Riverhawk for periodic inspections. Replacement of obsolete tensioners is recommended. Functional upgrades are also recommended. The Riverhawk Service Returns Coordinator should be notified 3-6 months prior to a planned outage to schedule an inspection service.

WARNING

A damaged burst disc must be replaced with a burst disc of the same design and pressure rating. Do not substitute a damaged burst disc with a different disc type, a different pressure rating, or a foreign object.

WARNING

To avoid failure, ensure safety, and proper operation, the tensioner assembly must be installed on a stud in the flange before pressurizing the tensioner. Do not use the tensioner at any pressure unless the tool is installed on a stud in a flange.

CAUTION

Personal injury and equipment damage can occur if the puller screw is not securely engaged with the tapered threads of the stud. Proper engagement is achieved when the puller screw is tight in the stud and the tensioner foot is free to turn.



215 Clinton Road
New Hartford, NY 13413
Tel: +1 315 768 4855
Fax: +1 315 768 4941
Email: info@riverhawk.com

CUSTOMER'S INFORMATION BOX

CONTENTS ARE INDEPENDENT OF RIVERHAWK DOCUMENT CONTROL

GE DRAWING NUMBER	REV
100A1477	

IM-455 Revision F
Page 3 of 41

WARNING

The safety interlock guard must be in place at all times. When the tensioner is pressurized hands must be kept out of designated areas to avoid any potential for personal injury.

CAUTION

Before threading the puller screw into the stud, carefully check the cleanliness of both the stud's and the puller screw's conical threads. Apply a light coat of clean turbine oil or a spray lubricant to the puller screw. This procedure will ease assembly and assure positive mating of the threads before tightening. Do not use "Never Seize" on the conical threads.

CAUTION

Do not tighten the nut while the tool is coming up to pressure; wait until pressure is achieved before attempting to tighten the nut with the spanner ring. If the tool is not properly installed, the tool could jump off the stud while coming up to pressure.

CAUTION

Do not exceed the maximum pressure marked on the tensioner. Excessive pressure can damage the stud and puller screw.

WARNING

FIRE HAZARD: DO NOT heat when tensioner assembly is in place. Personal injury or equipment damage may occur. Use of an Oxy-Acetylene torch is not recommended

WARNING

Do not use a hydraulic tensioner to remove a stud with damaged conical threads.

2.0 Scope and GE Part Number Cross Reference

This document describes the procedure to be used to install the stud, nut and windage plug sets supplied by the Riverhawk Company in the flanges listed on the cover sheet.

The various frame configurations covered in this manual are listed in Sections 2.1 through 2.2 with differences as related to connective hardware defined. Listed also are the pertinent hardware drawings (HF-xxxx). These drawings as well as tooling drawings (HT-xxxx) form part of this manual and should be available to the personnel using the equipment.



215 Clinton Road
New Hartford, NY 13413
Tel: +1 315 768 4855
Fax: +1 315 768 4941
Email: info@riverhawk.com

CUSTOMER'S INFORMATION BOX
CONTENTS ARE INDEPENDENT OF RIVERHAWK DOCUMENT CONTROL

GE DRAWING NUMBER	REV
100A1477	

2.1 A650 Steam Turbine; Stub Shaft to Generator Flange connection

GE Part Number	Riverhawk P/N	GE VENDOC P/N
134T5165P0001	HF-8701	GE 101B0753
134T5165P0002	HF-8701	GE 101B0753

The hydraulic tooling used for installation and removal is Riverhawk HT-9788 (GE 101B0815) which replaces HT-8903 (GE 101B0769). Riverhawk HT-9769 (101B0806) can also be used.

These hardware drawing depicts the stud, nut and windage plug set for the Stub Shaft to Generator flange (2-3/4" size, Qty 16).

2.2 A63 Steam Turbine to A63 Generator Flange connection

GE Part Number	Riverhawk P/N	GE VENDOC P/N
305T5129P0001	HF-9923	GE 101B0807
305T5129P0002	HF-9923	GE 101B0807

The hydraulic tooling used for installation and removal is Riverhawk HT-10058 (GE 101B0809).

These hardware drawing depicts the stud, nut and windage plug set for the Steam Turbine to Generator flange (2-3/4" size, Qty 16).

3.0 Quick Checklist

The following checklist is intended as a summary of the steps needed to use the Riverhawk-supplied equipment. New personnel or those experienced personnel who have not used the Riverhawk equipment recently are encouraged to read the entire manual.

EQUIPMENT INSPECTION

- Check oil level in hydraulic pump.
- Check air pressure at 90psi [6.2 bar] minimum. (For air-driven pumps)
- Check hydraulic hose for damage.
- Test pump.



215 Clinton Road
 New Hartford, NY 13413
 Tel: +1 315 768 4855
 Fax: +1 315 768 4941
 Email: info@riverhawk.com

CUSTOMER'S INFORMATION BOX
 CONTENTS ARE INDEPENDENT OF RIVERHAWK DOCUMENT CONTROL

GE DRAWING NUMBER	REV
100A1477	

- Inspect tensioner for any damage.

NUT AND STUD PREPARATION

- Inspect studs, nuts and windage plugs for any damage.
- Clean the studs, nuts and windage plugs.
- Measure and record stud lengths. (VERY IMPORTANT)
- Lubricate the nut's threads and nut face with clean turbine oil or spray lubricant. Lubricate the stud's threads with clean turbine oil or spray lubricant.
- Install studs and nuts into the flange and set the stud stick-out dimensions per the Riverhawk hardware drawing from section 2.
- With Allen wrench in backside of stud, firmly seat backside nut using spanner ring and pin wrench.
- Verify stick-out measurement (**VERY IMPORTANT**)

TENSIONING (Bolt Installation)

- Check tensioner drawing for correct parts and part numbers.
- Apply a light coat of clean turbine oil or spray lubricant to the puller screw. **DO NOT USE "NEVER SEIZE" ON THE CONICAL THREADS.**
- Install the spanner ring onto the nut.
- Thread the puller screw into the stud.
- Insert an Allen wrench into the back side of the stud.
- Insert another Allen wrench into the puller screw. While holding the stud still, tighten the puller screw until hand tight and then loosen the puller screw 1/2 of a turn. Retighten the puller screw and leave hand tight. **DO NOT BACK OFF PULLER SCREW.**



215 Clinton Road
New Hartford, NY 13413
Tel: +1 315 768 4855
Fax: +1 315 768 4941
Email: info@riverhawk.com

CUSTOMER'S INFORMATION BOX
CONTENTS ARE INDEPENDENT OF RIVERHAWK DOCUMENT CONTROL

GE DRAWING NUMBER	REV
100A1477	

- Slide the foot assembly over the puller screw and orientate the foot into position.
- Thread the tensioner onto puller screw until it stops. There should be a 1/16" to 3/16" gap between the foot and tensioner.
- Place the guard over the tensioner and position guide pin into the hole in the backside of the stud.
- Tighten the guard's knurled interlock fitting by hand until it presses firmly against tensioner (no gap).
- Push the center of the interlock fitting towards the tensioner while pulling back on the fitting's pull tabs until it locks onto the tensioner and release the pull tabs.
- Connect the hydraulic pump to the tensioner and tension to 50%. Consult manual for correct pressure.
- Use the pin wrench to turn the spanner ring to firmly tighten nut with 20 ft·lbs [27 N·m] of torque.
- Release pressure and allow the tensioner to fully retract.
- Disconnect the hose and release the interlock fitting by pushing the center of the interlock fitting towards the tensioner while pulling back on the fitting's pull tabs.
- Loosen the knurled interlock fitting and remove the guard.
- Unscrew the tensioner from the puller screw.
- Remove the foot, puller screw and spanner ring.
- Move to the next stud in the pattern. Tension all studs to 50% before proceeding to final pressure.
- Repeat above steps at final pressure.
- Measure final stud length and record on stretch datasheets. Calculate final stretch measurement.
- Torque the nuts' set screws.



215 Clinton Road
New Hartford, NY 13413
Tel: +1 315 768 4855
Fax: +1 315 768 4941
Email: info@riverhawk.com

CUSTOMER'S INFORMATION BOX
CONTENTS ARE INDEPENDENT OF RIVERHAWK DOCUMENT CONTROL

GE DRAWING NUMBER	REV
100A1477	

- Install the windage plugs and torque their set screws.

DETENSIONING (Stud Removal)

- Loosen the windage plugs' set screws and remove the windage plugs from the studs.
- Loosen nuts' set screws
- Inspect and clean studs' conical threads. **Do not continue until ALL debris is removed from the threads!** See instruction manual IM-220. **Do not try to use the tensioner to remove a damaged stud!**
- Apply a light coat of clean turbine oil or spray lubricant to the puller screw. **DO NOT USE "NEVER SEIZE" ON THE CONICAL THREADS.**
- Install the spanner ring onto the nut.
- Thread the puller screw into the stud.
- Insert an Allen wrench into the puller screw. Tighten the puller screw until hand tight and then loosen the puller screw 1/2 of a turn. Retighten the puller screw and leave hand tight. **DO NOT BACK OFF PULLER SCREW.**
- Slide the foot assembly over the puller screw and orientate the foot into position.
- Thread the tensioner onto puller screw until it stops. There should be a 1/16" to 3/16" gap between the foot and tensioner.
- Place the guard over the tensioner and position guide pin into the hole in the backside of the stud.
- Tighten the guard's knurled interlock fitting by hand until it presses firmly against tensioner (no gap).
- Push the center of the interlock fitting towards the tensioner while pulling back on the fitting's pull tabs until it locks onto the tensioner and release the pull tabs.
- Connect the hydraulic pump to the tensioner and tension to final pressure. Consult manual for correct pressure.



215 Clinton Road
New Hartford, NY 13413
Tel: +1 315 768 4855
Fax: +1 315 768 4941
Email: info@riverhawk.com

CUSTOMER'S INFORMATION BOX
CONTENTS ARE INDEPENDENT OF RIVERHAWK DOCUMENT CONTROL

GE DRAWING NUMBER	REV
100A1477	

- Loosen nut with the spanner ring and pin wrench approximately ½ of a turn.
- Release pressure and allow the tensioner to fully retract.
- Disconnect the hose and release the interlock fitting by pushing the center of the interlock fitting towards the tensioner while pulling back on the fitting's pull tabs.
- Loosen the knurled interlock fitting and remove the guard.
- Unscrew the tensioner cylinder from the puller screw.
- Remove the foot, puller screw, and spanner ring. It may be necessary to insert an Allen wrench into the backside of the stud to remove the puller screw.
- Move to next stud in pattern

4.0 General Preparations

Read and understand all instructions before installing and tensioning studs.

Operators should be trained or have previous experience using Riverhawk tensioning equipment. Training will minimize the chance of improper use of the equipment.

The hydraulic tooling including the hydraulic hoses should be inspected prior to use. Inspection guidelines are listed in the following sub-sections.

This equipment produces very high hydraulic pressures and very high forces. Operators must exercise caution and wear the appropriate personal protective equipment when handling and operating the hydraulic tooling.

High-pressure oil from the hydraulic pump pressurizes the tensioner which generates a very large force that actually stretches the stud. As the stud is stretched the nut lifts off the flange. The nut is then turned by hand using the supplied spanner ring. Once the nut is tight against the flange, the pressure in the tensioner is released. The hardware is now clamping the flange together.



215 Clinton Road
New Hartford, NY 13413
Tel: +1 315 768 4855
Fax: +1 315 768 4941
Email: info@riverhawk.com

CUSTOMER'S INFORMATION BOX
CONTENTS ARE INDEPENDENT OF RIVERHAWK DOCUMENT CONTROL

GE DRAWING NUMBER	REV
100A1477	

4.1 Machine Preparation

The flange to be tensioned must be fully closed prior to positioning of studs in the flanges. Turning the rotor shafts is not required, but may be useful. Also, it will be advantageous to remove as many obstructions as possible from the flange area, such as speed probes, shipping plates, and conduit.

4.2 Hardware – Balance

The studs are supplied in component balanced sets. A stud can be exchanged with another in its set without affected the overall balance of the equipment. Do not exchange a stud from one set with another stud from a different set. When shipped from Riverhawk, the studs are not assigned to any specific hole in the flange; this is optional and can be done at the installation site. The set size is determined by the relevant GE order drawing (see section 2.0).

The nuts are supplied in component balanced sets. A nut can be exchanged with another in its set without affecting the overall balance of the equipment. Do not exchange a nut from one set with another nut from a different set. When shipped from Riverhawk, the nuts are not assigned to any specific hole in the flange; this is optional and can be done at the installation site. The set size is determined by the relevant GE order drawing (see section 2.0).

The windage plugs are supplied in component balanced sets. A windage plug can be exchanged with another in its set without affecting the overall balance of the equipment. Do not exchange a windage plug from one set with another windage plug from a different set. When shipped from Riverhawk, the windage plugs are not assigned to any specific hole in the flange; this is optional and can be done at the installation site. The set size is determined by the relevant GE order drawing (see section 2.0).

A weight balance certification is supplied with each order. Store this certification in an appropriate location as it will be needed for the purchase of replacement equipment.

4.3 Tensioner – Care and Handling

When not in use, the tensioner shall be maintained in a clean environment and all caps and plugs for hydraulic openings and fittings must be in place.

When in use, the tensioner shall be protected from sand and grit.

See section 12 for long term storage requirements.



215 Clinton Road
New Hartford, NY 13413
Tel: +1 315 768 4855
Fax: +1 315 768 4941
Email: info@riverhawk.com

CUSTOMER'S INFORMATION BOX
CONTENTS ARE INDEPENDENT OF RIVERHAWK DOCUMENT CONTROL

GE DRAWING NUMBER	REV
100A1477	

4.4 Hand Tools

Several hand wrenches and micrometers may be required to perform installation and measurement of the studs:

- 5/8" Wrench
- 3/4" Wrench
- 13/16" Wrench
- A set of Allen Wrenches
- 3' to 4' Breaker Bar
- 10" to 11" Micrometer or Caliper

4.5 Special Tools

- | | |
|--------------------------|--|
| Hydraulic Tensioner Kit: | HT-9788 Hydraulic Tensioner, 2-3/4"
(Reference GE VENDOC 101B0815) |
| | HT-9769 Hydraulic Tensioner, 2-3/4"
Upgraded HT-8903
(Reference GE VENDOC 101B0806) |
| | HT-8903 Hydraulic Tensioner, 2-3/4"
Replaced by HT-9788
(Reference GE VENDOC 101B0769) |
| | HT-10058 Hydraulic Tensioner, 2-3/4"
(Reference GE VENDOC 101B0809) |
| Hydraulic Pump Kit: | AP-6048 Air-Operated Hydraulic Pump
(Reference GE VENDOC 269B8768) |

CAUTION

Riverhawk recommends that the tensioners be returned to Riverhawk for periodic inspections. Replacement of obsolete tensioners is recommended. Functional upgrades are also recommended. The Riverhawk Service Returns Coordinator should be notified 3-6 months prior to a planned outage to schedule an inspection service.

5.0 Hardware Set Preparations



215 Clinton Road
New Hartford, NY 13413
Tel: +1 315 768 4855
Fax: +1 315 768 4941
Email: info@riverhawk.com

CUSTOMER'S INFORMATION BOX
CONTENTS ARE INDEPENDENT OF RIVERHAWK DOCUMENT CONTROL

GE DRAWING NUMBER	REV
100A1477	

5.1 Nut Preparation

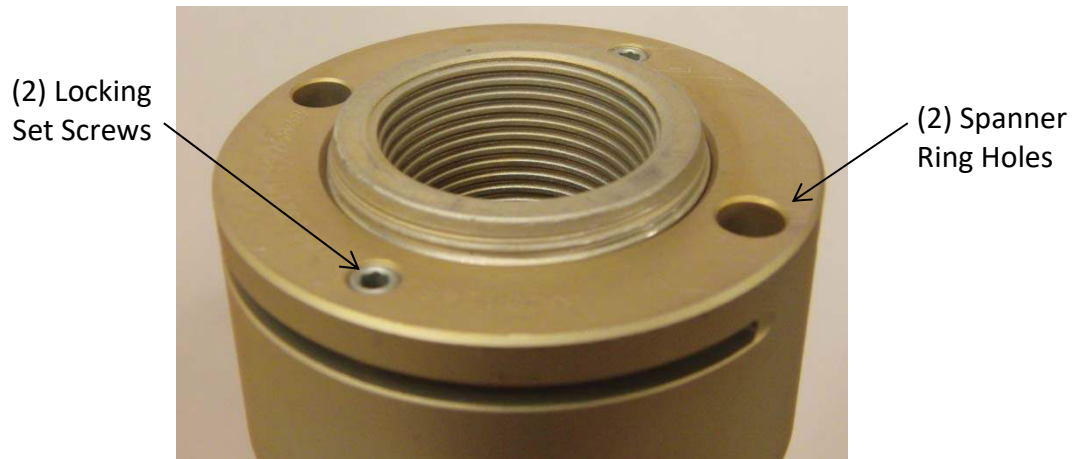

Picture 5A - Riverhawk Locknut

If there is any visible damage on a nut, do not use the part and contact the General Electric or Riverhawk Company for a replacement part. Please be prepared to supply the turbine number, weight certification, and digital photographs for evaluation.

5.1.1 Nut Cleaning - New Installations

For new installations, the nuts should come sealed from the factory and will need no cleaning.

5.1.2 Nut Cleaning - Old Installations

Previously installed nuts require cleaning as follows: Wire brush using a petroleum-based solvent to remove any foreign material on the threads. Clean mating faces with a petroleum based solvent to remove any foreign material.

5.2 Stud Preparation

Check the stud for any visible damage. If there is any visible damage, do not use the stud and contact the Riverhawk Company for a replacement stud. Please be prepared to supply the turbine number, weight certification, and digital photographs for evaluation.

CAUTION

It is especially important to check the condition of the conical thread used to tension the stud. Thread damage from previous abuse can lead to failure of the stud or tensioning equipment.



215 Clinton Road
New Hartford, NY 13413
Tel: +1 315 768 4855
Fax: +1 315 768 4941
Email: info@riverhawk.com

CUSTOMER'S INFORMATION BOX
CONTENTS ARE INDEPENDENT OF RIVERHAWK DOCUMENT CONTROL

GE DRAWING NUMBER	REV
100A1477	

IM-455 Revision F
Page 12 of 41

The conical threads of each stud must be clean of grit and dirt before installation or removal. This ensures the proper seating of the puller screw.

5.2.1 Stud Cleaning - New Installations

For new installations, the studs should come sealed from the factory and will need no cleaning.

5.2.2 Stud Cleaning - Old Installations

Previously installed studs may require cleaning. Clean internal conical threads should have a bright and shiny appearance.

If cleaning is required, follow these steps:

1. Blow out the threads with compressed air to remove loose debris and dry conical threads. Do not apply a solvent or other cleaning solution to the threads as this may chemically attack the stud.
2. Use Stud Cleaning Kit, GT-4253 or a similar 1" diameter Brass power brush.



Picture 5B - Brass Power Brush

3. Insert the brush into an electric drill and set drill to run in a counterclockwise direction at high speed.
4. Work the drill in a circular motion while moving the brush in and out to clean all of the threads. Try not to hold the brush in one place too long, so as not to remove the stud's protective coating.
5. Blow out the threads with compressed air to remove loosened debris.
6. Visually inspect threads for cleanliness. Threads should be bright and shiny.
7. Repeat if any dirt can be seen in the threads.
8. Verify threads are clean by using a dental pick to lightly scrape the root of the thread. If additional material comes loose, repeat cleaning process.



215 Clinton Road
New Hartford, NY 13413
Tel: +1 315 768 4855
Fax: +1 315 768 4941
Email: info@riverhawk.com

CUSTOMER'S INFORMATION BOX
CONTENTS ARE INDEPENDENT OF RIVERHAWK DOCUMENT CONTROL

GE DRAWING NUMBER	REV
100A1477	

IM-455 Revision F
Page 13 of 41

9. Inspect threads for any damage that may have been caused by previous installation.
10. Do **not** apply “Never Seize” to the stud’s threads.
11. Finish the cleaning process by rinsing in a volatile solvent such as acetone and allow the stud to dry.

5.3 Stud Length Measurement

Measure and record the initial lengths of the studs. The following suggestions will improve your results.

- **Plan to start and finish any flange in the same day.**
- **Studs and flange must be at the same temperature.**
- **Number each stud with a marker for later stretch measurement tracking.**
- **Mark the location of measurement on stud end with a permanent marker.**
- **Measure each stud to nearest 0.001 inch (.01 mm).**
- **Record each measurement on the supplied record sheets.**
- **Do not allow the measuring instruments to sit in the sun.**
- **The same person should make all measurements.**

6.0 Stud and Nut Assembly

Refer to the hardware assembly drawing (HF-xxxx) listed in Section 2.0 of the manual.

1. Lubricate the nut’s threads and nut face with clean turbine oil or spray lubricant.
2. Lubricate the stud’s threads with clean turbine oil or spray lubricant.
3. Assemble the frontside nut to the internal, conical thread end of the stud.
4. Slide the stud and nut into the flange as shown in Figure 6A or 6B.
5. Install the other nut on the backside.



215 Clinton Road
New Hartford, NY 13413
Tel: +1 315 768 4855
Fax: +1 315 768 4941
Email: info@riverhawk.com

CUSTOMER'S INFORMATION BOX
CONTENTS ARE INDEPENDENT OF RIVERHAWK DOCUMENT CONTROL

GE DRAWING NUMBER	REV
100A1477	

IM-455 Revision F
Page 14 of 41

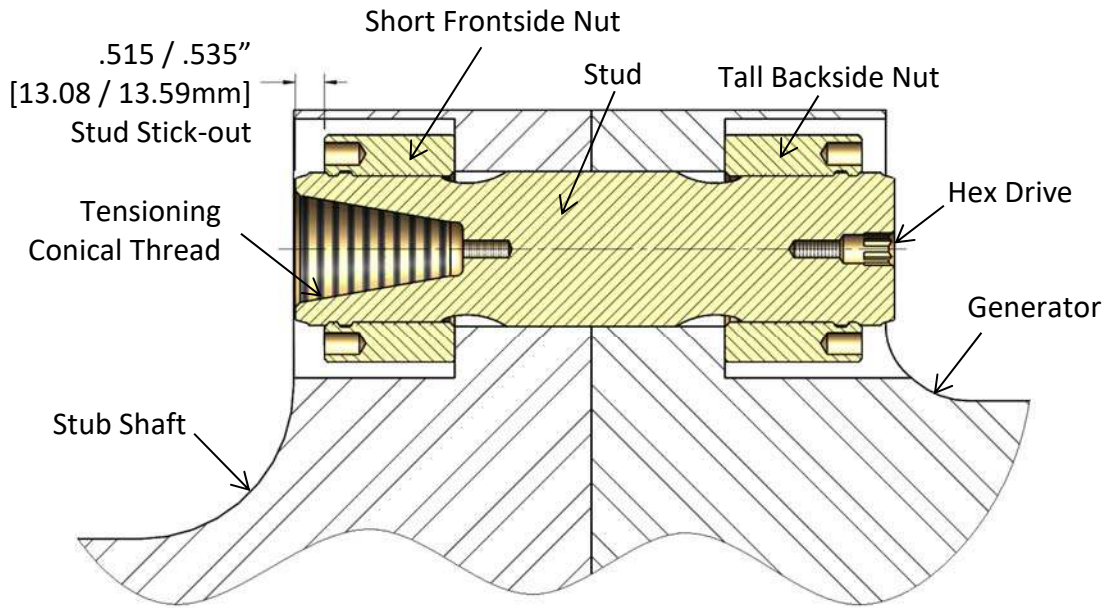

Figure 6A – Cross-section View of A650 Stub Shaft to Generator
(Note: Actual Geometry of the Flanges May Vary)

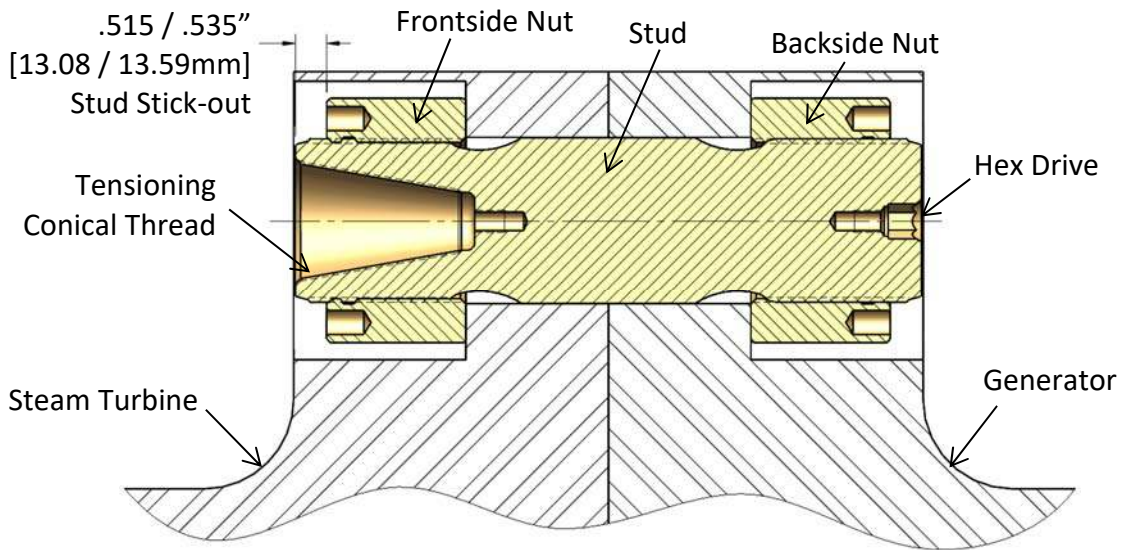

Figure 6B – Cross-section View of A63 Steam Turbine to A63 Generator
(Note: Actual Geometry of the Flanges May Vary)



215 Clinton Road
New Hartford, NY 13413
Tel: +1 315 768 4855
Fax: +1 315 768 4941
Email: info@riverhawk.com

CUSTOMER'S INFORMATION BOX
CONTENTS ARE INDEPENDENT OF RIVERHAWK DOCUMENT CONTROL

GE DRAWING NUMBER	REV
100A1477	

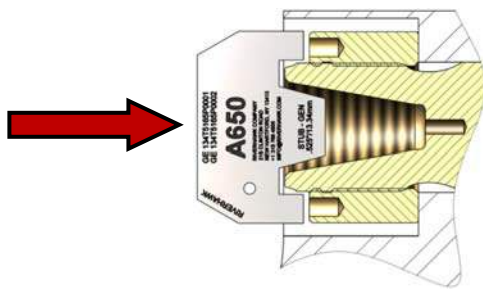

Picture 6C – Use of A650 Stick-Out Gage

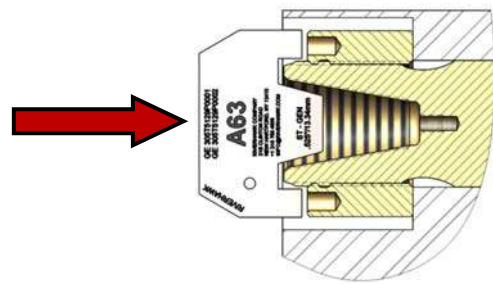

Picture 6D – Use of A63 Stick-Out Gage



Picture 6E – Use of Drop Gage to measure stick-out



Picture 6F – Use of Calipers to measure stick-out

6. Adjust the nut/stud assembly so that the stud sticks out (protrudes) from the face of the nut the amount shown. Best practice is to verify the stud stick-out dimension with the hardware set drawing for your application (see section 2). If you don't have a hardware set drawing, it can be found in the GE Vendocs system or contact Riverhawk Company.

SETTING THE STUD STICK-OUT IS CRITICAL FOR PROPER TENSIONER OPERATION. A metal stick-out gage may be provided with the tensioner to assist the operator in setting the protrusion dimension.

7. With Allen wrench in backside of stud, firmly seat backside nut using spanner ring and pin wrench.
8. Recheck the stud stick-out length. If the stick-out length does not match the hardware drawing, adjust the nuts as necessary.
9. Measure and record starting stud installation gage readings.



215 Clinton Road
 New Hartford, NY 13413
 Tel: +1 315 768 4855
 Fax: +1 315 768 4941
 Email: info@riverhawk.com

CUSTOMER'S INFORMATION BOX
 CONTENTS ARE INDEPENDENT OF RIVERHAWK DOCUMENT CONTROL

GE DRAWING NUMBER	REV
100A1477	

7.0 Hydraulic Tensioner Equipment Assembly

7.1 Hydraulic Equipment Inspection

7.1.1 Hydraulic Tensioner Inspection

CAUTION

Riverhawk recommends that the tensioner be returned to Riverhawk for periodic inspections. Replacement of obsolete tensioners is recommended. Functional upgrades are also recommended. The Riverhawk Service Returns Coordinator should be notified 3-6 months prior to a planned outage to schedule an inspection service.

This tensioner does not require bleeding. See section 8.3

WARNING

To avoid failure, ensure safety, and proper operation, the tensioner assembly must be installed on a stud in the flange before pressurizing the tensioner. Do not use the tensioner at any pressure unless the tool is installed on a stud in a flange.

Clean puller screw and check for any debris and dents.

Inspect the tensioner guard for any signs of damage including cracked welds. Any guards modified in the field should be replaced. Bent guards should be replaced. Also, be sure the rubber pad is in place on the guard, if missing, replace.

Inspect the outside of the tensioner for discoloration patterns that may indicate submersion and internal damage.

Perform an inventory of the loose equipment supplied with the tensioner. An inventory list is provided on the tensioner's technical drawing (Riverhawk HT-xxxx listed in section 2.0 and 4.5). Replacement parts are available from Riverhawk.

7.1.1.1 Hydraulic Tensioner's Burst Disc Replacement

The hydraulic tensioner's burst disc is a key element in the overall safe use of the hydraulic tensioner. The burst disc's location is shown on the tensioner's technical drawing (Riverhawk HT-xxxx listed in section 2.0 and 4.5).

Each tensioner is shipped from our factory with one burst disc already installed in the tensioner and with another spare disc for field replacement. Extra burst discs are available from Riverhawk for replacement purposes.



215 Clinton Road
New Hartford, NY 13413
Tel: +1 315 768 4855
Fax: +1 315 768 4941
Email: info@riverhawk.com

CUSTOMER'S INFORMATION BOX
CONTENTS ARE INDEPENDENT OF RIVERHAWK DOCUMENT CONTROL

GE DRAWING NUMBER	REV
100A1477	

IM-455 Revision F
Page 17 of 41

To replace a damaged burst disc:

1. Remove the hydraulic port's dispersion nut, compression ring, and damaged burst disc.
2. Discard the damaged burst disc.
3. Clean the dispersion nut, compression ring, new burst disc, and the hydraulic port with a solvent to ensure a dirt-free installation.
4. Reassemble new burst disc, compression ring, and dispersion nut into the same hydraulic port.

Warning

A damaged burst disc must be replaced with a burst disc of the same design and pressure rating. Do not substitute a damaged burst disc with a different disc type, a different pressure rating, or a foreign object.

7.1.2 Hydraulic Pump Kit Inspection

Refer to the Hydraulic Pump Kit Instruction Manual, IM-293 (GE VENDOC 373A4058). The latest revision may be obtained by contacting Riverhawk Company or from www.riverhawk.com.

7.2 The 3/8" High Pressure Fitting Assembly

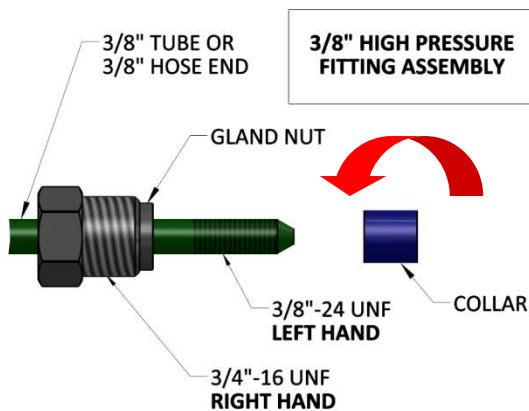

Illustration 1

The Riverhawk hydraulic hose may use a 3/8" High Pressure Fitting to connect to a tensioner. The hose connector is made from a three piece assembly: a gland nut, a collar, and a 3/8" tube or 3/8" hose end. (See Illustration 1)

To assembly the fitting, slide the gland nut over the 3/8" tube or 3/8" hose end. Turn the collar counter-clockwise (**left hand** thread) on to the tube or hose end as shown in Illustration 1.



215 Clinton Road
 New Hartford, NY 13413
 Tel: +1 315 768 4855
 Fax: +1 315 768 4941
 Email: info@riverhawk.com

CUSTOMER'S INFORMATION BOX
 CONTENTS ARE INDEPENDENT OF RIVERHAWK DOCUMENT CONTROL

GE DRAWING NUMBER	REV
100A1477	

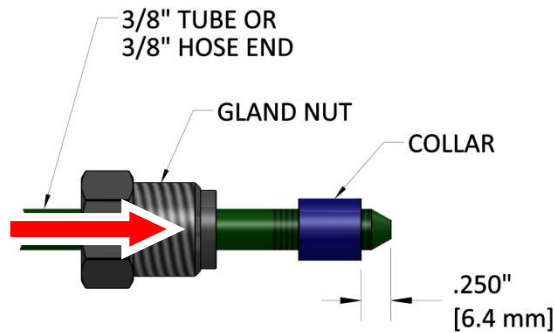

Illustration 2

The collar should be placed .250" (6.4 mm) from the tip of the cone. (See Illustration 2) It may be necessary to adjust this collar with a set of vise-grip pliers. Be careful to not strip the threads off the tube or hose end.

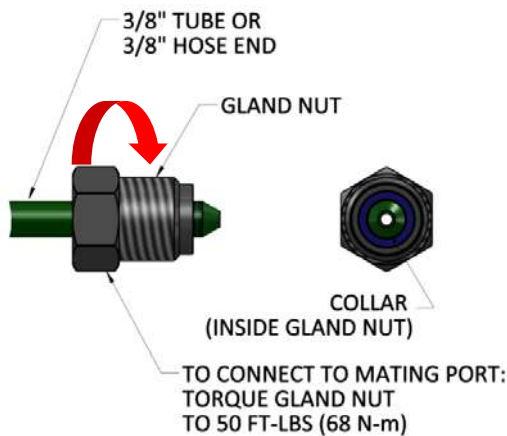

Illustration 3

Slide the gland nut down over the collar. (See Illustration 3) Insert the 3/8" tube or 3/8" hose end into tensioner or hydraulic pump. While firmly holding the tube or hose end to stop it from rotating, turn the gland nut clockwise (**right hand** thread) and torque the gland nut to 50 FT-LBS (68 N-m).

Tips:

- Make sure all parts are clean and free from debris.
- Protect the cone on the end of the 3/8" tube or 3/8" hose end from scratches as this is the sealing surface.
- Replace red plastic caps when finished to protect the threads and cone.

8.0 Assembly of Tensioner on a Stud

The tensioner used in this application can be identified by its ORANGE safety guard. If the tensioner's safety guard is YELLOW, a different set of instructions are required. Consult the Riverhawk factory for assistance.

8.1 Handling of the Tensioner

The tensioner used in this application is designed to require no special lifting instructions. Do not drop any part of the tensioner on the operator or other nearby personnel.



215 Clinton Road
 New Hartford, NY 13413
 Tel: +1 315 768 4855
 Fax: +1 315 768 4941
 Email: info@riverhawk.com

CUSTOMER'S INFORMATION BOX
 CONTENTS ARE INDEPENDENT OF RIVERHAWK DOCUMENT CONTROL

GE DRAWING NUMBER	REV
100A1477	

8.2 Kit Assembly

Connect the hydraulic hose from the hydraulic pump to the tensioner.

Refer to the hardware assembly drawing (HF-xxxx) listed in Section 2.0 of this manual and the tensioner assembly drawing (HT-xxxx) listed in Section 4.5 of this manual to determine how the tensioner must be assembled on the flange for its correct operation.

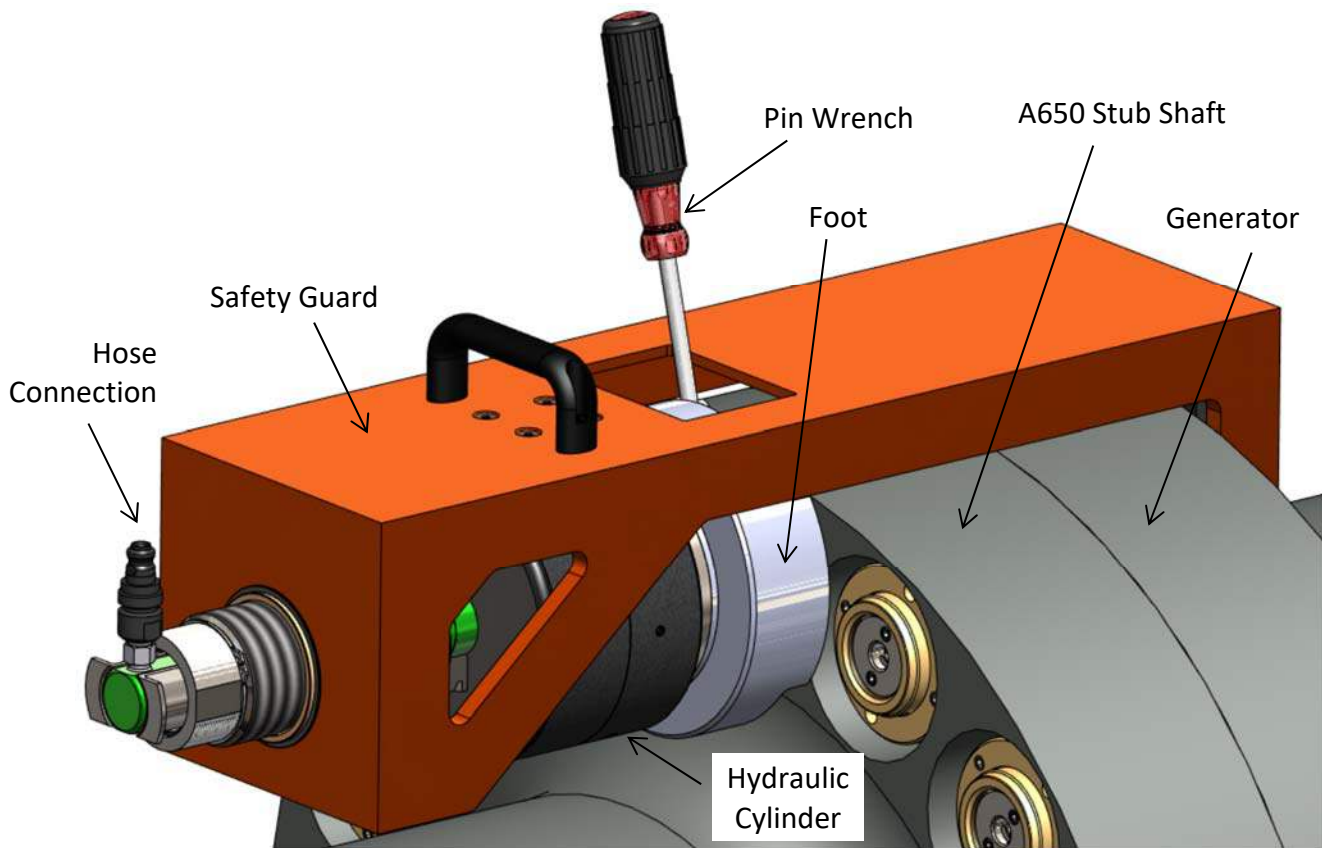

**Picture 8A – Features of the Hydraulic Tensioner HT-9788/HT-9769/HT-8903
(Note: Flange Details may Vary)**



215 Clinton Road
New Hartford, NY 13413
Tel: +1 315 768 4855
Fax: +1 315 768 4941
Email: info@riverhawk.com

CUSTOMER'S INFORMATION BOX
CONTENTS ARE INDEPENDENT OF RIVERHAWK DOCUMENT CONTROL

GE DRAWING NUMBER	REV
100A1477	

IM-455 Revision F
Page 20 of 41

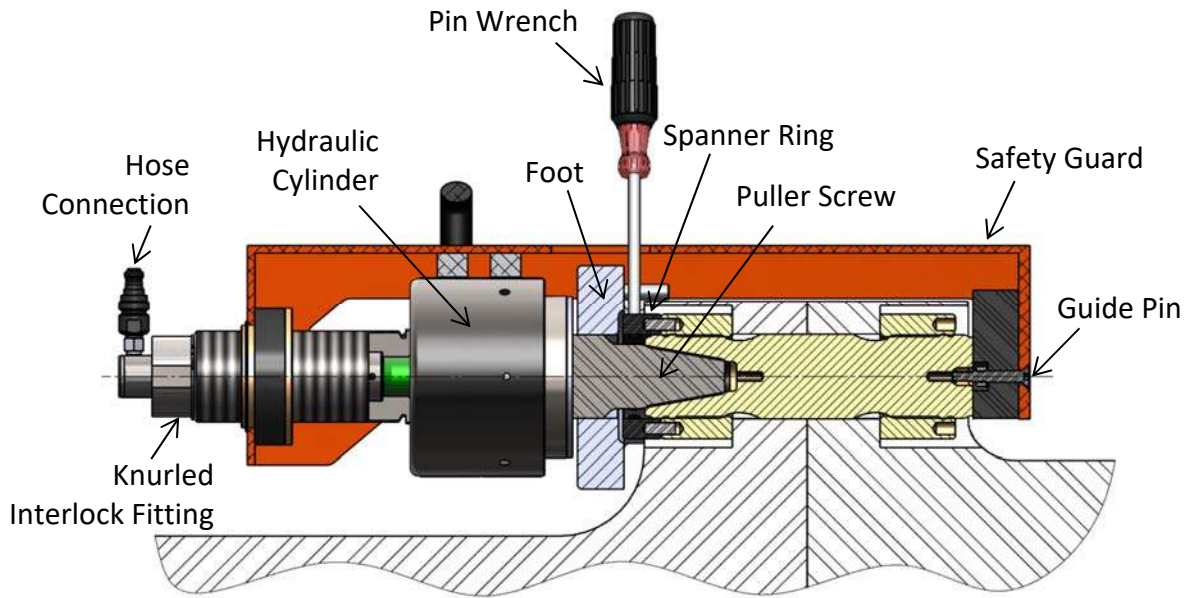

**Figure 8B – Cutaway view of Hydraulic Tensioner HT-9788/HT-9769/HT-8903
(Note: Flange Details May Vary)**

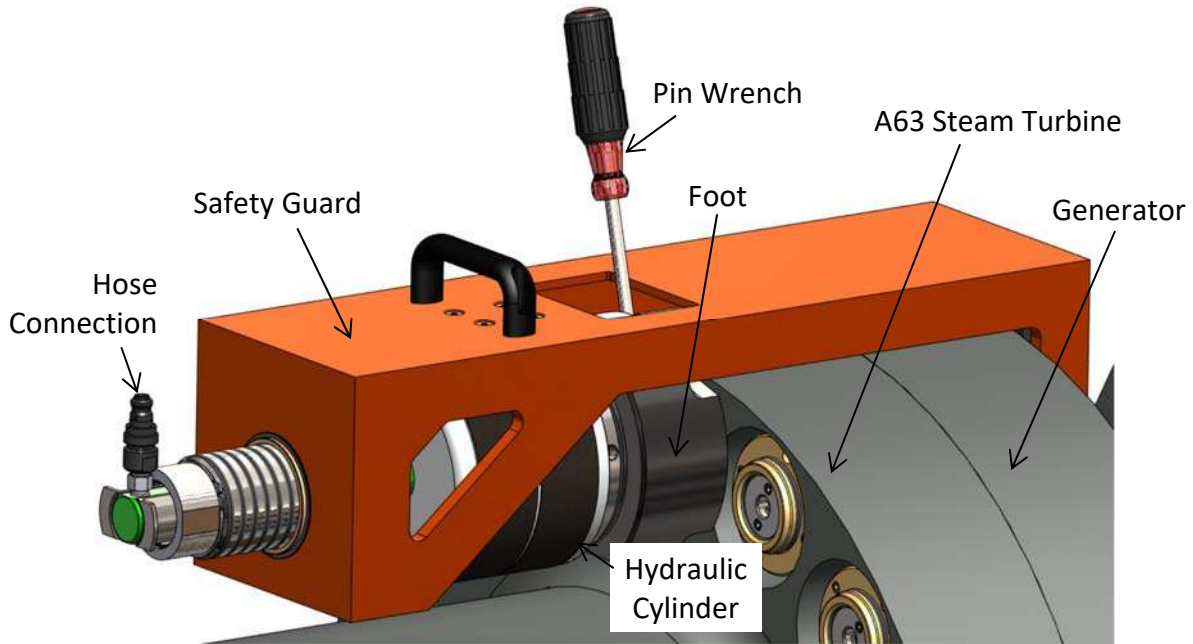

**Picture 8C – Features of the Hydraulic Tensioner HT-10058
(Note: Flange Details may Vary)**

CUSTOMER'S INFORMATION BOX
CONTENTS ARE INDEPENDENT OF RIVERHAWK DOCUMENT CONTROL

GE DRAWING NUMBER	REV
100A1477	



215 Clinton Road
New Hartford, NY 13413
Tel: +1 315 768 4855
Fax: +1 315 768 4941
Email: info@riverhawk.com

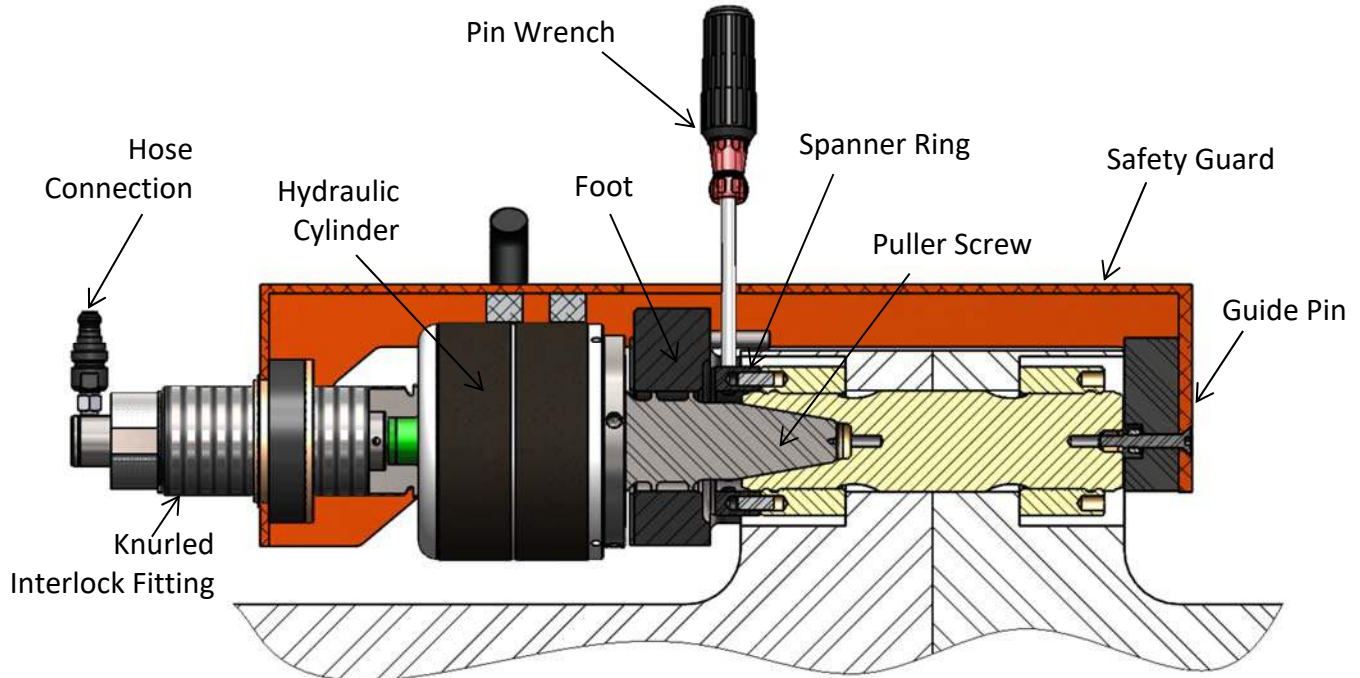

**Figure 8D – Cutaway view of Hydraulic Tensioner HT-10058
(Note: Flange Details May Vary)**

Note: Before threading the puller screw into the stud, carefully check the cleanliness of both the stud's and the puller screw's conical threads. Apply a light coat of clean turbine oil or a spray lubricant to the puller screw. Do not use "Never Seize" on the conical threads. This procedure will ease assembly and assure positive mating of the threads before tightening.

Assembly sequence is as follows:

1. Open the hydraulic return valve on the pump to allow hydraulic fluid to be pushed back from the tensioner and into the pump reservoir. (This is automatic on the air-operated hydraulic pump)
2. Place the spanner ring on the nut. Insert the puller screw into the tapered thread of the stud and hand tighten. **Be sure not to cross-thread the puller screw.**
3. Using an Allen wrench, tighten the puller screw and then back off the puller screw 1/2 a turn. Retighten the puller screw by hand until it is fully inserted. **DO NOT BACK OFF THE PULLER SCREW.**



215 Clinton Road
New Hartford, NY 13413
Tel: +1 315 768 4855
Fax: +1 315 768 4941
Email: info@riverhawk.com

CUSTOMER'S INFORMATION BOX
CONTENTS ARE INDEPENDENT OF RIVERHAWK DOCUMENT CONTROL

GE DRAWING NUMBER	REV
100A1477	

4. Place the foot over the puller screw and orientate it into position.
5. Thread the tensioner onto the puller screw until it stops. Please note that the internal stop inside the tensioner will cause a gap in between the foot and tensioner. The gap should be 1/16" [1.6mm] to 3/16" [4.8mm]. **DO NOT ATTEMPT TO TIGHTEN THE TENSIONER AGAINST THE FOOT.**
6. Place the guard over the tensioner and position the guide pin into the hole in the backside of the stud.
7. Tighten the knurled interlock fitting by hand until it firmly presses against the tensioner. There should be no gap between the tensioner the interlock fitting.
8. Activate the custom connector from the rear of guard by pushing on the center with your thumb and pulling the tabs with your fore finger and middle finger. Push the assembly forward until it locks into the tensioner. Release fingers from the tabs and then remove thumb, ensure connection is firmly engaged or else the tensioner will not be connected to the pump.

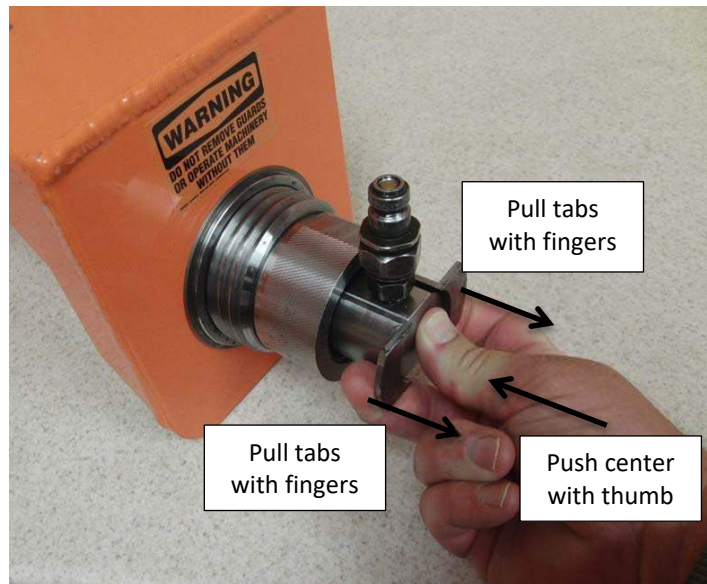

Picture 8E - Activation of the safety interlock

9. Connect the hydraulic pump to the tensioner. The tensioner should now be completely assembled and ready for use.



215 Clinton Road
New Hartford, NY 13413
Tel: +1 315 768 4855
Fax: +1 315 768 4941
Email: info@riverhawk.com

CUSTOMER'S INFORMATION BOX
CONTENTS ARE INDEPENDENT OF RIVERHAWK DOCUMENT CONTROL

GE DRAWING NUMBER	REV
100A1477	

8.3 Bleeding Hydraulic System

Bleeding of the hydraulic system is not necessary with this tensioner design.

9.0 Stud Tensioning

The studs will be tensioned in two steps, at 50% pressure and at final pressure. Follow the tensioning sequence for each flange joint as defined on the record sheets found at the end of this manual.

9.1 Tensioning at 50% pressure

After the tensioner is properly installed apply hydraulic pressure to the tool. Bring the pressure to the 50% level in accordance with the following table.

WARNING

The safety cage must be in place at all times. Keep hands out of designated areas at all times when the tensioner is pressurized otherwise personal injury can occur.

CAUTION

Before threading the puller screw into the stud, carefully check the cleanliness of both the stud's and the puller screw's conical threads. Apply a light coat of clean turbine oil or a spray lubricant to the puller screw. This procedure will ease assembly and assure positive mating of the threads before tightening. Do not use "Never Seize" on the conical threads.

CAUTION

Do not exceed the maximum pressure marked on the tensioner. Excessive pressure can damage the stud and puller screw.

CAUTION

Do not tighten the nut while the tool is coming up to pressure; wait until pressure is achieved before attempting to tighten the nut with the spanner ring. If the tool is not properly installed, the tool could jump off the stud while coming up to pressure.



215 Clinton Road
New Hartford, NY 13413
Tel: +1 315 768 4855
Fax: +1 315 768 4941
Email: info@riverhawk.com

CUSTOMER'S INFORMATION BOX
CONTENTS ARE INDEPENDENT OF RIVERHAWK DOCUMENT CONTROL

GE DRAWING NUMBER	REV
100A1477	

IM-455 Revision F
Page 24 of 41

<u>Flange Position</u>	<u>Stud Size</u>	<u>50% Pressure</u>	<u>50% Stretch</u>
A650 Stub Shaft to Generator	2-3/4" [71 mm]	11500 psi [800 bar]	Do not measure Do not use
A63 Steam Turbine to A63 Generator	2-3/4" [71 mm]	12000 psi [830 bar]	Do not measure Do not use

Firmly tighten the cylindrical nuts with approximately 20 ft·lbs [27 N·m] of torque using the pin wrench and spanner ring.

9.2 Removing the Tensioner from an Installed Stud

The tensioner removal is accomplished by the following steps:

1. Open the hydraulic return valve on the pump to allow hydraulic fluid to be pushed back from the tensioner and into the pump reservoir. (This is automatic on the air-operated hydraulic pump).
2. Unscrew the knurled interlock fitting at the end of the guard and remove the guard from the tensioner.
3. Unscrew the tensioner from puller screw.
4. Remove the foot from the puller screw.
5. Unscrew the puller screw using an Allen wrench. Tapping the Allen wrench with a hammer or the use of a 3-4' breaker bar may be necessary to loosen the puller screw. Do not use an impact wrench as this can damage the puller screw.
6. Remove the spanner ring from the nut.
7. Move the tool to the next bolt hole following the tensioning pattern from the stretched record sheets at the end of this manual.

9.3 Tensioning at Final Pressure

Repeat the pulling and tightening procedure stated above at full pressure. After all of the studs have been tensioned, measure the final stud length. The final pressure and required stretch values are listed in the following table.



215 Clinton Road
New Hartford, NY 13413
Tel: +1 315 768 4855
Fax: +1 315 768 4941
Email: info@riverhawk.com

CUSTOMER'S INFORMATION BOX
CONTENTS ARE INDEPENDENT OF RIVERHAWK DOCUMENT CONTROL

GE DRAWING NUMBER	REV
100A1477	

WARNING

The safety cage must be in place at all times. Keep hands out of designated areas at all times when the tensioner is pressurized otherwise personal injury can occur.

CAUTION

Before threading the puller screw into the stud, carefully check the cleanliness of both the stud's and the puller screw's conical threads. Apply a light coat of clean turbine oil or a spray lubricant to the puller screw. This procedure will ease assembly and assure positive mating of the threads before tightening. Do not use "Never Seize" on the conical threads.

CAUTION

Do not exceed the maximum pressure marked on the tensioner. Excessive pressure can damage the stud and puller screw.

CAUTION

Do not tighten the nut while the tool is coming up to pressure; wait until pressure is achieved before attempting to tighten the nut with the spanner ring. If the tool is not properly installed, the tool could jump off the stud while coming up to pressure.

<u>Flange Position</u>	<u>Stud Size</u>	<u>Final Pressure</u>	<u>Final Stretch</u>
A650 Stub Shaft to Generator	2-3/4" [71 mm]	23000 psi [1585 bar]	0.016" - 0.019" [0.41 mm - 0.48 mm]
A63 Steam Turbine to A63 Generator	2-3/4" [71 mm]	24000 psi [1655 bar]	0.014" – 0.017" [0.35 mm - 0.43 mm]

Firmly tighten the cylindrical nuts with approximately 20 ft·lbs [27 N·m] of torque using the pin wrench and spanner ring.

Failure to achieve the correct final stretch values may result in an incorrectly tensioned stud.

Incorrect stretch values can be corrected by uninstalling some or all of the selected studs. Re-measure the initial length of the studs and repeat the installation instructions studs. Excessive stretch variations can also be corrected by the same method.

Have final stretch values approved by the supervisor responsible for the installation.



215 Clinton Road
New Hartford, NY 13413
Tel: +1 315 768 4855
Fax: +1 315 768 4941
Email: info@riverhawk.com

CUSTOMER'S INFORMATION BOX
CONTENTS ARE INDEPENDENT OF RIVERHAWK DOCUMENT CONTROL

GE DRAWING NUMBER	REV
100A1477	

10.0 Nut Thread Locking and Windage Plug Installation

10.1 Nut Thread Locking



Picture 10A - Riverhawk Locknut

Mechanical lock nuts have two set screws located in the top face. Before threading the nut onto the stud, check to be certain the set screws are free to turn. Once the nut is seated torque the set screws to the values specified in the following table. When seated and torqued to the values specified, the load created by the set screw displaces the thread of the nut in the area of the web thereby creating the desired locking action.

<u>Stud Size</u>	<u>Set Screw Size</u>	<u>Torque</u>
2-3/4" [71 mm]	3/8"-24 UN	200 in·lbs - 250 in·lbs [22.6 N·m – 28.2 N·m]

10.2 Windage Plug Installation

Refer to the hardware assembly drawing (HF-xxxx) listed in Section 2.0 of this manual to determine if windage plugs are required for the installation. Along with other identifying markings, the windage plug's part number can be found on the plug's top surface as shown in the picture below.



215 Clinton Road
New Hartford, NY 13413
Tel: +1 315 768 4855
Fax: +1 315 768 4941
Email: info@riverhawk.com

CUSTOMER'S INFORMATION BOX
CONTENTS ARE INDEPENDENT OF RIVERHAWK DOCUMENT CONTROL

GE DRAWING NUMBER	REV
100A1477	

IM-455 Revision F
Page 27 of 41

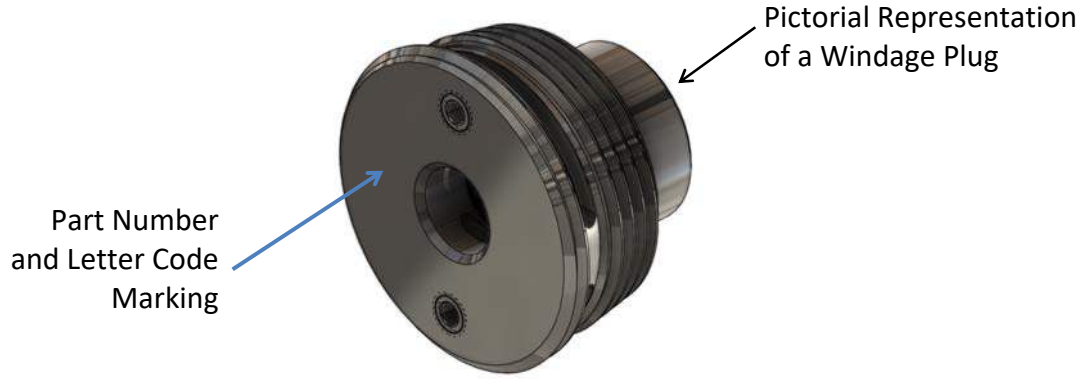

Picture 10B – Windage Plug’s Markings

To install the windage plug, use the following instructions:

1. Inspect the stud’s conical thread. It should have a bright and shiny appearance. The threads should be visually checked for any damage. Refer to Section 5.2 or Riverhawk Instruction Manual IM-220 (GE Vendoc 373A4025) for assistance.
2. Apply a light coat of clean turbine oil to the stud.

CAUTION

Before installation, carefully check the cleanliness of the windage plug’s and the stud's threads. Apply a light coat of clean turbine oil to the stud’s conical thread. This procedure will ease assembly before tightening. Do not use “Never Seize” on any surface or thread.



215 Clinton Road
New Hartford, NY 13413
Tel: +1 315 768 4855
Fax: +1 315 768 4941
Email: info@riverhawk.com

CUSTOMER'S INFORMATION BOX
CONTENTS ARE INDEPENDENT OF RIVERHAWK DOCUMENT CONTROL

GE DRAWING NUMBER	REV
100A1477	

- Thread the windage plug into the conical thread of the stud. The windage plug must not be cross-threaded when installed. Apply the following torque to seat the windage plug into the stud.

Windage Plug P/N	Installation Torque
7003292	350-450 in-lbs. [39.5-50.8 Nm]

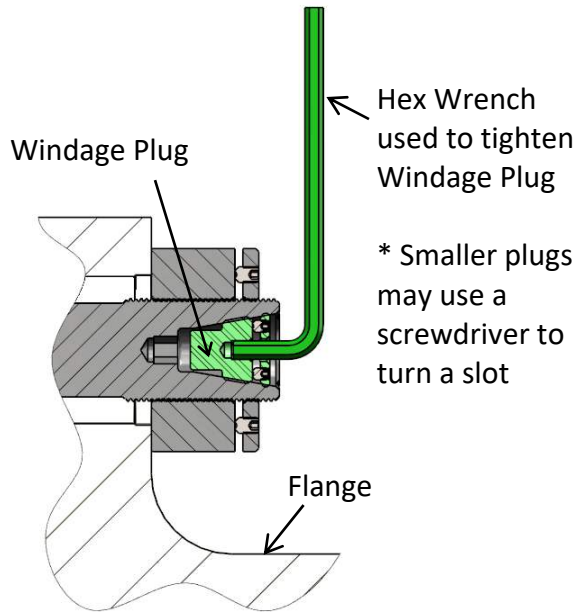

Figure 10C

- The windage plug includes a locking feature similar to the locking feature of the cylindrical nuts. The set screws must be torqued to the following amount. These set screws will cause the top section of the windage plug to lock onto the stud's threads.

Windage Plug P/N	Installation Torque
7003292	145-155 in-lbs. [16.4-17.5 Nm]

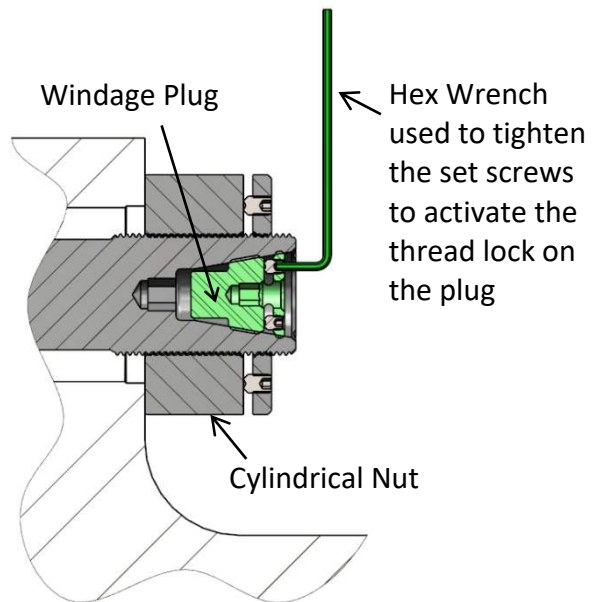

Figure 10D

WARNING

Do not use lock-tite on any of the threads and do not stake any component of this assembly.



215 Clinton Road
New Hartford, NY 13413
Tel: +1 315 768 4855
Fax: +1 315 768 4941
Email: info@riverhawk.com

CUSTOMER'S INFORMATION BOX
CONTENTS ARE INDEPENDENT OF RIVERHAWK DOCUMENT CONTROL

GE DRAWING NUMBER	REV
100A1477	

5. The windage plug should be at least 0.060" [1.5 mm] below the face of the stud for the locking feature to work correctly. If not, loosen set screws and reexamine the stud's and plug's threads for debris or damage. It may be necessary to replace the plug.
6. The set screws should flush to slightly below the top of the windage plug. The set screw should also press against the slot's opposite surface.

Wrong Installation Position



Partially Loose Set screw

Correct Installation Position

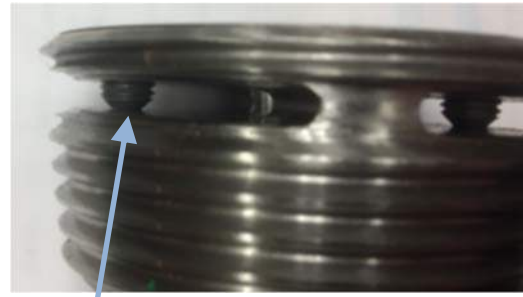

Pressed against Opposite Surface. No Gap.

Picture 10E – Set Screw Position

11.0 Stud and Nut Removal

11.1 Handling of the Tensioner

The tensioner used in this application is designed for no special lifting instructions. Do not drop any part of the tensioner on the operator or other nearby personnel.

11.2 Stud and Nut Removal

WARNING

The safety cage must be in place at all times. Keep hands out of designated areas at all times when the tensioner is pressurized otherwise personal injury can occur.

CAUTION

Before threading the puller screw into the stud, carefully check the cleanliness of both the stud's and the puller screw's conical threads. Apply a light coat of clean turbine oil or a spray lubricant to the puller screw. This procedure will ease assembly and assure positive mating of the threads before tightening. Do not use "Never Seize" on the conical threads.



215 Clinton Road
New Hartford, NY 13413
Tel: +1 315 768 4855
Fax: +1 315 768 4941
Email: info@riverhawk.com

CUSTOMER'S INFORMATION BOX
CONTENTS ARE INDEPENDENT OF RIVERHAWK DOCUMENT CONTROL

GE DRAWING NUMBER	REV
100A1477	

CAUTION

Do not exceed the maximum pressure marked on the tensioner. Excessive pressure can damage the stud and puller screw.

CAUTION

Do not tighten the nut while the tool is coming up to pressure; wait until pressure is achieved before attempting to tighten the nut with the spanner ring. If the tool is not properly installed, the tool could jump off the stud while coming up to pressure.

Refer to the hardware assembly drawing (HF-xxxx) listed in Section 2.0 of this manual and the tensioner assembly drawing (HT-xxxx) listed in Section 4.5 of this manual to determine how the tensioner must be assembled on the flange for its correct operation.

Section 8.0 contains diagrams of the tensioner equipment.

Note: Before threading the puller screw into the stud, carefully check the cleanliness of both the stud's and the puller screw's conical threads. Apply a light coat of clean turbine oil or a spray lubricant to the puller screw. Do not use "Never Seize" on the conical threads. This procedure will ease assembly and assure positive mating of the threads before tightening.

Disassembly sequence is as follows:

1. If present, remove the windage plugs from the studs by reversing the installation instructions from section 10.2. It may be necessary to use two Allen wrenches: one to stop the windage plug from rotating, one to remove the set screws. Do not misplace the set screws.
2. Using a wire brush (GT-4253) and shop air, clean the internal tapered thread of the stud to remove any debris/deposits which may have accumulated during service as described in section 5.2.2. Do not continue until ALL debris is removed from the threads.

WARNING

Do not use a hydraulic tensioner to remove a stud with damaged conical threads.

3. With an Allen-wrench loosen the two locking set screws but do not remove from the nut.



215 Clinton Road
New Hartford, NY 13413
Tel: +1 315 768 4855
Fax: +1 315 768 4941
Email: info@riverhawk.com

CUSTOMER'S INFORMATION BOX
CONTENTS ARE INDEPENDENT OF RIVERHAWK DOCUMENT CONTROL

GE DRAWING NUMBER	REV
100A1477	



Picture 11A - Loosening of a nut's set screws

4. Connect the hydraulic hose from the hydraulic pump to the tensioner.
5. Open the hydraulic return valve on the pump to allow hydraulic fluid to be pushed back from the tensioner and into the pump reservoir. (This is automatic on the air-operated hydraulic pump)
6. Place the spanner ring on the nut.
7. Insert the puller screw into the tapered thread of the stud and hand tighten. **Be sure not to cross-thread the puller screw.**
8. Using an Allen wrench, tighten the puller screw and then back off the puller screw 1/2 a turn. Retighten the puller screw by hand until it is fully inserted. **DO NOT BACK OFF THE PULLER SCREW.**
9. Place the foot over the puller screw and orientate it into position.
10. Thread the tensioner onto the puller screw until it stops. Please note that the internal stop inside the tensioner will cause a gap in between the foot and tensioner. The gap should be 1/16" [1.6mm] to 3/16" [4.8mm]. **DO NOT ATTEMPT TO TIGHTEN THE TENSIONER AGAINST THE FOOT.**
11. Place the guard over the tensioner and position the guide pin into the hole in the backside of the stud.



215 Clinton Road
New Hartford, NY 13413
Tel: +1 315 768 4855
Fax: +1 315 768 4941
Email: info@riverhawk.com

CUSTOMER'S INFORMATION BOX
CONTENTS ARE INDEPENDENT OF RIVERHAWK DOCUMENT CONTROL

GE DRAWING NUMBER	REV
100A1477	

IM-455 Revision F
Page 32 of 41

12. Tighten the knurled interlock fitting by hand until it firmly presses against the tensioner. There should be no gap between the tensioner the interlock fitting.
13. Activate the custom connector from the rear of guard by pushing on the center with your thumb and pulling the tabs with your fore finger and middle finger. Push the assembly forward until it locks into the tensioner. Release fingers from the tabs and then remove thumb, ensure connection is firmly engaged or else the tensioner will not be connected to the pump.

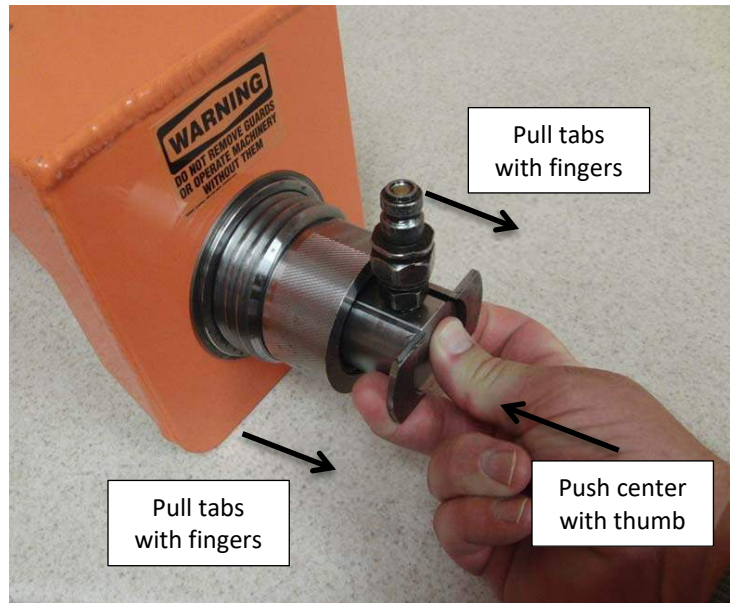

Picture 11B - Activation of the safety interlock

14. Connect the hydraulic pump to the tensioner and apply the appropriate hydraulic pressure per this table.

<u>Flange Position</u>	<u>Stud Size</u>	<u>Final Pressure</u>
A650 Stub Shaft to Generator	2-3/4" [71 mm]	23000 psi [1585 bar]
A63 Steam Turbine to A63 Generator	2-3/4" [71 mm]	24000 psi [1655 bar]

15. Turn the spanner ring with the pin wrench. Loosen and turn the nut approximately 3/4 of a turn.



215 Clinton Road
 New Hartford, NY 13413
 Tel: +1 315 768 4855
 Fax: +1 315 768 4941
 Email: info@riverhawk.com

CUSTOMER'S INFORMATION BOX
 CONTENTS ARE INDEPENDENT OF RIVERHAWK DOCUMENT CONTROL

GE DRAWING NUMBER	REV
100A1477	

16. Release the hydraulic pressure.

11.3.1 Removing the Tensioner from a Stud

The tensioner removal is accomplished by the following steps:

1. Open the hydraulic return valve on the pump to allow hydraulic fluid to be pushed back from the tensioner and into the pump reservoir. (This is automatic on the air-operated hydraulic pump).
2. Unscrew the knurled interlock fitting at the end of the guard and remove the guard from the tensioner.
3. Unscrew the tensioner from puller screw.
4. Remove the foot the puller screw.
5. Unscrew the puller screw using an Allen wrench. Tapping the Allen wrench with a hammer or the use of a 3-4' breaker bar may be necessary to loosen the puller screw. Do not use an impact wrench as this can damage the puller screw.
6. Remove the spanner ring from the nut.
7. Move the tool to the next bolt hole following the tensioning pattern from the stretched record sheets at the end of this manual.

12.0 Storage Instructions

Follow these directions to properly store your hydraulic tensioner and hydraulic pump kit for long term storage and shipment.

If any damage is observed, contact the Riverhawk Company to schedule a maintenance inspection.

12.1 Hydraulic Pump Kit Storage

Refer to the Hydraulic Pump Kit Instruction Manual, IM-293 (GE VENDOC 373A4058). The latest revision may be obtained by contacting Riverhawk Company or thru www.riverhawk.com.



215 Clinton Road
New Hartford, NY 13413
Tel: +1 315 768 4855
Fax: +1 315 768 4941
Email: info@riverhawk.com

CUSTOMER'S INFORMATION BOX
CONTENTS ARE INDEPENDENT OF RIVERHAWK DOCUMENT CONTROL

GE DRAWING NUMBER	REV
100A1477	

IM-455 Revision F
Page 34 of 41

12.2 Hydraulic Tensioner Storage

Check the tensioner for any damage.

1. Clean puller screw and check for any debris and dents.
2. Knurled interlock fitting should be clean and free to rotate.
3. Inspect the tensioner guard for any signs of damage. Bent guards must be replaced.

If any damage is observed, contact the Riverhawk Company to schedule a maintenance inspection.

Place the protective plastic cap on the guard's knurled interlock fitting.

Coat the hydraulic tensioner with a light coat of oil and place the tensioner into the original shipping container.

12.3 Store shipping container

Secure the hydraulic pump and hydraulic tensioner into the original shipping containers using the supplied wood braces.

Seal the original shipping container and store under shelter and protected from moisture, sand, and grit.

13.0 Frequently Asked Questions

This section contains some frequently asked questions and problems. If the steps listed here do not solve your problem, contact the Riverhawk Company thru our website, email, or phone call.

Q: Can I rent a hydraulic tensioner kit?

A: Yes, Riverhawk has rental tensioner kits available for most of our hydraulic tensioners.



215 Clinton Road
New Hartford, NY 13413
Tel: +1 315 768 4855
Fax: +1 315 768 4941
Email: info@riverhawk.com

CUSTOMER'S INFORMATION BOX
CONTENTS ARE INDEPENDENT OF RIVERHAWK DOCUMENT CONTROL

GE DRAWING NUMBER	REV
100A1477	

IM-455 Revision F
Page 35 of 41

Q: A tensioner has pulled itself out of the stud's conical threads. Can I continue using a tensioner on this stud?

A: No. Both the tensioner and the stud may have been damaged and must be removed from the work area. If the stud is tensioned, a Nut Buster repair kit, from Riverhawk, must be used to remove the damaged stud by drilling out the nut. Leaving a damaged stud in place will lead to a safety hazard on future outages.

Riverhawk can supply a replacement stud and nut based on the initial weight certification supplied with the hardware set (see section 4.2). The damaged tensioner should also be returned to Riverhawk for inspection and repair.

If a stud must be left in place, paint the damaged stud with a generous amount of indelible, bright-colored paint. Notify the appropriate GE Safety and Service personnel. Note the location of the damaged stud in the services notes for the machine.

Q: The hydraulic tensioner has been taken up to its final pressure. The final stretch length is short of the final stretch target. What is the next step?

A: Do not increase the hydraulic pressure. Check if the hydraulic pump is set to the right pressure. Install the tensioner and re-pressurize the tensioner to the final pressure then recheck the stretch measurement. If the stretch value is still short, remove the stud from the hole and re-measure the stud's initial length then try to install the stud again.

Q: The hydraulic tensioner has been taken up to its final pressure. The final stretch length is larger than the final stretch target. What is the next step?

A: Remove the stud from the bolt hole. Check if the hydraulic pump is set to the right pressure. Re-measure the stud's initial length then try to install the stud again.



215 Clinton Road
New Hartford, NY 13413
Tel: +1 315 768 4855
Fax: +1 315 768 4941
Email: info@riverhawk.com

CUSTOMER'S INFORMATION BOX
CONTENTS ARE INDEPENDENT OF RIVERHAWK DOCUMENT CONTROL

GE DRAWING NUMBER	REV
100A1477	

- Q:** The tensioner is at its final pressure, but the nut cannot be loosened.
- A:** If the nuts cannot be loosened at the final pressure, continually increasing the pressure will not help and can be dangerous and in some cases make it harder to remove the nut. Check the nut to see if its set screws have been loosened. Check for and remove any corrosion around the nut's threads. Apply penetrating oil between the stud and the nut.
- Q:** How do I clean the conical threads on a stud?
- A:** The conical threads are best cleaned using a spiral wound brass brush in a drill as described in section 5.2.2
- Q:** During the initial steps of removing a tensioned stud, the stick-out length is found to be wrong.
- A:** Do not proceed. Contact Riverhawk for assistance. With the wrong stick-out length, the hydraulic tensioner has a limited stroke and may not work properly and can be damaged.
- Q:** The hydraulic pump appears to be leaking.
- A:** Check the hose connection to the hydraulic pump. If the 3/8" high pressure fitting is not assembled correctly as shown in section 7.2, it may look like the pump is leaking. If the problem continues, it may be necessary to open the pump kit. Contact Riverhawk for guidance.
- Q:** The hydraulic hose has a collar on it that can't be moved by hand
- A:** The hydraulic fitting is shown in section 7.2. The collar is sometimes held in place with a thread locking compound. This prevents the collar from moving too easily. It may be necessary to adjust this collar with a set of vise-grip pliers. Be careful to not strip the threads off the tube or hose end.



215 Clinton Road
New Hartford, NY 13413
Tel: +1 315 768 4855
Fax: +1 315 768 4941
Email: info@riverhawk.com

CUSTOMER'S INFORMATION BOX
CONTENTS ARE INDEPENDENT OF RIVERHAWK DOCUMENT CONTROL

GE DRAWING NUMBER	REV
100A1477	

14.0 Revision History

Revision Letter	Effective Date	Description
F	Aug 1, 2024	Added HT-9769 to section 2 and 4.5
E	Dec 5, 2023	Revised air pressure required for AP-6048 pumps from 80psi [5.5 bar] to 90psi [6.2 bar] in section 3
D	Jun 20, 2023	HT-9788 replaces HT-8903 in section 2 and 4.5
C	Nov 29, 2022	Added 305T5129 to the title page and section 2.2; Inserted figures 8C and 8D; Added A63 steam turbine to tables in sections 9.1, 9.3 and 11.2
B	Apr 4, 2022	Updated EC Declaration of Conformity; Added UKCA Declaration of Conformity
A	Aug 25, 2020	134T5165 was 134T5156 in section 2.1
-	Nov 7, 2019	Released



215 Clinton Road
 New Hartford, NY 13413
 Tel: +1 315 768 4855
 Fax: +1 315 768 4941
 Email: info@riverhawk.com

CUSTOMER'S INFORMATION BOX
 CONTENTS ARE INDEPENDENT OF RIVERHAWK DOCUMENT CONTROL

GE DRAWING NUMBER	REV
100A1477	

Appendix A1

EC Declaration of Conformity

Manufacturer: Riverhawk Company
Address: 215 Clinton Road
New Hartford, NY 13413, USA

The hydraulic pump and bolt tensioning tool described in this manual are used for installing and applying tension to large bolts that are specifically designed by Riverhawk Company to be tensioned hydraulically.

All applicable sections of European Directive 2006/42/EC for machinery have been applied and fulfilled in the design and manufacture of the hydraulic pump and bolt tensioning tool described in this manual. Reference also ISO 12100:2010, ISO 4413:2010, and ISO 4414:2010.

Furthermore, this equipment has been manufactured under the Riverhawk quality system per EN ISO 9001:2015

Consult the Declaration of Conformance included with the shipment of this equipment that identifies the authorized Riverhawk representative, applicable serial numbers, and appropriate signature.



215 Clinton Road
New Hartford, NY 13413
Tel: +1 315 768 4855
Fax: +1 315 768 4941
Email: info@riverhawk.com

CUSTOMER'S INFORMATION BOX
CONTENTS ARE INDEPENDENT OF RIVERHAWK DOCUMENT CONTROL

GE DRAWING NUMBER	REV
100A1477	

Appendix A2

UKCA Declaration of Conformity

Manufacturer: Riverhawk Company
Address: 215 Clinton Road
New Hartford, NY 13413, USA

The hydraulic pump and bolt tensioning tool described in this manual are used for installing and applying tension to large bolts that are specifically designed by Riverhawk Company to be tensioned hydraulically.

All applicable sections of Supply of Machinery (Safety) 2008 have been applied and fulfilled in the design and manufacture of the hydraulic pump and bolt tensioning tool described in this manual. Reference also ISO 12100:2010, ISO 4413:2010, and ISO 4414:2010.

Furthermore, this equipment has been manufactured under the Riverhawk quality system per EN ISO 9001:2015

Consult the Declaration of Conformance included with the shipment of this equipment that identifies the authorized Riverhawk representative, applicable serial numbers, and appropriate signature.



215 Clinton Road
New Hartford, NY 13413
Tel: +1 315 768 4855
Fax: +1 315 768 4941
Email: info@riverhawk.com

CUSTOMER'S INFORMATION BOX
CONTENTS ARE INDEPENDENT OF RIVERHAWK DOCUMENT CONTROL

GE DRAWING NUMBER	REV
100A1477	

Appendix B1

STRETCH RECORD SHEET FOR
THE STEAM TURBINE TO GENERATOR

TURBINE NUMBER:

DATE:

TECHNICIAN:

SUPERVISOR:

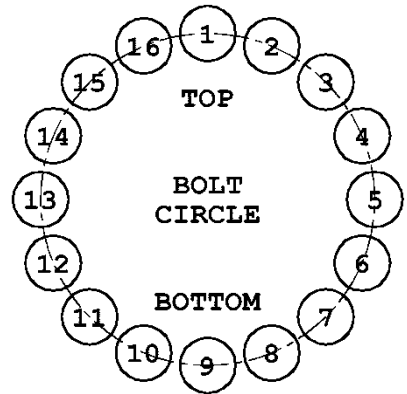

HOLE NUMBER	STARTING MEASUREMENT	FINAL MEASUREMENT	FINAL GAUGE READING
1			
9			
5			
13			
15			
7			
3			
11			
8			
16			
12			
4			
10			
2			
6			
14			

CUSTOMER'S INFORMATION BOX

CONTENTS ARE INDEPENDENT OF RIVERHAWK DOCUMENT CONTROL

GE DRAWING NUMBER	REV
100A1477	



215 Clinton Road
New Hartford, NY 13413
Tel: +1 315 768 4855
Fax: +1 315 768 4941
Email: info@riverhawk.com