

INSTRUCTION MANUAL
IM-334
For
HTC/ COUPLING ASSEMBLY
HC-6483

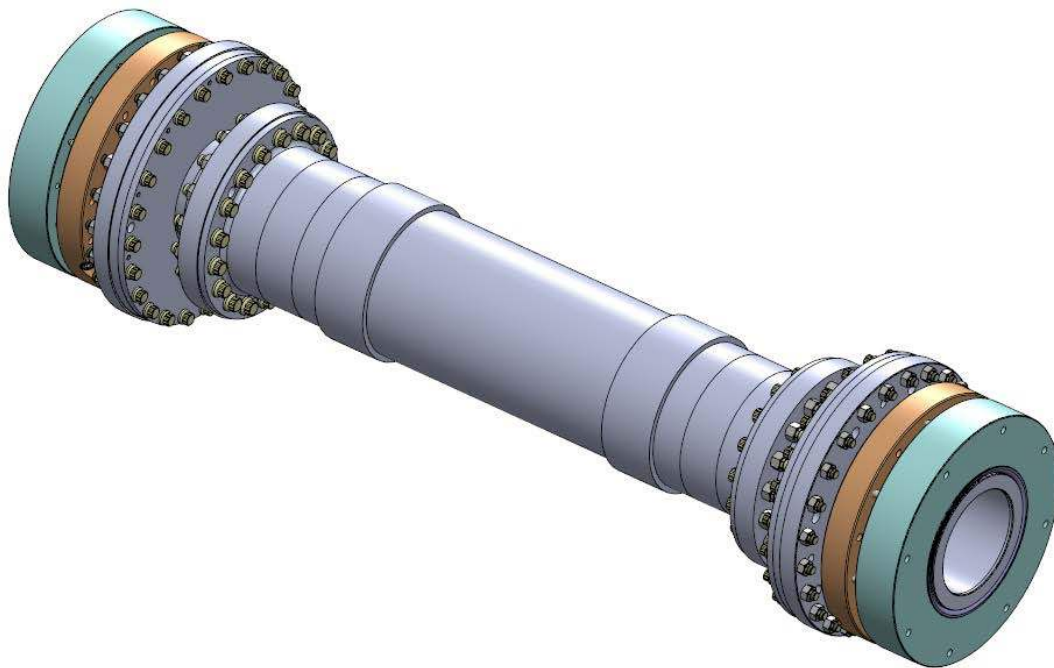

The Riverhawk Company reserves the right to make changes updating this document without dissemination or notice. The latest revision level may be obtained by contacting The Riverhawk Company directly. Visit www.riverhawk.com for additional information.



215 Clinton Road
New Hartford, New York 13413
Voice: 315-768-4855 Fax: 315-768-4855

Instruction Manual IM-334
For
HC-6483

Contents:

<u>Section</u>	<u>Description</u>	<u>Page</u>
1.	General Description	3
1.1.	Warnings and Cautions	5
1.2.	Tools and Hardware Required	5
1.3.	Support Documents	6
1.4.	Technical Support	6
1.5.	General Installation Procedures	7
1.6.	General Removal Procedures	7
1.7.	Match-Marking	7
2.	Machinery Alignment	8
3.	HTC/ Hub Assembly Installation	9
4.	Flex Assembly and Center Spacer Installation	14
5.	Center Spacer and Flex Assembly Removal	18
6.	HTC/ Hub Assembly Removal	22
7.	Maintenance and Inspection	25



215 Clinton Road
New Hartford, New York 13413
Voice: 315-768-4855 Fax: 315-768-4855

Instruction Manual IM-334

For HC-6483

1. General Description

This unit consists of a Riverhawk flexible coupling with a Riverhawk Hydraulic Torque Coupler and hub on each end to interface with the customer shaft.

The Riverhawk flexible coupling consists of a center spacer tube bolted to a flex assembly at each end. It also includes all of the applicable hardware.

The Hydraulic Torque Coupler (HTC) connects the hub to the shaft. It accomplishes this by squeezing the hub OD with very high pressure. This pressure forces the hub to squeeze down onto the shaft producing a tight fit. Squeeze is produced when hydraulic pressure is applied. This separates the piston and cylinder of the HTC. As these rings separate, they ride up the slopes of the collet generating interference. Figure 1a shows the hub mounted on the shaft using an HTC. Prior to assembly, the hub and shaft have been machined to produce a keyless, cylindrical slip fit.

A tool kit is also supplied with the coupling with components used during installation or removal of the hub/HTC from the shaft ends, as shown in Figure 1b.

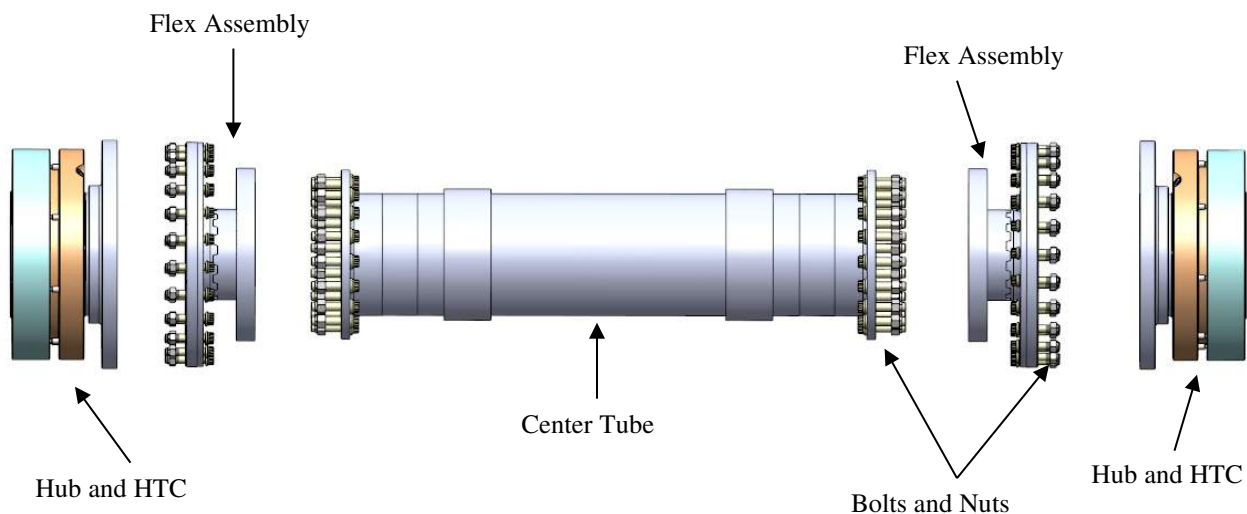

Figure 1 – Components

Instruction Manual IM-334
For
HC-6483

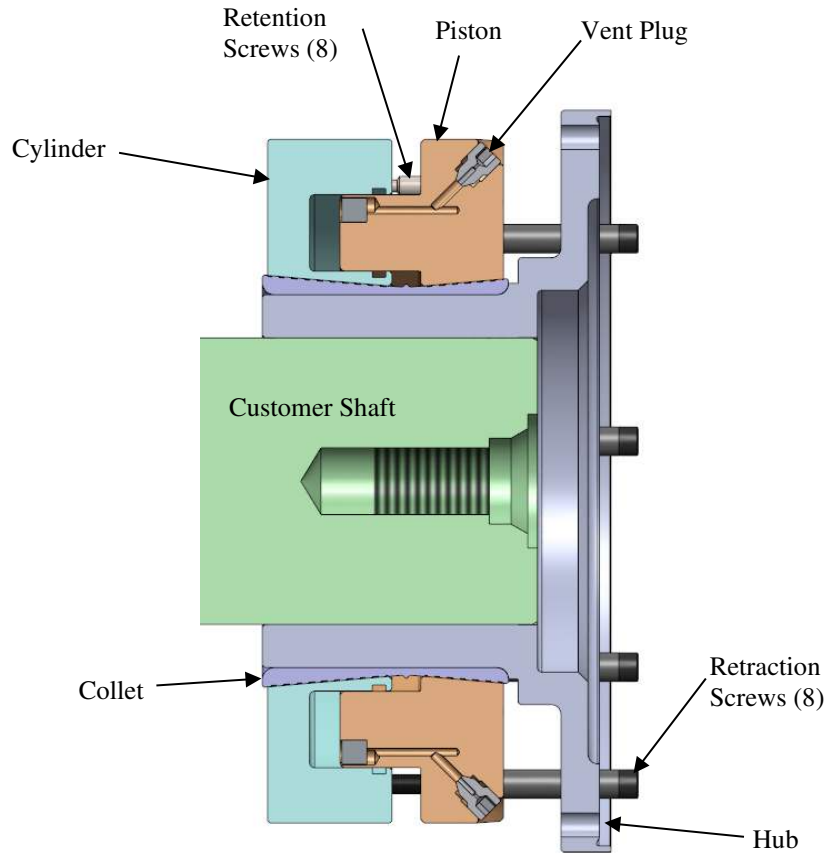

Figure 1a – HTC/ Hub Assembly Cross-Section

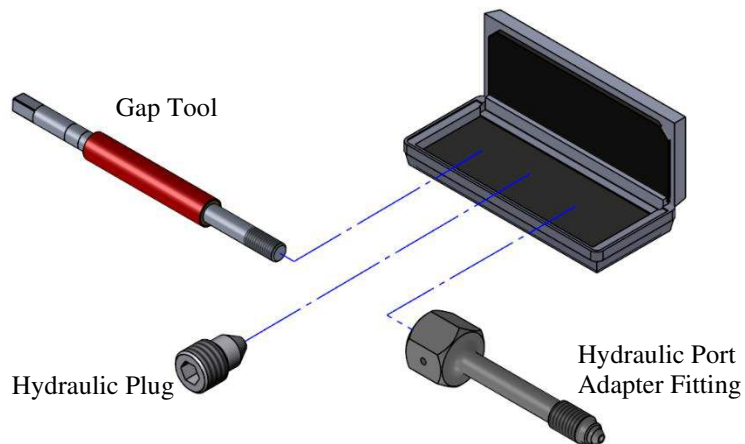

Figure 1b – Tool Kit

Instruction Manual IM-334 For HC-6483

1.1 Warnings and Cautions

Below is a list of warnings and cautions. Be sure to heed the warnings and cautions as they apply to each step of assembly and disassembly.

Caution: Possible equipment damage. Do not put excessive torque on the hydraulic port adapter. Do not pull on hydraulic port adapter (See Figure 5).

Warning: Crush hazard, Keep fingers and objects out of the HTC gap when releasing pressure.

Caution: DO NOT exceed the "MAX GAP" listed on drawing HC-6483. This is a limit value.

Caution: Watch three things while applying hydraulic pressure.

- First: watch the gap. Stop pumping if it exceeds the "MAX GAP" stated on the drawing.
- Second: Do Not apply more than 8,000 psi.
- Third: retract all screws completely. Make sure that all set screws are fully retracted before releasing the pressure during removal.

Caution: Do not dent or scratch the outside surfaces of the thin flexible diaphragms that are exposed when being installed. If damage is seen on this surface, contact Riverhawk before use.

1.2 Tools and Hardware Required

The following are tools required to install, operate, and remove HC-6483.

<u>Part Number</u>	<u>Description</u>	<u>Installation</u>	<u>Removal</u>
MP-2349	Hydraulic pump and hose kit capable of 10,000 psi. (Riverhawk supplies pumps designed to simplify HTC operation)	X	X
-	Set of inch hex keys	X	X
-	Dial Caliper (or Gap Tool Below)	X	
-	Oil Drain Pan	X	X
-	Set of Inch Combination Wrenches	X	X
-	Torque Wrench	X	
GT-5872*	Installation and Removal Tool Kit includes:		
	7500784 Gap Tool, HTC	X	
	2001992 3/8-24 Hydraulic Port Adapter Fitting	X	X
	2001299 3/8-24 Hydraulic Plug	X	X

* Supplied with HC-6483 coupling



215 Clinton Road
New Hartford, New York 13413
Voice: 315-768-4855 Fax: 315-768-4855

Instruction Manual IM-334
For
HC-6483

1.3 Support Documents

Please obtain and read carefully the latest revision of the following documents before proceeding with installation.

<u>Document Number</u>	<u>Title</u>	<u>Source</u>
IM-334	Instruction Manual for HC-6483	Riverhawk Company
HC-6483	HTC/Flex Coupling Assembly Drawing	Riverhawk Company

1.4 Technical Support

Technical support can be found by contacting:

Riverhawk Company
215 Clinton Road
New Hartford, NY 13413

Phone: (315) 768-4855
Fax: (315) 768-4941
E-mail: service@riverhawk.com



215 Clinton Road
New Hartford, New York 13413
Voice: 315-768-4855 Fax: 315-768-4855

Instruction Manual IM-334

For

HC-6483

1.5 General Installation Procedure

Below is a very abbreviated summary on the installation of the HC-6483 components. Also noted is the section of this manual in which you will find more detailed descriptions and diagrams. Be sure to read these instructions completely before proceeding with installation.

- 1) Align machinery and determine required hub position on shaft (See Section 2.)
- 2) Install both HTC/Hub assemblies onto the shafts (see Section 3.)
- 3) Install both flex assemblies onto the hubs (see Section 4.1)
- 4) Install the center spacer tube (see Section 4.2)

1.6 General Removal Procedure

Below is a very abbreviated summary on the removal of the HC-6483 components. Also noted is the section of this manual in which you will find more detailed descriptions and diagrams. Be sure to read these instructions completely before proceeding with removal.

- 1) Remove the center spacer tube (see Section 5.1)
- 2) Remove both flex assemblies from the hubs (see Section 5.2)
- 3) Remove both HTC/Hub assemblies from the shafts (see Section 6.)

1.7 Match-Marking

The five main rotating assemblies included in HC-6483 (drive-end hub/clamp assembly, drive-end flex assembly, center spacer tube, load-end flex assembly, and load-end hub/clamp assembly) have been individually dynamically balanced. To ensure balance is maintained, components in these assemblies must remain clocked properly. Match-marks have been scribed on components in these assemblies to be used to ensure alignment is proper. Match mark alignment is described in sections below.

Since the entire unit has not been balanced together, the five main assemblies can be bolted to each other clocked in any position (with the exception of the center tube). Therefore **MATCH MARKS ON ONE MAIN ASSEMBLY DO NOT NEED TO BE ALIGNED WITH MATCH MARKS ON THE OTHER TWO MAIN ASSEMBLIES**. For example, match mark on the flex assembly flange OD does not need to be aligned with match marks on the hub flange OD.

The center tube has match-marks at both ends that must be aligned with match marks of the flex assemblies in order to provide access to jacking taps during the removal process.

Dis-assembly of the three main rotating assemblies is not needed, and should not be done unless authorized by Riverhawk, or by Riverhawk-trained personnel.



215 Clinton Road
New Hartford, New York 13413
Voice: 315-768-4855 Fax: 315-768-4855

Instruction Manual IM-334

For HC-6483

2. Machinery Alignment

Machinery should be aligned per the equipment manufacturer's instructions, ensuring the coupling will be operated within the rated misalignments shown on drawing HC-6483. The coupling is designed to operate at the normal torque while subjected to full axial and angular misalignment ratings stated on the drawing. Note that to minimize reaction loads on machinery bearings, it is best to keep misalignment as low as possible, regardless of coupling capability.

Proper placement of the hubs on the shaft end depends on the actual length of the coupling center tube, coupling flex assemblies, actual recess depth of the hubs, actual distance between shaft ends, and required installed axial pre-stretch. With the shafts properly positioned after alignment (against thrust bearings for example), measure and record distance between shaft ends. The center tube has the actual length scribed on the OD ("L = xx.xxx"). The flex assemblies have the actual lengths scribed on the OD. The hubs have the actual depth of the recess from the flange face scribed in the recess. Using the actual distances, the required hub overhang from the shaft ends can be found:

- BSE = ACTUAL DISTANCE BETWEEN SHAFT ENDS
- D1 = ACTUAL DRIVE HUB FLANGE RECESS DEPTH (NOMINAL = 0.807")
- D2 = ACTUAL LOAD HUB FLANGE RECESS DEPTH (NOMINAL = 0.807")
- LF1 = ACTUAL DRIVE-END FLEX ASSEMBLY LENGTH (NOMINAL = 2.825")
- LF2 = ACTUAL LOAD-END FLEX ASSEMBLY LENGTH (NOMINAL = 2.825")
- LT = ACTUAL CENTER TUBE LENGTH (NOMINAL = 22.736")
- PRE = REQUIRED PRE-STRETCH

$$\text{REQUIRED HUB OVERHANG FROM SHAFT END} = (\text{BSE} - \text{D1} - \text{D2} - \text{LF1} - \text{LF2} - \text{LT} - \text{PRE}) / 2$$

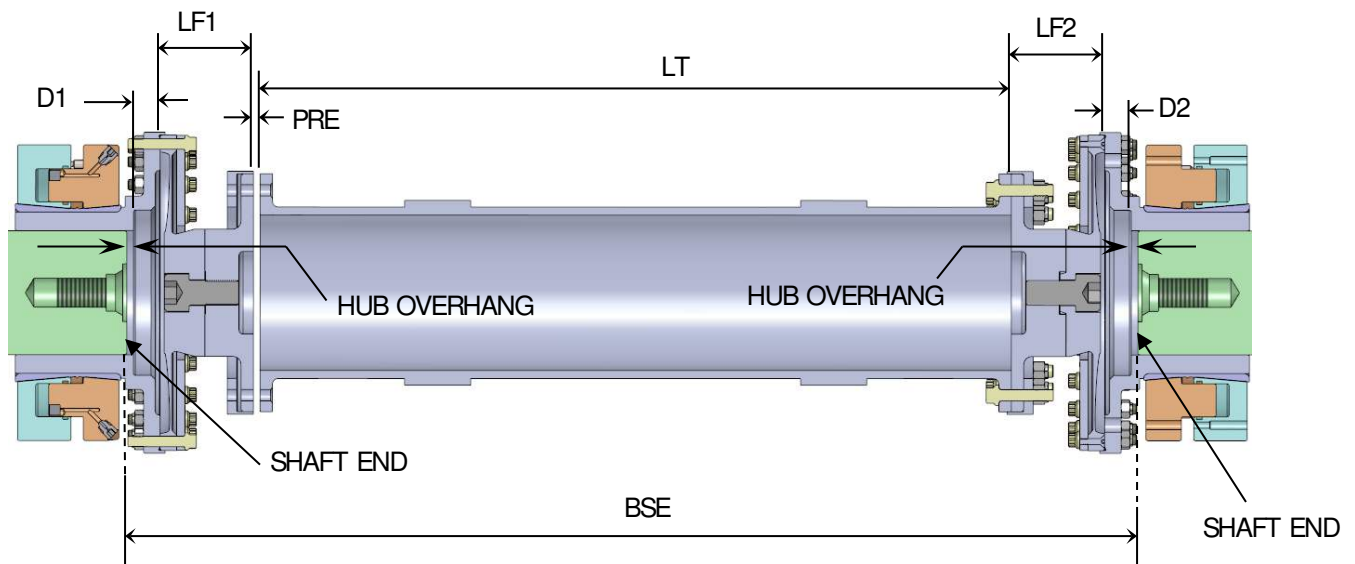

Figure 2 – Hub Overhang Calculation

Note that during installation, one end of the center tube will be the last joint bolted together. The distance between the mating flange faces of this joint will equal the actual prestretch achieved. This gap should be measured during installation to verify proper prestretch.

Instruction Manual IM-334

For HC-6483

3. HTC/ Hub Assembly Installation

This section describes how to install the HTC onto the hub and then the HTC/hub assembly onto the shaft.

3.1 Hub and Shaft Inspection

Inspect the hub and shaft to assure that they have been machined to the proper tolerances. The HTC should slide onto the hub with a sliding or light press fit. The hub should fit the shaft in the same manner. Remove any burrs or proud metal that could interfere using a white India Stone.

3.2 Cleaning

The hub OD, ID and the shaft OD must be smooth and free of debris. Clean using a solvent that leaves no residue such as acetone. Cleaning of these surfaces is especially important because contamination can make the surfaces slippery and cause the surfaces to slip prematurely during operation. Take special care to remove any thick oils or waxes using a solvent.

3.3 Mount HTC on Hub.

Usually you will receive the HTC and Hub already assembled together. If the HTC and hub are already assembled go to Section 3.3.3. If they are not together, assemble them as follows. Note the HTC and Hub have been factory balanced as an assembly. Each is marked with a part number similar to 7500995-X where X is the serial number. The serial number on the hub must match the serial number on the HTC in order to ensure proper balance.

3.3.1 Remove the vent plugs (see Figure 1a). Tighten the retraction screws to 10-15 ft-lbs. Be sure the gap is closed (see Figure 3a).

3.3.2 Put the hub face down on a table. Align the match marks on the collet, Hub, and HTC to as shown in Figure 3a to ensure proper balance. Slide the HTC onto it until stop as shown in Figure 3b. Be sure to slide the HTC onto the hub evenly as there may be a slight interference fit. Always push on the COLLET, not on any other component of the HTC when sliding the HTC on hub.

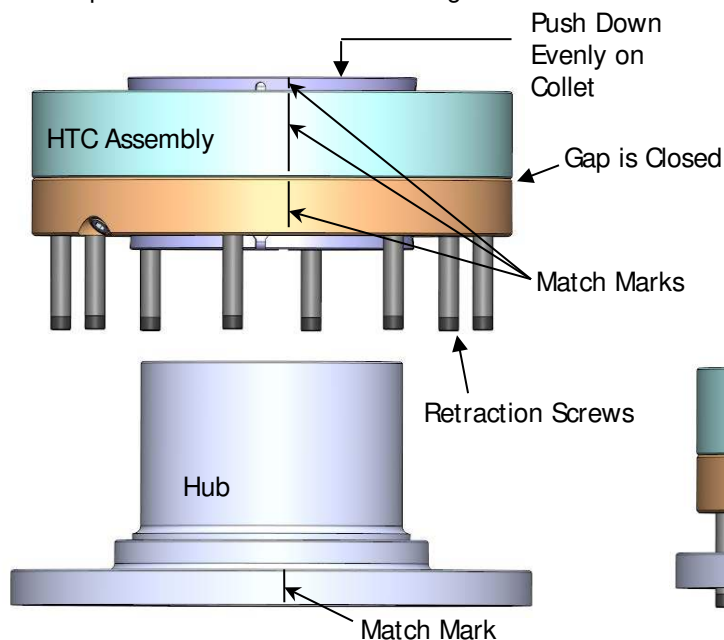

Figure 3a

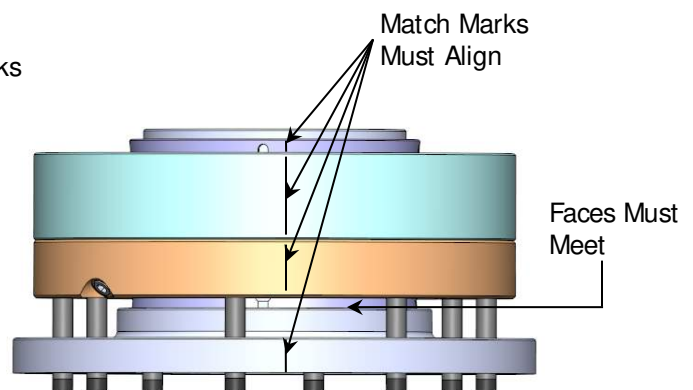

Figure 3b



215 Clinton Road
New Hartford, New York 13413
Voice: 315-768-4855 Fax: 315-768-4855

Instruction Manual IM-334
For
HC-6483

3.3.3 Remove the retraction screws.

3.3.4 Verify that the match marks are properly aligned as in Figure 3b.

3.3.5 If the HTC is loose on the hub, lightly hand tighten the socket head set screws (retention screws) just until the HTC will no longer rotate on the hub. This will allow you to handle the assembly without the match marks becoming misaligned. Note - if you over tighten these screws the assembly will not fit onto the shaft.

3.3.6 Again verify the match marks are aligned as in Figure 3b.

3.4 Mounting the HTC/ Hub Assembly on the shaft

3.4.1 Gently slide the hub onto the shaft until the face of the shaft is flush with the face of the flange.

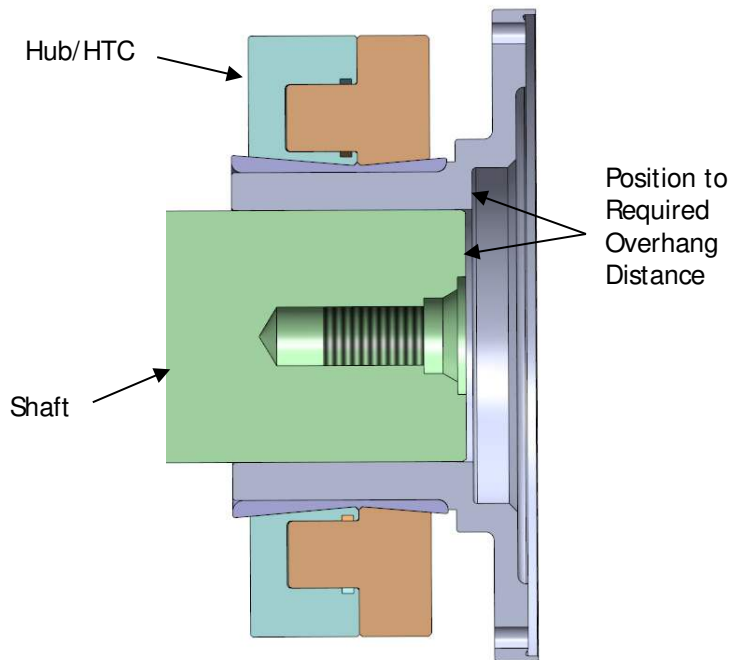

Figure 4 - Shaft Assembly Cross-section

3.4.2 Verify all (8) retraction screws have been fully removed.

3.4.3 Turn the HTC/Hub assembly so that the hydraulic ports are at the 12 and 6 o'clock positions. This will facilitate draining of the oil in latter steps. Remove vent plugs from both ports if not already done.

3.4.4 Thread the Hydraulic Port Adapter fitting (Riverhawk PN 2001992) into one of the hydraulic ports on the HTC as shown in Figure 5. The fitting can be used in either port.

Instruction Manual IM-334
For
HC-6483

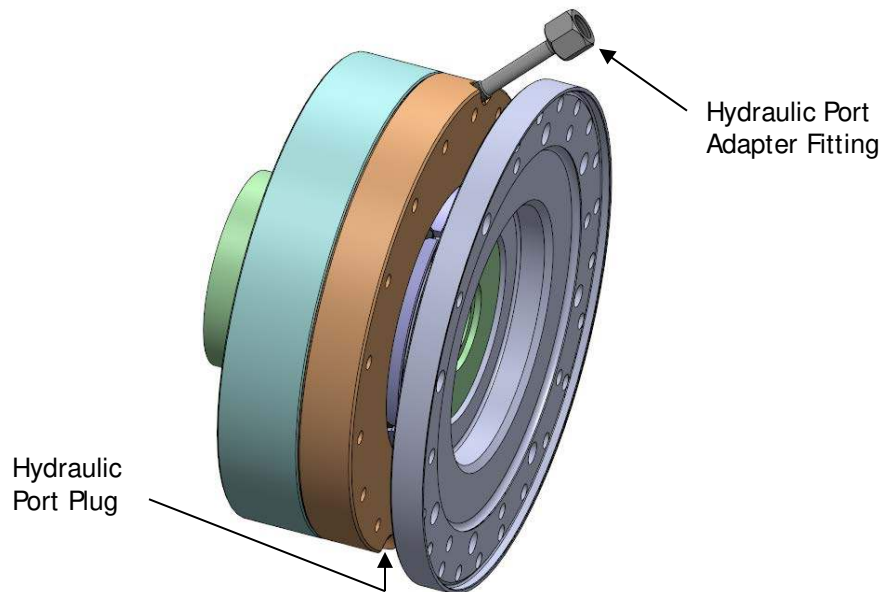

Figure 5 – Port Fittings

3.4.5 Thread a Hydraulic Plug 2001299 into the other hydraulic port located 180° from the Port Adapter Fitting.

3.4.6 Attach Riverhawk pump kit MP-4910, or MP-2349, or equivalent to the Port Adapter Fitting.

3.4.7 Slowly apply hydraulic pressure and stop the pump when the hub will no longer turn on the shaft by hand. This is known as the "first grip" position and is important for correctly setting the HTC. Note and record the pump pressure setting at this first grip position.

3.4.8 Release the pump pressure to allow the hub to move freely on the shaft end again.

3.4.9 Re-position the hub on the shaft end in the correct position (hub recess face overhang from the shaft end) for proper alignment as described in Section 2.0.

3.4.10 Slowly pump to apply hydraulic pressure and stop when the first grip pressure setting last noted is achieved. Maintain this position by holding the hydraulic pressure for the next step.

3.4.11 The proper setting of the HTC is accomplished by the separation or gap between the two halves of the clamp (see Figure 1a). A special Gap Tool (Riverhawk PN 7500784) has been provided to facilitate this setting. Be sure you maintain the First Grip Position from the previous step until the tool is in place. Thread the gap tool into one of the retraction screw holes until the outer sleeve aligns with the first scribe line on the rod (see Figure 6a). The tool is spring loaded so you will need to push and turn in order to start the thread.



215 Clinton Road
New Hartford, New York 13413
Voice: 315-768-4855 Fax: 315-768-4855

Instruction Manual IM-334

For HC-6483

Align Outer Sleeve with First
Scribed Line on Rod for Initial Grip

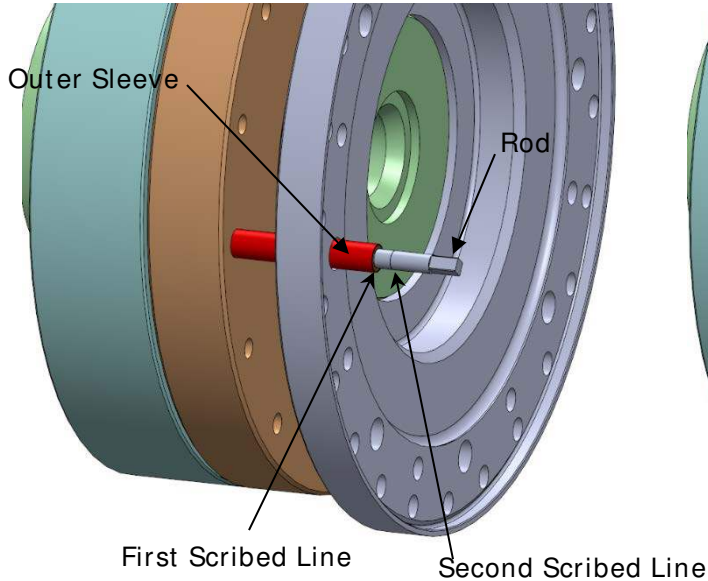

Figure 6a - Setting Initial Grip Position

Align Outer Sleeve with Second
Scribed Line on Rod for Final Position

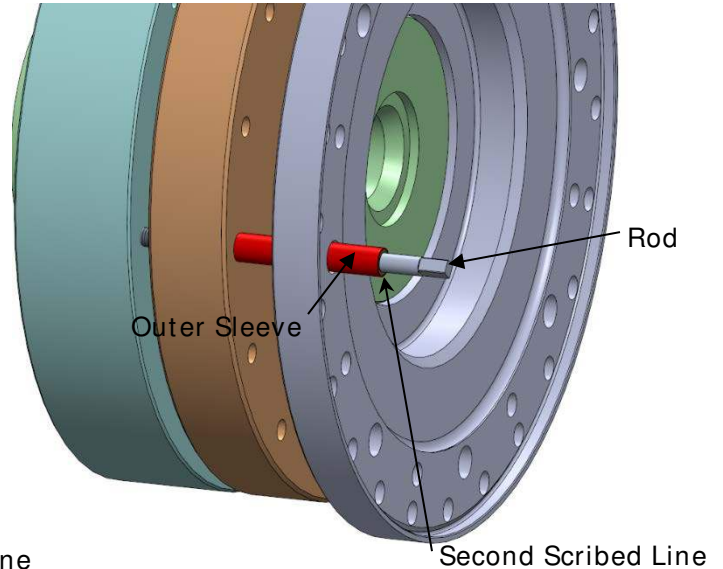

Figure 6b - Setting Final Position

3.4.12 Apply more hydraulic pressure. The HTC halves will separate causing the outer sleeve of the tool to move towards the second scribe line on the rod. When the outer sleeve is aligned with the second scribe line as shown in figure 6b, stop the hydraulic pump while holding pressure. This is the final position of the clamp. Hold hydraulic pressure here for the next step.

Note: The Gap Tool is supplied so that proper gap on the HTC can be set through the hub flange. In the event that the gap tool is unavailable, the actual gap can be measured with gage pins or a caliper. Measure the Gap for the "First Grip Position" in step 3.4.7 above. Add 0.249 inches to that measurement to calculate the Total Required Gap. Apply hydraulic pressure while monitoring the gap until the measurement is equal to the Total Required Gap.

Instruction Manual IM-334
For
HC-6483

3.4.13 Tighten the eight retention screws (socket head set screws) hand tight with a hex wrench. The screws are accessed through the flange face as shown in Figure 7.

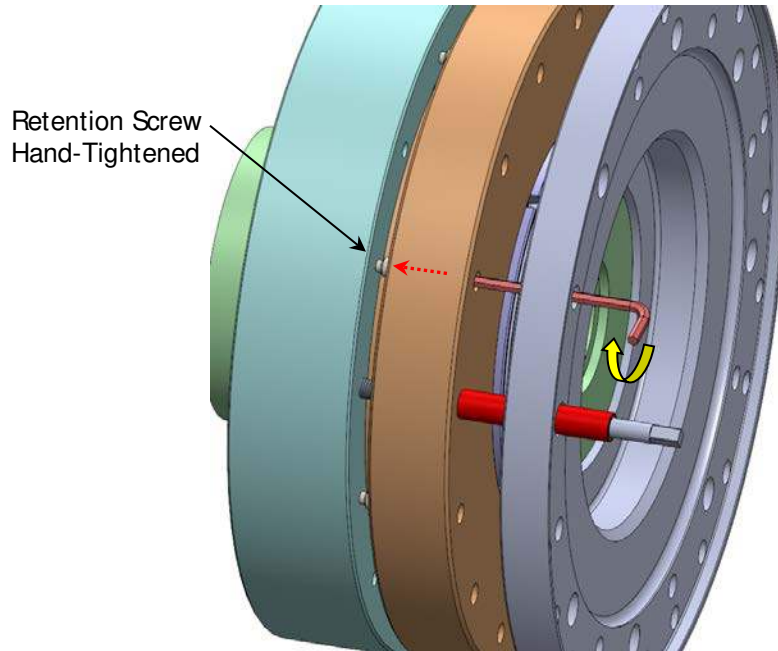

Figure 7 – Tightening Retention Screws

3.4.14 Release the hydraulic pressure from the pump.

3.4.15 Remove the gap setting tool.

3.4.16 Place a drain pan under the HTC and remove the hydraulic plug and then the adapter fitting. Allow hydraulic oil to drain from the HTC. Blow compressed air (100 psi max) into the top port to fully drain the oil. Failure use compressed air to blow out oil will leave residual oil in the clamp and may cause problems with the balance of the unit.

3.4.17 The retraction screws, hydraulic plugs, adapter fitting, and gap tool will be required for future removal and installation of the clamp. Store them where they will not be lost.

3.4.18 Place vent plugs 2002429 in both hydraulic ports after all oil is drained (see Figure 1a).

Instruction Manual IM-334
For
HC-6483

4. Coupling Flex Assembly and Center Spacer Tube Installation

This section contains the installation procedure for the two flex assemblies and the center spacer tube between the two hubs. Prior to installation, verify that the hubs are located in the proper position on the shaft ends based on actual lengths and actual distance between shaft ends (see Section 2.).

4.1 Flex Assembly Installation

4.1.1 Install one flex assembly onto the hub as shown in Figure 8 aligning the holes using Qty (4) bolts and nuts spaced 90 degrees apart. Tighten the bolts/nuts a few turns at a time in a criss-cross pattern to seat the pilot evenly. Install the remaining bolts and nuts and torque evenly in a criss-cross pattern to the torque shown on drawing HC-6483.

4.1.2 Repeat for the opposite shaft.

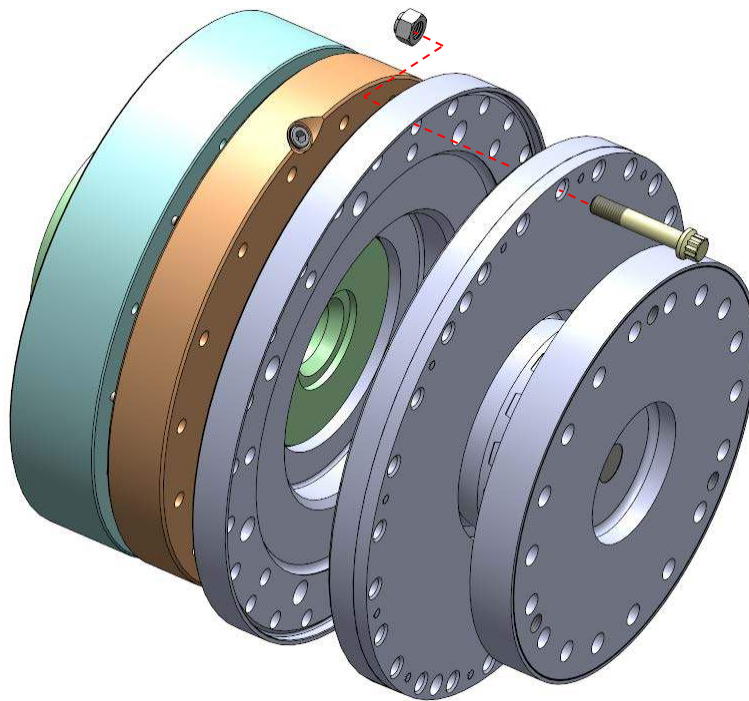

Figure 8 – Flex Assembly Installation on Hub Flange

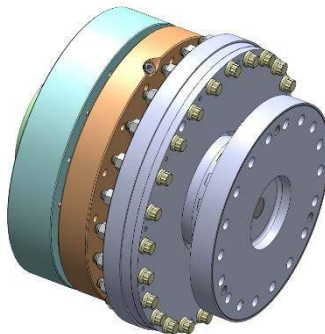

Figure 9 – Flex Assembly Installed



215 Clinton Road
New Hartford, New York 13413
Voice: 315-768-4855 Fax: 315-768-4855

Instruction Manual IM-334
For
HC-6483

4.2 Center Spacer Tube Installation

The center spacer tube fits between flanged ends of the flex assemblies. Verify that the piloting rings at the flanged ends of the flex assemblies are retracted (see Figure 12). Follow instructions in Section 5.1.2 if the rings need to be retracted.

4.2.1 Slide the center tube between the flex assemblies as shown in Figure 10.

4.2.2 Rotate the tube to line-up match-mark on the flange OD with the match-marks on the flex assembly OD, and align the holes using Qty (4) bolts spaced 90 degrees apart, as shown in Figure 11. The match-marks must be aligned to ensure access to the jacking holes used during removal.

4.2.3 While supporting the weight of the tube, tighten the bolts/nuts a few turns at a time in a criss-cross pattern to draw the piloting ring over the tube flange evenly (see Figure 13). Install the remaining bolts and nuts and torque evenly in a criss-cross pattern to the torque shown on drawing HC-6483.

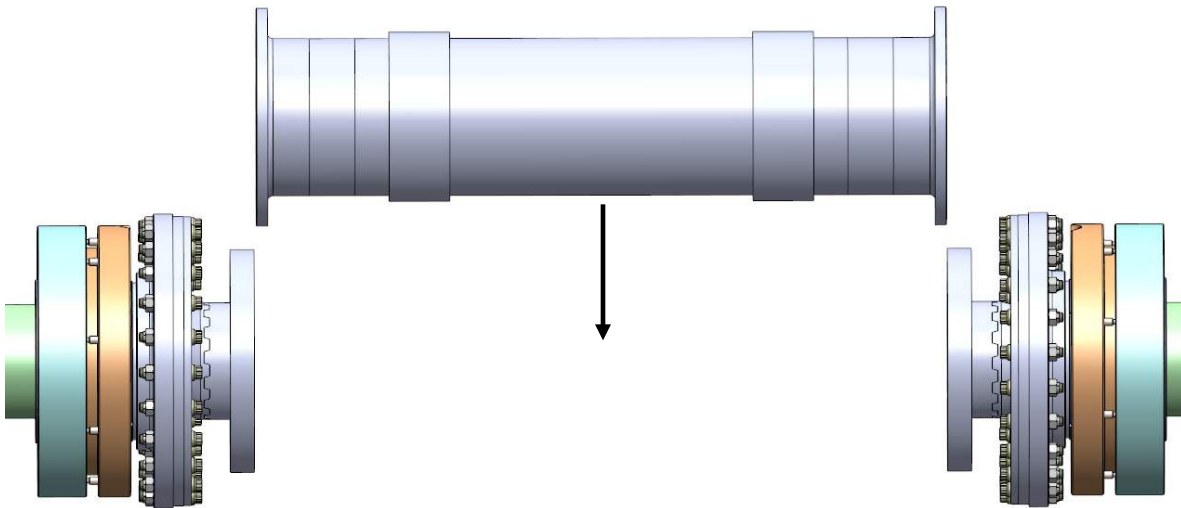

Figure 10 – Slide Center Spacer Tube Between Flex Assemblies

Instruction Manual IM-334
For
HC-6483

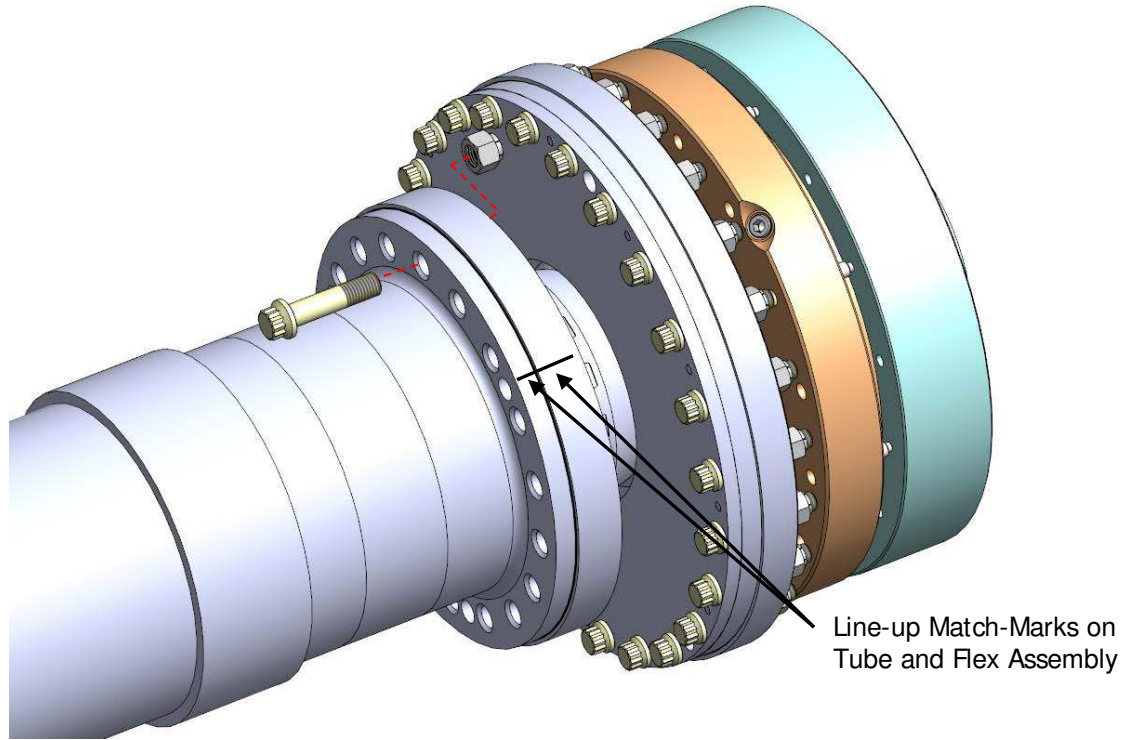

Figure 11 – Align Tube to Flex Assembly

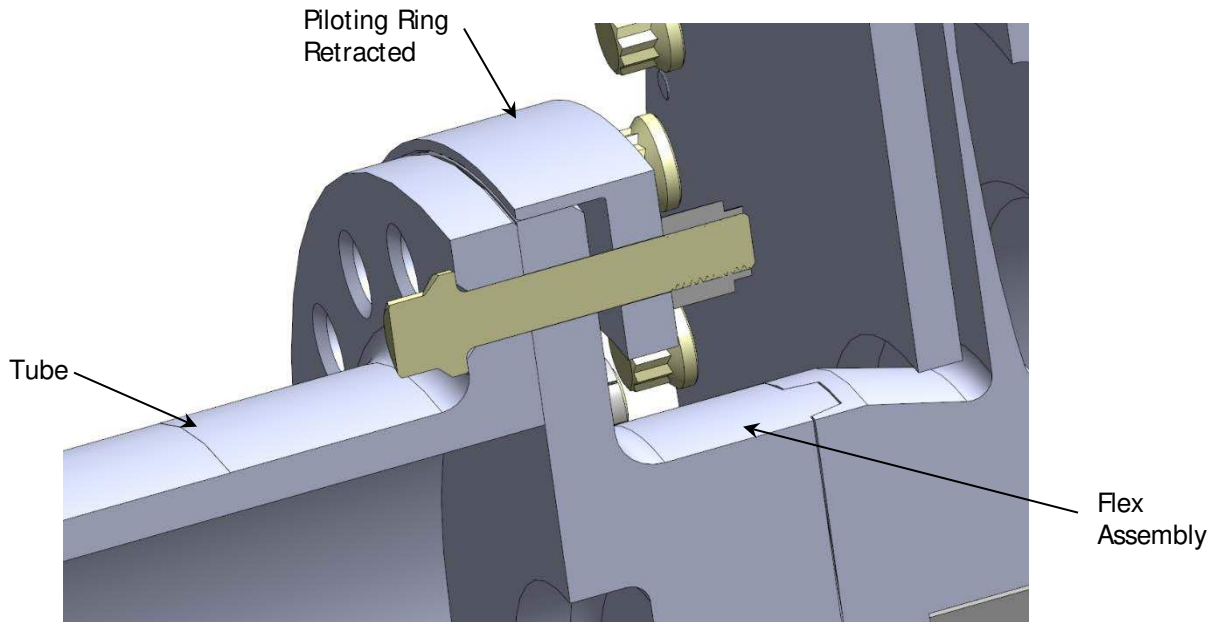

Figure 12 – Bolt Tube to Flex Assembly

Instruction Manual IM-334

For
HC-6483

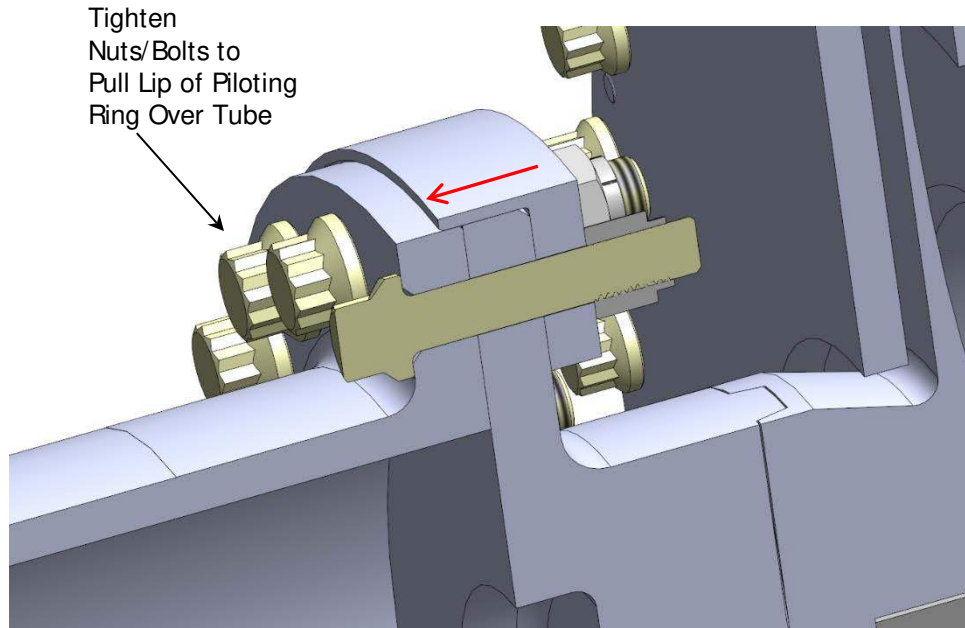

Figure 13 – Piloting Ring Fit Over Tube OD

4.2.4 Rotate the equipment as required to line-up the match-mark on the opposite end of the tube with the match-mark on the mating flex assembly.

4.2.5 Measure the gap between the flange faces. This gap distance is the actual prestretch that the coupling will have when installed (see Figure 14). Verify the prestretch is as required.

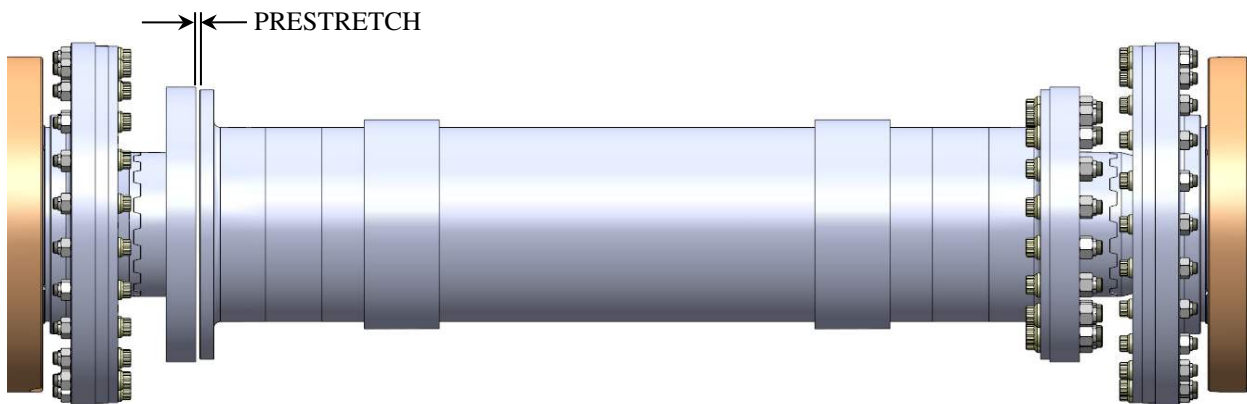

Figure 14 – Prestretch Gap Check at Final Bolted Joint

4.2.6 Bolt the tube to the flex assembly using same procedure as the first end.



Instruction Manual IM-334

For HC-6483

5. Center Spacer Tube and Flex Assembly Removal

This section describes the removal procedure for the center spacer tube and the flex assemblies.

5.1 Center Spacer Tube Removal

5.1.1 While supporting the tube weight, remove all bolts and nuts at one flanged end of the center tube. Store the removed bolts together, and the removed nuts together as they are supplied in weight-matched sets.

5.1.2 Insert (3) of the removed 3/8-24 bolts in the jacking taps of the joint as shown in Figure 15. Turn the bolts in an even criss-cross pattern to retract the piloting ring away from the tube (see Figure 16). When the lip of the piloting ring is just past the mating faces, such that the tube can be removed, stop retracting and remove the bolts from the jacking taps.

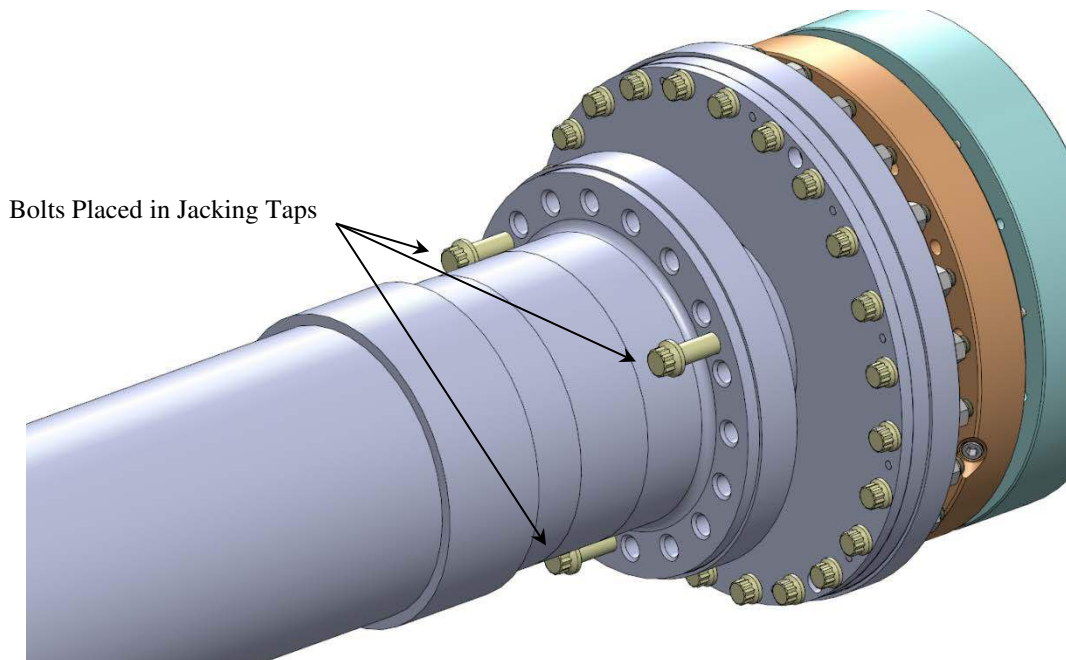

Figure 15 – Bolts in Jacking Taps for Tube Removal

Instruction Manual IM-334
For
HC-6483

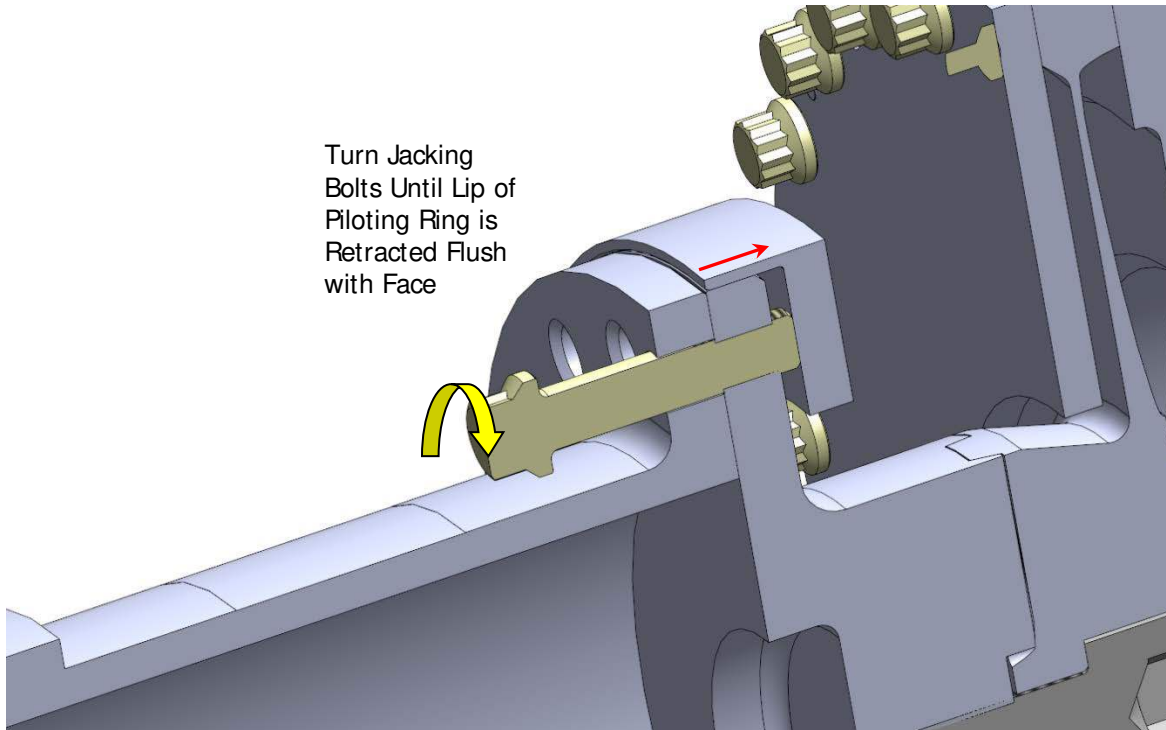

Figure 16 – Retraction of Piloting Ring

5.1.3 Repeat removal of the hardware and retraction of the piloting ring at the other end of the tube.

5.1.4 Slide the tube out as shown in Figure 17.

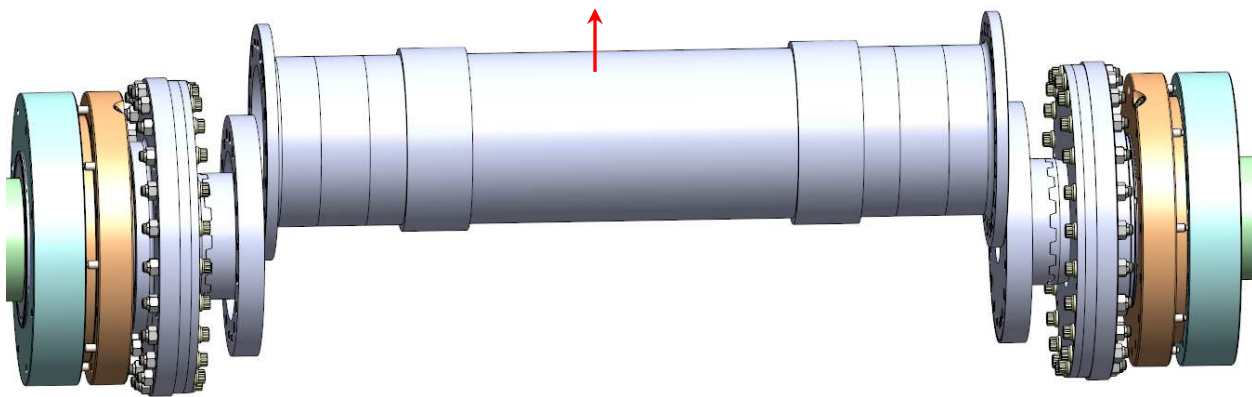

Figure 17 – Center Tube Removal



215 Clinton Road
New Hartford, New York 13413
Voice: 315-768-4855 Fax: 315-768-4855

Instruction Manual IM-334
For
HC-6483

5.2 Flex Assembly Removal

5.2.1 Remove all nuts and bolts attaching the flex assembly to the hub. Store the removed bolts together, and the removed nuts together as they are supplied in weight-matched sets.

5.2.2 Insert (3) of the removed 5/16-24 bolts in the jacking taps of the joint as shown in Figure 18.

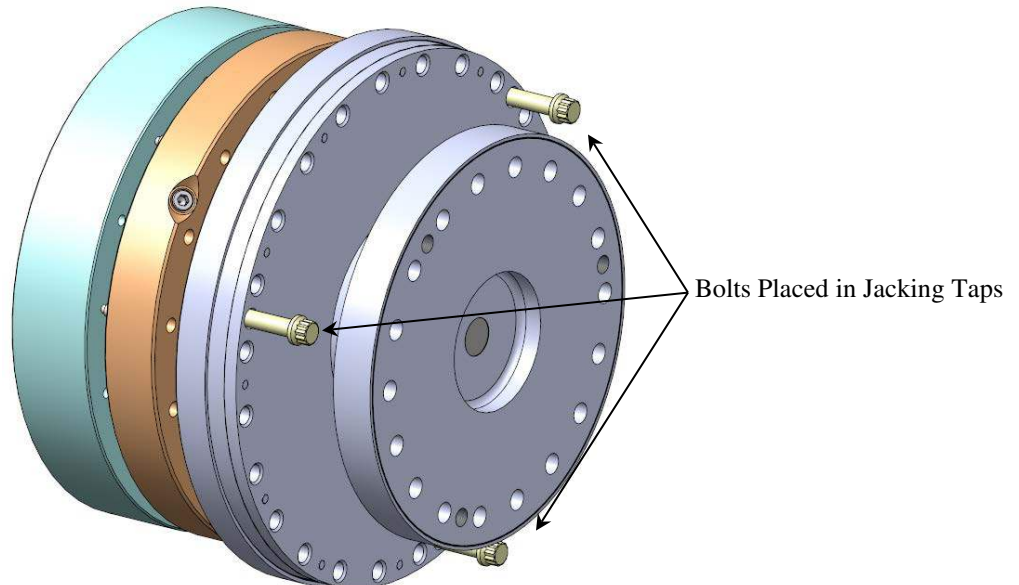

Figure 18 – Bolts in Jacking Taps for Flex Assembly Removal

5.2.3 While supporting the flex assembly weight, turn the jacking bolts in an even criss-cross pattern to disengage the assembly from the hub, as shown in Figure 19. Remove the jacking bolts from the taps.

5.2.4 Repeat for the flex assembly at the opposite hub.

Instruction Manual IM-334
For
HC-6483

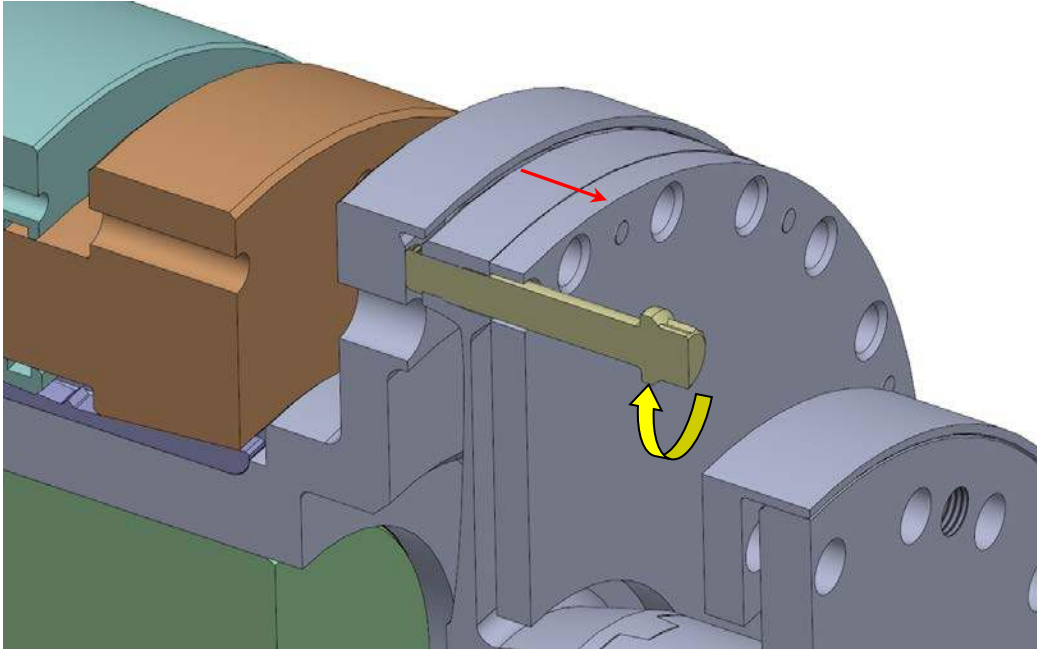

Figure 19 – Use of Jacking Bolts Disengage Pilot Fit

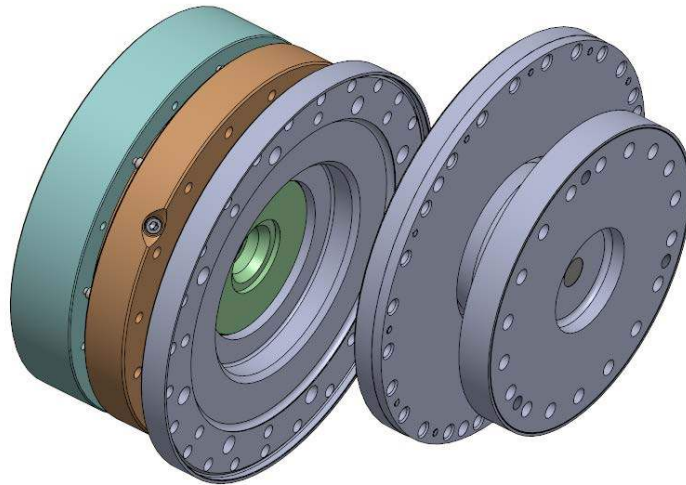

Figure 20 – Flex Assembly Removed



215 Clinton Road
New Hartford, New York 13413
Voice: 315-768-4855 Fax: 315-768-4855

Instruction Manual IM-334
For
HC-6483

6. Removal of HTC/ Hub Assembly

This section explains how to remove the HTC/Hub assemblies from the shafts.

6.1 Remove vent plugs from both hydraulic ports.

6.2 Install the hydraulic adapter in one port as in Figure 5.

6.3 Install one hydraulic plug in the opposite port on the HTC.

6.4 Connect the hydraulic pump and slowly apply pressure while attempting to loosen one of the retention set screws by hand with a hex wrench. The retention set screws are accessed thru the face of the flange as shown in Figure 21. As soon as the screw is free to rotate stop the pump and hold the pressure.

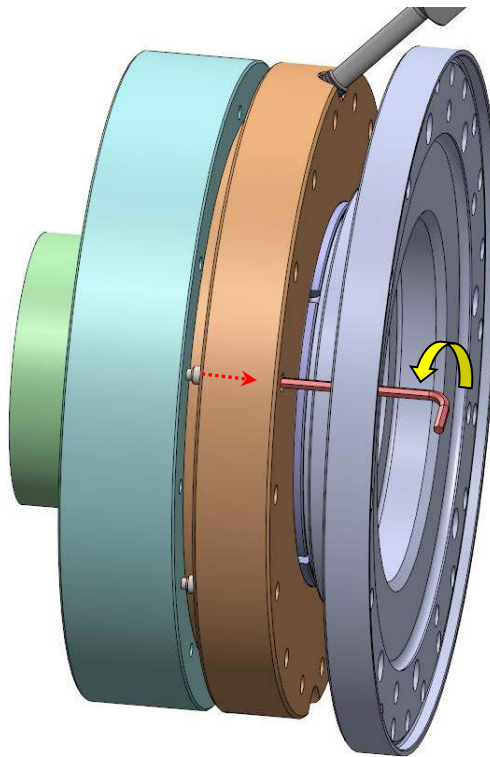

Figure 21 – Loosen Retention Screws While Pressure is Applied

Caution - Over stroking the HTC will cause damage to it. Stop increasing pressure the moment the retention screws are free to turn. Do not, under any circumstances, exceed 8,000 psi hydraulic pressure. Normal pressure required ranges from 4,000 - 6,000 psi.

6.5 Remove all of the retaining screws (8). Save retaining screws for future use. Do not mix with retaining screws from other units. Screws are weight matched in sets of (8) for proper balance.

6.6 Release the hydraulic pressure. Allow 20 seconds or more for the clamp to close and oil to drain back into the pump. The HTC/Hub assembly should now be loose on the shaft.

Warning: Crush hazard, Keep fingers and objects out of the gap when releasing pressure.



215 Clinton Road
New Hartford, New York 13413
Voice: 315-768-4855 Fax: 315-768-4855

Instruction Manual IM-334
For
HC-6483

Caution: Watch while pumping.

- Do Not apply more than 8,000 psi.
- Make sure that all set screws are fully retracted before releasing the pressure.

6.7 If the hub does not slide easily on the shaft, the HTC may not be fully closed. Make sure the retention screws are completely loosened. Install the (8) retraction screws (see Figure 22). Tighten the retraction screws to 10 ft-lbs. The retraction screws will draw the clamp closed and loosen the hub on the shaft.

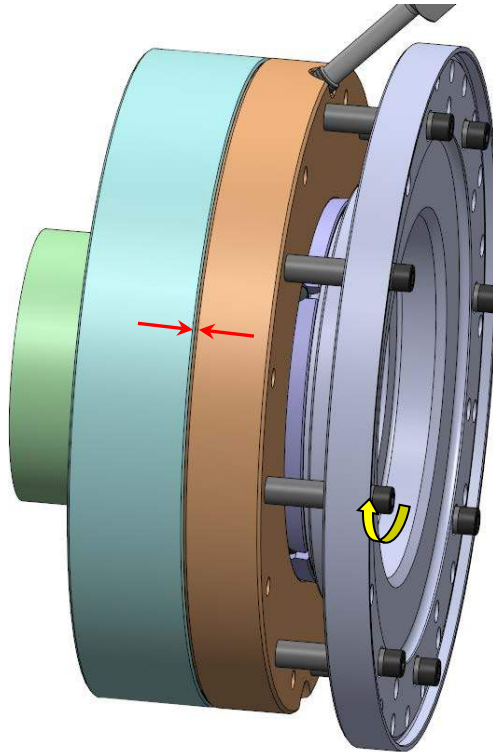

Figure 22 – Using Retraction Screws to Collapse HTC

6.8 You may partially activate the clamp for the purpose of lifting the hub/HTC assembly without the hub sliding off. Remove the retraction screws. Re-install and tighten the retention screws evenly using only hand torque. This will partially open the gap and cause the HTC to grip only the hub, not the shaft, so it won't slide off the hub during lifting and handling.

6.9 Remove hydraulic connections, plug, and adapter fitting. Catch any residual hydraulic fluid with a drain pan or rag. Add vent plugs back into both hydraulic ports.

6.10 Carefully slide the hub assembly off the shaft.



215 Clinton Road
New Hartford, New York 13413
Voice: 315-768-4855 Fax: 315-768-4855

Instruction Manual IM-334
For
HC-6483

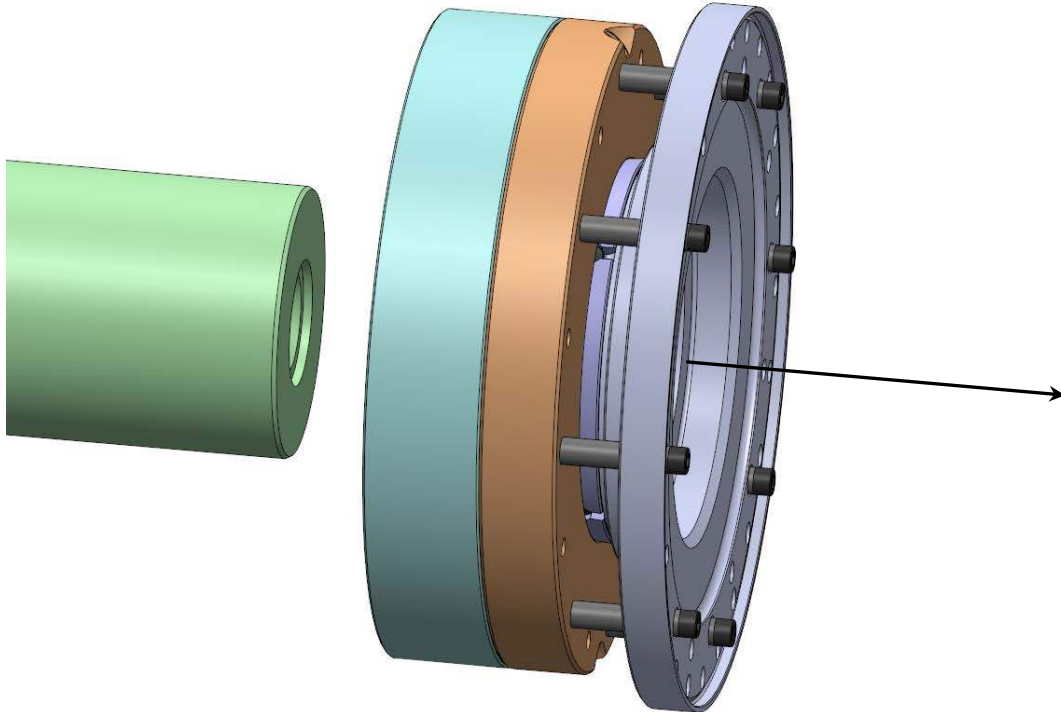

Figure 23 – Hub/ HTC Assembly Removed from Shaft

6.11 Repeat the procedure above for the other shaft end.

Instruction Manual IM-334
For
HC-6483

7. Maintenance and Inspection

Coupling assembly HC-6483 is designed to operate over the life of the machinery. Special shutdowns for maintenance of HC-6483 alone are not required. Routine inspection during time of equipment overhaul will be sufficient for normal operating conditions.

7.1 Center Flex Unit Maintenance

7.1.1 Check bolts and nuts connecting the center flex unit to the drive and load hubs for tightness.

7.1.2 The self-locking feature of the nuts attaching the center flex unit to the drive and load-end hubs will degrade after repeated installation/removal cycles. Replace the locknuts after about 20 cycles.

7.1.3 Grip the center tube and attempt to move it in all directions. If excessive looseness or noise is heard, it may indicate damage to the flexible elements. Removal of the center flex unit for further inspection would be required in this case.

7.1.4 If time is available, complete an alignment check between machines to ensure the assembly is operating within its capability. Check of installed axial pre-stretch can be completed by unbolting one end of the center tube (while supporting its weight), retracting the piloting ring, and measuring the gap, as described in section 4.



215 Clinton Road
New Hartford, New York 13413
Voice: 315-768-4855 Fax: 315-768-4855