



INSTRUCTION MANUAL IM-293
**For Hydraulic Pump Kits used with Gas and
 Steam Turbine's Hydraulic Tensioners**

Applicable Riverhawk Part Numbers

- MP-0130 Manual Hydraulic Pump Kit
- MP-6809 Manual Hydraulic Pump Kit
- AP-0532 Air-Driven Hydraulic Pump Kit
- AP-6048 Air-Driven Hydraulic Pump Kit
- AP-10478 Air-Driven Hydraulic Pump Kit

Applicable GE Ordering Sheet Part Numbers

- No Specific Ordering
- Sheet Part Numbers

CUSTOMER'S INFORMATION BOX

CONTENTS ARE INDEPENDENT OF RIVERHAWK DOCUMENT CONTROL

GE Power & Water		GENERAL ELECTRIC COMPANY	
<u>VENDOR SUPPLIED</u>			
GE NOT TO REVISE. GE REVISION LEVEL IS SHOWN ON THIS APPLIQUE. THIS DOCUMENT IS FILED UNDER THE GE DRAWING NUMBER.			
THIS DOCUMENT SHALL BE REVISED IN ITS ENTIRETY. ALL SHEETS OF THIS DOCUMENT ARE THE SAME REVISION LEVEL AS INDICATED IN THIS VENDOR SUPPLIED DRAWING APPLIQUE.			
MLI:		_____ OF _____	
GE SIGNATURES	DATE	GE DRAWING NUMBER	REV
CHECKED:		373A4058	
ISSUED:			

The Riverhawk Company reserves the right to update this document without dissemination or notice. The latest revision may be obtained by contacting Riverhawk Company or thru www.riverhawk.com.



Repairs – Rentals
 Field Service

215 Clinton Road
 New Hartford, NY 13413
 Tel: +1 315 768 4855
 Fax: +1 315 768 4941
 Email: info@riverhawk.com

Table of Contents

Section	Description	Page Number
1.0	Cautions and Safety Warnings	3
2.0	Scope	4
3.0	Quick Checklist	4
4.0	General Preparations Before Use	5
5.0	Operation	9
6.0	Service and Maintenance	11
7.0	Storage Instructions	12
8.0	Frequently Asked Questions	13
9.0	Revision History	14
Appendix A1	EC Declaration of Conformity	16
Appendix A2	UKCA Declaration of Conformity	17
Figure 1	MP-0130 Manual Pump Kit	18
Figure 2	MP-0130 Manual Pump Kit	18
Figure 3	AP-0532 Air-Driven Pump Kit	19
Figure 4	AP-6048 Air-Driven Pump Kit	20
Figure 5	MP-6809 Manual Pump Kit	21
Figure 6	MP-6809 Manual Pump Kit	21
Figure 7	AP-10478 Air-Driven Pump Kit	23



215 Clinton Road
 New Hartford, NY 13413
 Tel: +1 315 768 4855
 Fax: +1 315 768 4941
 Email: info@riverhawk.com

CUSTOMER'S INFORMATION BOX
 CONTENTS ARE INDEPENDENT OF RIVERHAWK DOCUMENT CONTROL

GE DRAWING NUMBER	REV
373A4058	

1.0 Cautions and Safety Warnings

WARNING

Improper tool use and the failure to follow the correct procedures are the primary root causes of tool failures and personal injuries. A lack of training or experience can lead to incorrect equipment installation or incorrect pump use. Only trained operators with careful, deliberate actions should use hydraulic pumps and hydraulic tools.

CAUTION

Personal injury and equipment damage can occur if the proper health and safety codes and procedures are not followed. Contact the site's health and safety office to determine all applicable safety rules and regulations.

WARNING

The proper personal protective equipment must be worn at all times.

CAUTION

Riverhawk recommends that the hydraulic pumps should be returned to Riverhawk for periodic inspections. Replacement of obsolete hydraulic pumps is recommended. Functional upgrades are also recommended. The Riverhawk Service Returns Coordinator should be notified 3-6 months prior to a planned outage to schedule an inspection service.

CAUTION

Air can become trapped in the hydraulic system when connecting hoses and tensioners to a hydraulic pump. Refer to the hydraulic tensioner's instructions to determine if bleeding the air out of the hydraulic system is required.

CAUTION

Depending on the amount of air present in the connected hoses or tensioners, it may be necessary to refill the pump with hydraulic oil.

WARNING

Check the maximum working pressures of the hoses and tensioners connected to the pump. Do not exceed the maximum working pressure of the pump, hose, or tensioner.



215 Clinton Road
New Hartford, NY 13413
Tel: +1 315 768 4855
Fax: +1 315 768 4941
Email: info@riverhawk.com

CUSTOMER'S INFORMATION BOX

CONTENTS ARE INDEPENDENT OF RIVERHAWK DOCUMENT CONTROL

GE DRAWING NUMBER	REV
373A4058	

Revision H
Page 3 of 22

2.0 Scope

This document describes the proper use of a Riverhawk hydraulic pump kit.

Riverhawk P/N	GE VENDOC P/N	Description
MP-0130	359B2506	Manual Hydraulic Pump Kit
MP-6809	373A4084	Manual Hydraulic Pump Kit
AP-0532	359B2502	Air-Driven Hydraulic Pump Kit
AP-6048	269B8768	Air-Driven Hydraulic Pump Kit
AP-10478	101B0817	Air-Driven Hydraulic Pump Kit

The figures at the end of this manual depict the location of the components used to operate the hydraulic pump kits.

3.0 Quick Checklist

The following checklist is intended as a summary of the steps needed to use the Riverhawk-supplied hydraulic pump kits. New personnel or those experienced personnel who have not used the Riverhawk equipment recently are encouraged to read the entire manual.

- Check oil level in the hydraulic pump. (Refer to section 6.2 for more information)
- For the air-driven hydraulic pumps, ensure that the pump's air pressure is set between:
 - AP-0532: 80 psi [5.5 bar] to 100 psi [6.9 bar]
 - AP-6048: 90 psi [6.2 bar] to 110 psi [7.6 bar]
 - AP-10478: 6.2 bar [620 Kpa] to 7.6 bar [760 KPa]
- Check hydraulic pressure gage for any damage.
- Test the pump before connecting the hydraulic hose or tensioner.
 - Manual Pump (Refer to section 4.1.1 for more information)
 - Air Driven Pump (Refer to section 4.1.2 for more information)
- Check hydraulic hose for any damage. (Refer to section 4.2 for more information)
- Check hose collar setting. (Refer to sections 4.2.1 and 4.2.2 for more information)
- Check cleanliness of pump port and hose connection.



215 Clinton Road
 New Hartford, NY 13413
 Tel: +1 315 768 4855
 Fax: +1 315 768 4941
 Email: info@riverhawk.com

CUSTOMER'S INFORMATION BOX
 CONTENTS ARE INDEPENDENT OF RIVERHAWK DOCUMENT CONTROL

GE DRAWING NUMBER	REV
373A4058	

Revision H
 Page 4 of 22

- Connect the hydraulic pump to the hydraulic hose.
- Connect the hydraulic hose to the tensioner in accordance with the tensioner's instructions

4.0 General Preparations before Use

4.1 Check Hydraulic Pump Kit

4.1.1 Check Manual Hydraulic Pump Kit

CAUTION

Riverhawk recommends that the hydraulic pumps should be returned to Riverhawk for periodic inspections. Replacement of obsolete hydraulic pumps is recommended. Functional upgrades are also recommended. The Riverhawk Service Returns Coordinator should be notified 3-6 months prior to a planned outage to schedule an inspection service.

Check the pump kit for any visible signs of damage. Do not use if the pump is damaged.

The pump kit is shipped from the Riverhawk factory full of hydraulic oil. Verify oil level as described in section 6.2.1.

Check hydraulic pressure gage for any damage.

Review section 5.1 for operating instructions prior to testing the pump.

Test pump by dead-heading (leave port plug in place) and pump the lever arm. The pressure gauge should build pressure and then hold the steady pressure when the lever is motionless.

4.1.2 Check Air-Driven Hydraulic Pump Kit

CAUTION

Riverhawk recommends that the hydraulic pumps should be returned to Riverhawk for periodic inspections. Replacement of obsolete hydraulic pumps is recommended. Functional upgrades are also recommended. The Riverhawk Service Returns Coordinator should be notified 3-6 months prior to a planned outage to schedule an inspection service.

Check the pump kit for any visible signs of damage. Do not use if the pump is damaged.



215 Clinton Road
New Hartford, NY 13413
Tel: +1 315 768 4855
Fax: +1 315 768 4941
Email: info@riverhawk.com

CUSTOMER'S INFORMATION BOX
CONTENTS ARE INDEPENDENT OF RIVERHAWK DOCUMENT CONTROL

GE DRAWING NUMBER	REV
373A4058	

Revision H
Page 5 of 22

The pump kit is shipped from the Riverhawk factory full of hydraulic oil. Verify oil level as described in section 6.2.3.

Check hydraulic pressure gage for any damage.

The pump reservoir cap is sealed for shipment. Replace the grey shipping plug with the red plastic reservoir cap.

A supply of clean, dry air is required. Lubricated air is not required.

Attach the male air fittings to the pump's air filter-regulator. Attach the female air fitting to the air hose.

Couple the air hose to the air filter-regulator and adjust the air filter-regulator knob until the air pressure gage reads the pressure level marked on the pump. For AP-0532, the air supply pressure should be set to within the range of 80 psi [5.5 bar] to 100 psi [6.9 bar]. For AP-6048, the air supply pressure should be set to within the range of 90 psi [6.2 bar] to 110 psi [7.6 bar].

Review section 5.2 for operating instructions prior to testing the pump.

Test pump by dead-heading (leave port plug in place) and activate the pump. The pressure gauge should build pressure and then hold the steady pressure when the pump stops.

4.2 Check Hydraulic Hose

Check the hydraulic hose for any damage including bent hose ends, kinked hose and split outer lining. If any damage is found, replace the hose immediately by contacting Riverhawk Company.



215 Clinton Road
New Hartford, NY 13413
Tel: +1 315 768 4855
Fax: +1 315 768 4941
Email: info@riverhawk.com

CUSTOMER'S INFORMATION BOX
CONTENTS ARE INDEPENDENT OF RIVERHAWK DOCUMENT CONTROL

GE DRAWING NUMBER	REV
373A4058	

4.2.1 The 1/4" High Pressure Fitting Assembly

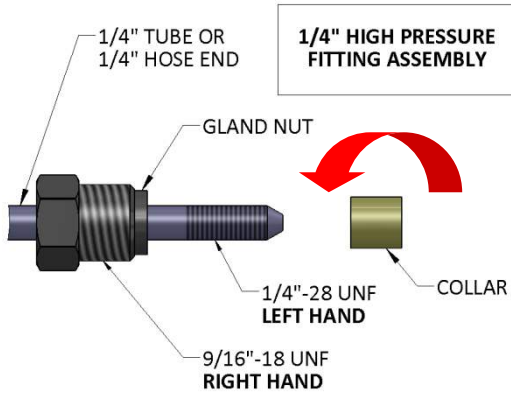

Illustration 1

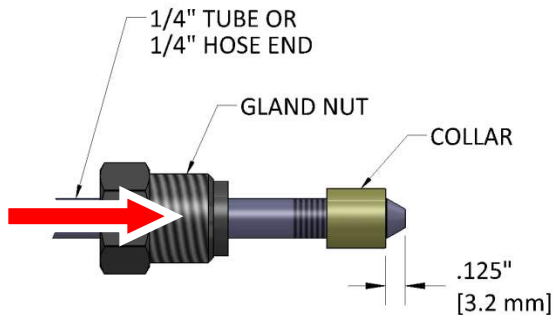

Illustration 2

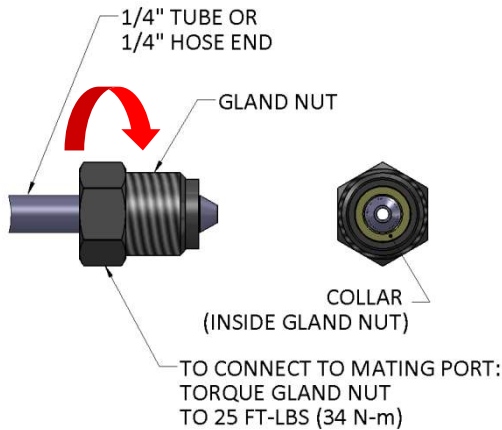

Illustration 3

The Riverhawk hydraulic hose may use a 1/4" High Pressure Fitting to connect to a tensioner. The hose connector is made from a three piece assembly: a gland nut, a collar, and a 1/4" tube or 1/4" hose end. (See Illustration 1)

To assembly the fitting, slide the gland nut over the 1/4" tube or 1/4" hose end. Turn the collar counter-clockwise (**left hand** thread) on to the tube or hose end as shown in Illustration 1.

The collar should be placed .125" (3.2 mm) from the tip of the cone. (See Illustration 2) It may be necessary to adjust this collar with a set of vise-grip pliers. Be careful to not strip the threads off the tube or hose end.

Slide the gland nut down over the collar. (See Illustration 3) Insert the 1/4" tube or 1/4" hose end into tensioner or hydraulic pump. While firmly holding the tube or hose end to stop it from rotating, turn the gland nut clockwise (**right hand** thread) and torque the gland nut to 25 FT-LBS (34 N-m).

Tips:

- Make sure all parts are clean and free from debris.
- Protect the cone on the end of the 1/4" tube or 1/4" hose end from scratches as this is the sealing surface.
- Replace red plastic caps when finished to protect the threads and cone.

CUSTOMER'S INFORMATION BOX
 CONTENTS ARE INDEPENDENT OF RIVERHAWK DOCUMENT CONTROL

GE DRAWING NUMBER	REV
373A4058	



215 Clinton Road
 New Hartford, NY 13413
 Tel: +1 315 768 4855
 Fax: +1 315 768 4941
 Email: info@riverhawk.com

4.2.2 The 3/8" High Pressure Fitting Assembly

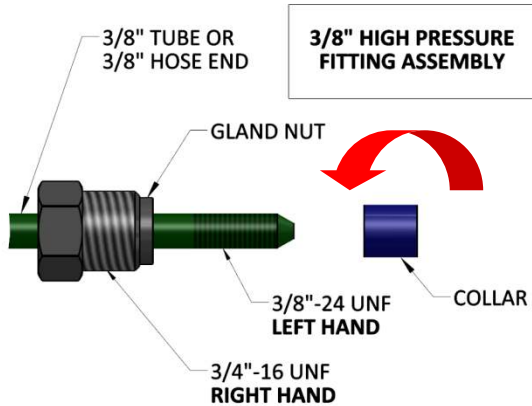

Illustration 4

The Riverhawk hydraulic hose may use a 3/8" High Pressure Fitting to connect to a tensioner. The hose connector is made from a three piece assembly: a gland nut, a collar, and a 3/8" tube or 3/8" hose end. (See Illustration 4)

To assembly the fitting, slide the gland nut over the 3/8" tube or 3/8" hose end. Turn the collar counter-clockwise (**left hand** thread) on to the tube or hose end as shown in Illustration 4.

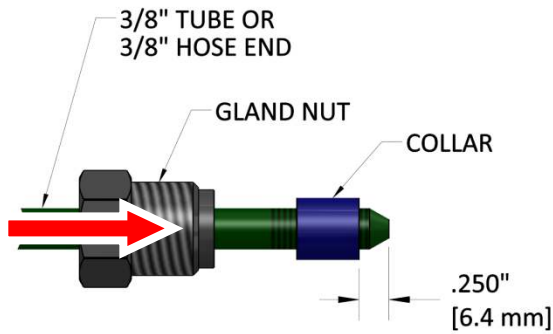

Illustration 5

The collar should be placed .250" (6.4 mm) from the tip of the cone. (See Illustration 5) It may be necessary to adjust this collar with a set of vise-grip pliers. Be careful to not strip the threads off the tube or hose end.

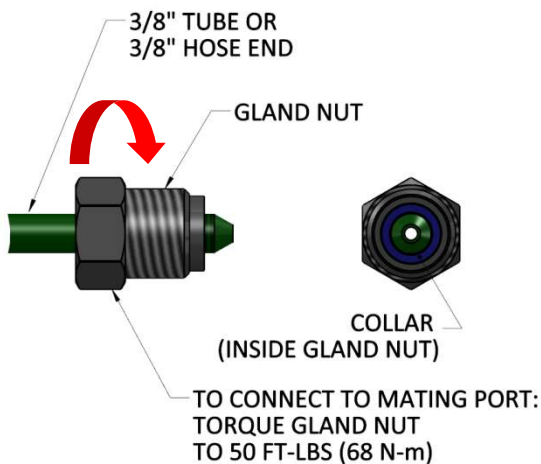

Illustration 6

Slide the gland nut down over the collar. (See Illustration 6) Insert the 3/8" tube or 3/8" hose end into tensioner or hydraulic pump. While firmly holding the tube or hose end to stop it from rotating, turn the gland nut clockwise (**right hand** thread) and torque the gland nut to 50 FT-LBS (68 N-m).

Tips:

- Make sure all parts are clean and free from debris.
- Protect the cone on the end of the 3/8" tube or 3/8" hose end from scratches as this is the sealing surface.
- Replace red plastic caps when finished to protect the threads and cone.

CUSTOMER'S INFORMATION BOX
CONTENTS ARE INDEPENDENT OF RIVERHAWK DOCUMENT CONTROL

GE DRAWING NUMBER	REV
373A4058	



215 Clinton Road
New Hartford, NY 13413
Tel: +1 315 768 4855
Fax: +1 315 768 4941
Email: info@riverhawk.com

4.3 Check Hydraulic Port in the Pump and Tensioner

Before connecting the hydraulic hose to the pump or tensioner, check the hydraulic port for grit, dirt, and other debris. Clean with a brush and, if necessary, with a volatile solvent such as acetone. Do not force the debris deeper into the port.

4.4 Check Hydraulic Tensioner

Refer to the hydraulic tensioner instruction manual for inspection procedure.

5.0 Operation

5.1 Manual Pump Operation

The figures 1, 2, 5, and 6 at the end of this manual depict the location of the components used to operate the manual pump kits.

Step #1: Connect the pump to the tensioner with the appropriate hydraulic hose and open the release knob.

WARNING

Check the maximum working pressures of the hoses and tensioners connected to the pump. Do not exceed the maximum working pressure of the pump, hose, or tensioner.

Step #2: Follow the tensioner's instructions on how to install the tensioner.

Step #3: Follow the tensioner's instructions describing when to pressurize the hydraulic system.

CAUTION

Air can become trapped in the hydraulic system when connecting hoses and tensioners to a hydraulic pump. Refer to the hydraulic tensioner's instructions to determine if bleeding the air out of the hydraulic system is required.

CAUTION

Depending on the amount of air present in the connected hoses or tensioners, it may be necessary to refill the pump with hydraulic oil.

Step #4: Close the release knob and pump the lever until the target hydraulic pressure is reached.



215 Clinton Road
New Hartford, NY 13413
Tel: +1 315 768 4855
Fax: +1 315 768 4941
Email: info@riverhawk.com

CUSTOMER'S INFORMATION BOX
CONTENTS ARE INDEPENDENT OF RIVERHAWK DOCUMENT CONTROL

GE DRAWING NUMBER	REV
373A4058	

Revision H
Page 9 of 22

Step #5: Once the target pressure is reached, perform the steps required by the tensioner's instructions.

Step #6: To relieve the hydraulic pressure, open the release knob to allow the tensioner to fully retract. The tensioner will take approximately 30 seconds to retract.

It is the best practice to leave the release knob in the open position while the tensioner is connected to the pump. Even though the pump's pressure gage reads no pressure, the tensioner can still be retracting.

5.2 Air-Driven Pump Operation

The figures 3, 4, and 7 at the end of this manual depict the location of the components used to operate the hydraulic pump kits.

Refer to the inside cover of the pump for instructions that are specific to the pump. The following sections are generic instructions that may be superseded by the instructions inside the pump.

Step #1: Connect the pump to the tensioner with the appropriate hydraulic hose.

WARNING

Check the maximum working pressures of the hoses and tensioners connected to the pump. Do not exceed the maximum working pressure of the pump, hose, or tensioner.

Step #2: Follow the tensioner's instructions on how to install the tensioner.

Step #3: Follow the tensioner's instructions describing when to pressurize the hydraulic system.

CAUTION

Air can become trapped in the hydraulic system when connecting hoses and tensioners to a hydraulic pump. Refer to the hydraulic tensioner's instructions to determine if bleeding the air out of the hydraulic system is required.

CAUTION

Depending on the amount of air present in the connected hoses or tensioners, it may be necessary to refill the pump with hydraulic oil.

Step #4: Set the hydraulic pressure to zero by turning the hydraulic pressure control knob counterclockwise until it stops.



215 Clinton Road
New Hartford, NY 13413
Tel: +1 315 768 4855
Fax: +1 315 768 4941
Email: info@riverhawk.com

CUSTOMER'S INFORMATION BOX
CONTENTS ARE INDEPENDENT OF RIVERHAWK DOCUMENT CONTROL

GE DRAWING NUMBER	REV
373A4058	

Revision H
Page 10 of 22

Step #5: Activate the pump's switch.

Step #6: Slowly turn the hydraulic pressure knob clockwise until the target hydraulic pressure is reached.

Step #7: Once the target pressure is reached, perform the steps required by the tensioner's instructions.

Step #8: Deactivate the pump's switch to release the hydraulic pressure.

It is the best practice to leave the air-driven pump connected to the tensioner. Even though the pump's pressure gage reads no pressure, the tensioner can still be retracting.

6.0 Service and Maintenance

6.1 Replacement Hydraulic Oil

Lost oil should be replaced with Enerpac Hydraulic Oil. ISO 32 or equivalent hydraulic oil may be substituted. Do not overfill the pump's oil reservoir.

6.2 Hydraulic Oil Level

6.2.1 Oil Level for MP-0130 Manual Pump Kits

The filler hole on the hydraulic oil reservoir is also used to check the level. Position the pump with the pump head facing downwards and remove the filler plug. The oil level is correct when the oil reaches the bottom edge of the filler hole. Refit the filler plug and tightened to a maximum torque of 175in-lbs [20Nm].

6.2.2 Oil Level for MP-6809 Manual Pump Kits

The filler hole on the hydraulic oil reservoir is also used to check the level. The oil level is correct when the oil reaches the bottom edge of the filler hole. Refit the filler plug and tightened by hand until cap stops.



215 Clinton Road
New Hartford, NY 13413
Tel: +1 315 768 4855
Fax: +1 315 768 4941
Email: info@riverhawk.com

CUSTOMER'S INFORMATION BOX
CONTENTS ARE INDEPENDENT OF RIVERHAWK DOCUMENT CONTROL

GE DRAWING NUMBER	REV
373A4058	

Revision H
Page 11 of 22

6.2.3 Oil Level for Air-Driven Pump Kits

Place the pump kit on a flat level surface and remove the grey shipping plug or the red plastic reservoir cap. The oil level is correct when the oil is approximately 1 inch (25 mm) below the top of the reservoir. A flashlight may be helpful to see the oil level. Refit the grey shipping plug or the red plastic reservoir cap.

6.3 Maintenance

Lubricate the moving parts on the manual pump.

Check the air filter on the air-driven pump kit for excessive dirt and debris buildup.

Examine the pump's hydraulic pressure gage for damage. In the absence of a site's preventative maintenance schedule, Riverhawk recommends a gage calibration every two years.

Check the hydraulic ports for grit, dirt, and other debris. Clean with a brush and, if necessary, with a volatile solvent such as acetone. Do not force the debris deeper into the port.

Check the hydraulic hose for any damage including bent hose ends and split outer lining. If any damage is found, replace the hose immediately by contacting the Riverhawk Company. Place the plastic end caps on the hose ends to protect the hose ends from damage.

7.0 Storage Instructions

7.1 MP-0130 and MP-6809 Manual Hydraulic Pump Kit

Disconnect the hose from pump and place the metal plug into pump port. Place the plastic end caps on the hose ends to protect the hose ends from damage.

Check the hydraulic hose for any damage including bent hose ends and split outer lining. If any damage is found, replace the hose immediately by contacting the Riverhawk Company.

Wind the hydraulic hose around the pump and secure in place with the hose clamps.

Make sure the pump has not suffered any external damage as the result of impacts, mishandling, etc.



215 Clinton Road
New Hartford, NY 13413
Tel: +1 315 768 4855
Fax: +1 315 768 4941
Email: info@riverhawk.com

CUSTOMER'S INFORMATION BOX
CONTENTS ARE INDEPENDENT OF RIVERHAWK DOCUMENT CONTROL

GE DRAWING NUMBER	REV
373A4058	

Revision H
Page 12 of 22

Clean pump and check that there are no external hydraulic oil leaks. If any leaks are observed, contact Riverhawk for repair options.

Lubricate the pump's moving parts before returning the pump to storage.

Place the hydraulic pump kit into the original shipping container.

7.2 AP-0532, AP-6048, and AP-10478 Air-Driven Hydraulic Pump Kits

Disconnect the hose from pump and place the metal plug into pump port. Place the plastic end caps on the hose ends to protect the hose ends from damage.

Check the hydraulic hose for any damage including bent hose ends and split outer lining. If any damage is found, replace the hose immediately by contacting the Riverhawk Company.

Wind the hydraulic hose into a circle no smaller than 14" (360mm) in diameter and place into the original shipping container.

Make sure the pump has not suffered any external damage as the result of impacts, mishandling, etc.

Clean pump and check that there are no external hydraulic oil leaks. If any leaks are observed, contact Riverhawk for repair options.

The red oil reservoir cap should be removed and stored inside the pump box with the extra air hose fittings. Place the grey and black storage plug into the oil reservoir opening and tighten to secure the oil from spillage

Place the hydraulic pump kit into the original shipping container.

8.0 Frequently Asked Questions

This section contains some frequently asked questions and problems. If the steps listed here do not solve your problem, contact the Riverhawk Company thru our website, email, or phone call.

Q: Can I rent a hydraulic tensioner kit?

A: Yes, Riverhawk has rental tensioner kits available for most of our hydraulic tensioners.



215 Clinton Road
New Hartford, NY 13413
Tel: +1 315 768 4855
Fax: +1 315 768 4941
Email: info@riverhawk.com

CUSTOMER'S INFORMATION BOX
CONTENTS ARE INDEPENDENT OF RIVERHAWK DOCUMENT CONTROL

GE DRAWING NUMBER	REV
373A4058	

Q: The hydraulic pump appears to be leaking or does not build pressure.

A: Check the hose connection to the hydraulic pump. If the hose’s high pressure fitting is not assembled correctly to the pump, it may look like the pump is leaking. Refer to sections 4.2.1 or 4.2.2 for the correct use of the high pressure fittings.

Inspect and clean the male cone at the end of the hose, the cone must be free of damage and debris. Also, inspect and clean the female cone at the bottom of the hydraulic port, the cone must also be free of damage and debris.

Check pump by dead heading as described in section 4.1.1 or section 4.1.2. If the problem continues, contact Riverhawk for guidance.

Q: The hydraulic hose appears to be leaking with gland nut tight.

A: If the high pressure fitting is not assembled correctly, it may look like the hose is leaking. Refer to sections 4.2.1 or 4.2.2 for the correct use of the high pressure fittings.

Inspect and clean the male cone at the end of the hose, the cone must be free of damage and debris. Also, inspect and clean the female cone at the bottom of the hydraulic port, the cone must also be free of damage and debris.

Q: The hydraulic hose has a collar on it that can't be moved by hand.

A: The collar is held in place with a thread locking compound. This prevents the collar from moving too easily. Refer to sections 4.2.1 or 4.2.2 for the correct use of the high pressure fittings. It may be necessary to adjust this collar with a set of vise-grip pliers. Be careful to not strip the threads off the tube or hose end.

9.0 Revision History

Revision Letter	Effective Date	Description
H	Jan 24, 2024	Added AP-10478 to title page, Section 2.0, Section 3.0, and Section 7.2
G	Dec 4, 2023	Revise air pressure required for AP-6048 pumps to 90 psi [6.2 bar] to 110 psi [7.6 bar] from 80 psi [5.5 bar] to 100 psi [6.9 bar]



215 Clinton Road
 New Hartford, NY 13413
 Tel: +1 315 768 4855
 Fax: +1 315 768 4941
 Email: info@riverhawk.com

CUSTOMER'S INFORMATION BOX
 CONTENTS ARE INDEPENDENT OF RIVERHAWK DOCUMENT CONTROL

GE DRAWING NUMBER	REV
373A4058	

Instruction Manual IM-293

Revision Letter	Effective Date	Description
F	Jan 24, 2022	Updated EC Declaration of Conformity; Added UKCA Declaration of Conformity
E	Nov 14, 2017	Section 4.1.2, Section 6.2.3 was Section 6.2.2
D	Jul 11, 2016	Added hydraulic pressure gage references to sections 3, 4.1.1, 4.1.2, and 6.3
C	May 5, 2015	Added MP-6809 Manual Pump Kit
B	Mar 26, 2014	Added AP-6048 Air-Driven Pump Kit, Added Appendix A1
A	Oct 22, 2012	Reformatted, general update to warnings and cautions
-	Aug 16, 2012	Released



215 Clinton Road
 New Hartford, NY 13413
 Tel: +1 315 768 4855
 Fax: +1 315 768 4941
 Email: info@riverhawk.com

CUSTOMER'S INFORMATION BOX
 CONTENTS ARE INDEPENDENT OF RIVERHAWK DOCUMENT CONTROL

GE DRAWING NUMBER	REV
373A4058	

Appendix A1

EC Declaration of Conformity

Manufacturer: Riverhawk Company
Address: 215 Clinton Road
New Hartford, NY 13413, USA

The hydraulic pump and bolt tensioning tool described in this manual are used for installing and applying tension to large bolts that are specifically designed by Riverhawk Company to be tensioned hydraulically.

All applicable sections of European Directive 2006/42/EC for machinery have been applied and fulfilled in the design and manufacture of the hydraulic pump and bolt tensioning tool described in this manual. Reference also ISO 12100:2010, ISO 4413:2010, and ISO 4414:2010.

Furthermore, this equipment has been manufactured under the Riverhawk quality system per EN ISO 9001:2015

Consult the Declaration of Conformance included with the shipment of this equipment that identifies the authorized Riverhawk representative, applicable serial numbers, and appropriate signature.



215 Clinton Road
New Hartford, NY 13413
Tel: +1 315 768 4855
Fax: +1 315 768 4941
Email: info@riverhawk.com

CUSTOMER'S INFORMATION BOX
CONTENTS ARE INDEPENDENT OF RIVERHAWK DOCUMENT CONTROL

GE DRAWING NUMBER	REV
373A4058	

Revision H
Page 16 of 22

Appendix A2

UKCA Declaration of Conformity

Manufacturer: Riverhawk Company
Address: 215 Clinton Road
New Hartford, NY 13413, USA

The hydraulic pump and bolt tensioning tool described in this manual are used for installing and applying tension to large bolts that are specifically designed by Riverhawk Company to be tensioned hydraulically.

All applicable sections of Supply of Machinery (Safety) 2008 have been applied and fulfilled in the design and manufacture of the hydraulic pump and bolt tensioning tool described in this manual. Reference also ISO 12100:2010, ISO 4413:2010, and ISO 4414:2010.

Furthermore, this equipment has been manufactured under the Riverhawk quality system per EN ISO 9001:2015

Consult the Declaration of Conformance included with the shipment of this equipment that identifies the authorized Riverhawk representative, applicable serial numbers, and appropriate signature.



215 Clinton Road
New Hartford, NY 13413
Tel: +1 315 768 4855
Fax: +1 315 768 4941
Email: info@riverhawk.com

CUSTOMER'S INFORMATION BOX
CONTENTS ARE INDEPENDENT OF RIVERHAWK DOCUMENT CONTROL

GE DRAWING NUMBER	REV
373A4058	

Revision H
Page 17 of 22

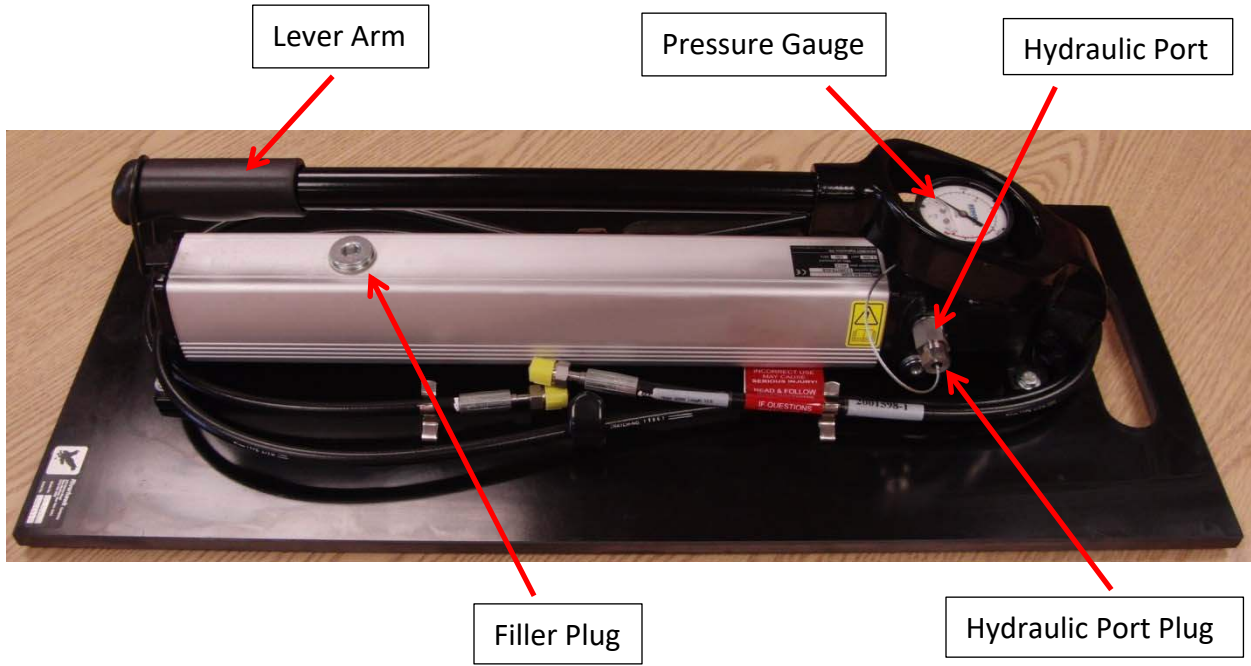

Figure 1 – Sample Picture of MP-0130 Hydraulic Pump with the Hydraulic Port plugged for testing (Right Side)

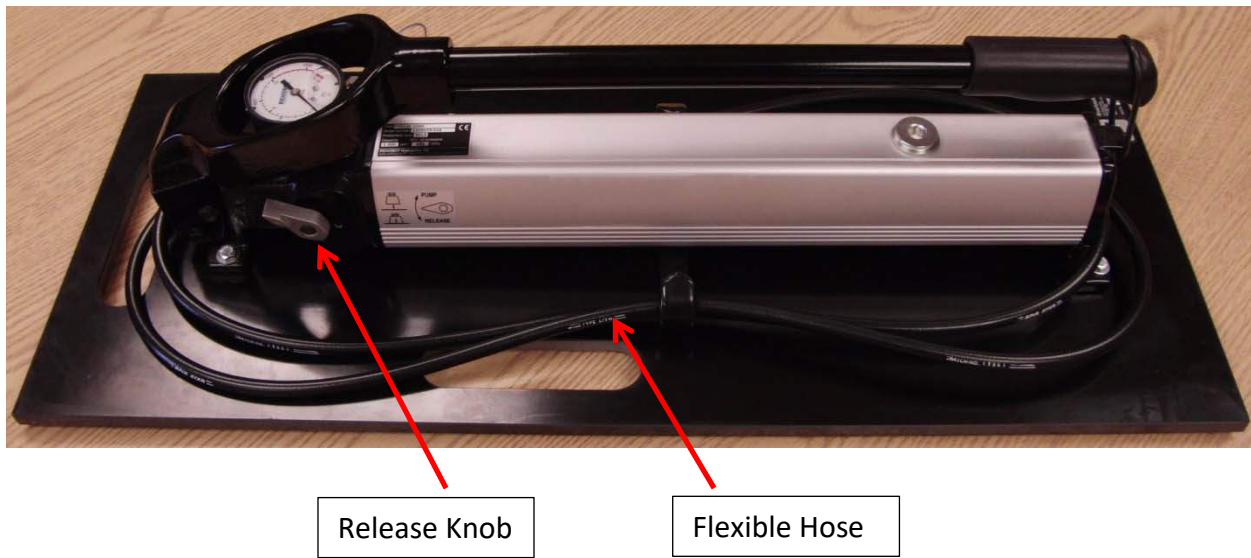

Figure 2 – Sample Picture of MP-0130 Hydraulic Pump with the Hydraulic Port plugged for testing (Left Side)



215 Clinton Road
 New Hartford, NY 13413
 Tel: +1 315 768 4855
 Fax: +1 315 768 4941
 Email: info@riverhawk.com

CUSTOMER'S INFORMATION BOX
 CONTENTS ARE INDEPENDENT OF RIVERHAWK DOCUMENT CONTROL

GE DRAWING NUMBER	REV
373A4058	

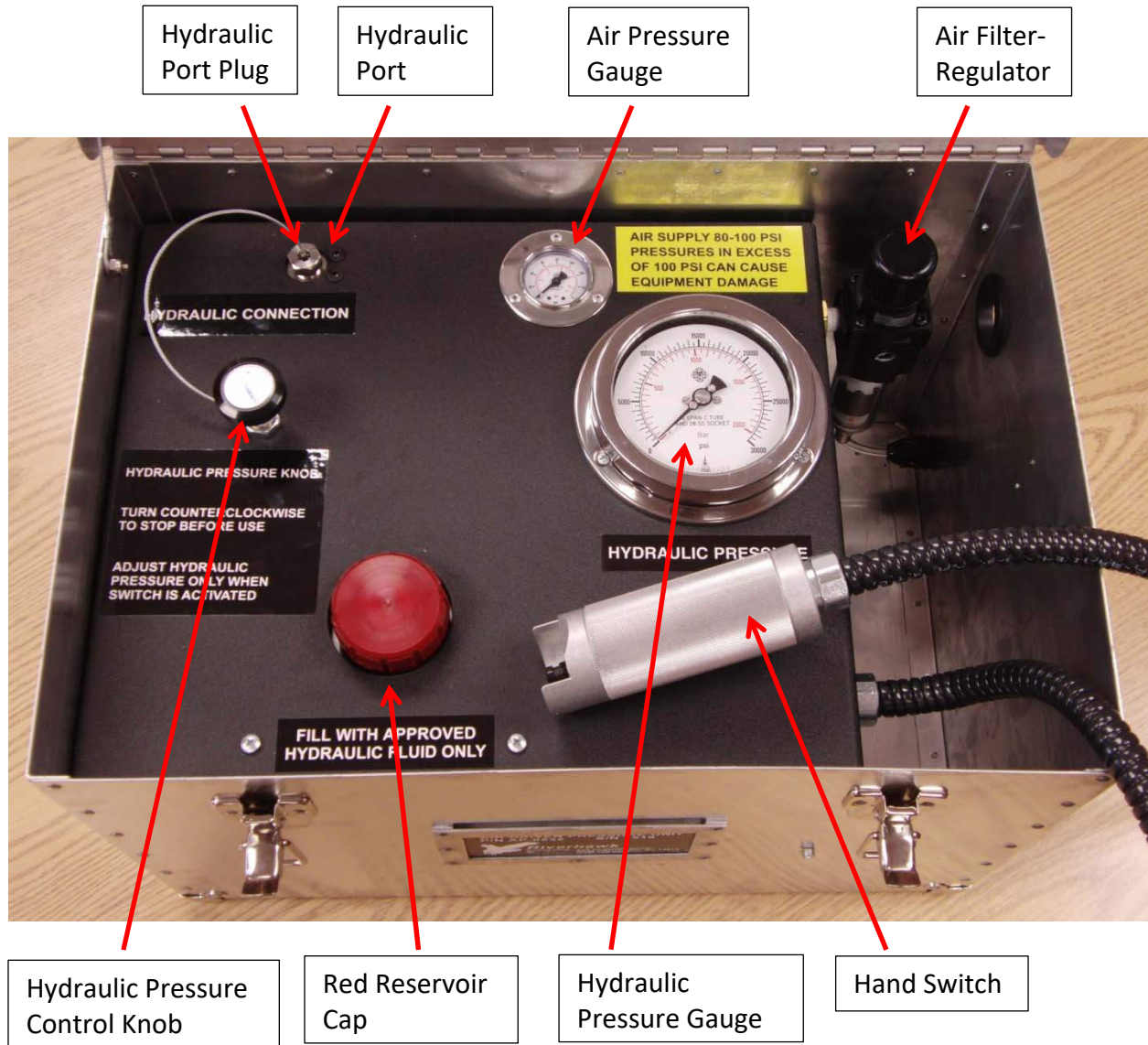

Figure 3 - Sample Picture of AP-0532 Hydraulic Pump with the Hydraulic Port plugged for testing (Top View)



215 Clinton Road
 New Hartford, NY 13413
 Tel: +1 315 768 4855
 Fax: +1 315 768 4941
 Email: info@riverhawk.com

CUSTOMER'S INFORMATION BOX
 CONTENTS ARE INDEPENDENT OF RIVERHAWK DOCUMENT CONTROL

GE DRAWING NUMBER	REV
373A4058	

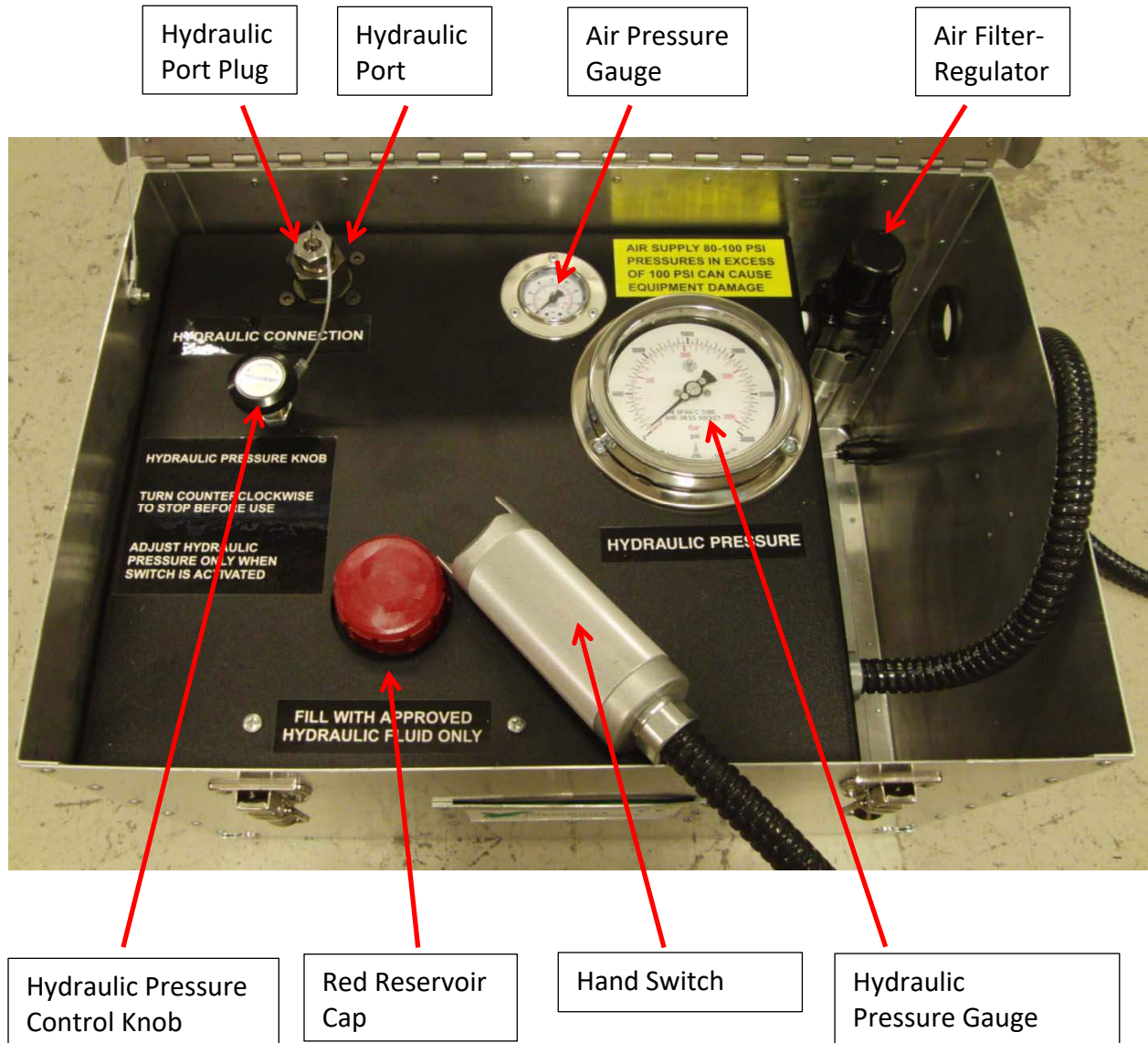

Figure 4 - Sample Picture of AP-6048 Hydraulic Pump with the Hydraulic Port plugged for testing (Top View)



215 Clinton Road
 New Hartford, NY 13413
 Tel: +1 315 768 4855
 Fax: +1 315 768 4941
 Email: info@riverhawk.com

CUSTOMER'S INFORMATION BOX
 CONTENTS ARE INDEPENDENT OF RIVERHAWK DOCUMENT CONTROL

GE DRAWING NUMBER	REV
373A4058	



Figure 5 – Sample Picture of MP-6809 Hydraulic Pump with the Hydraulic Port plugged for testing (Right Side)

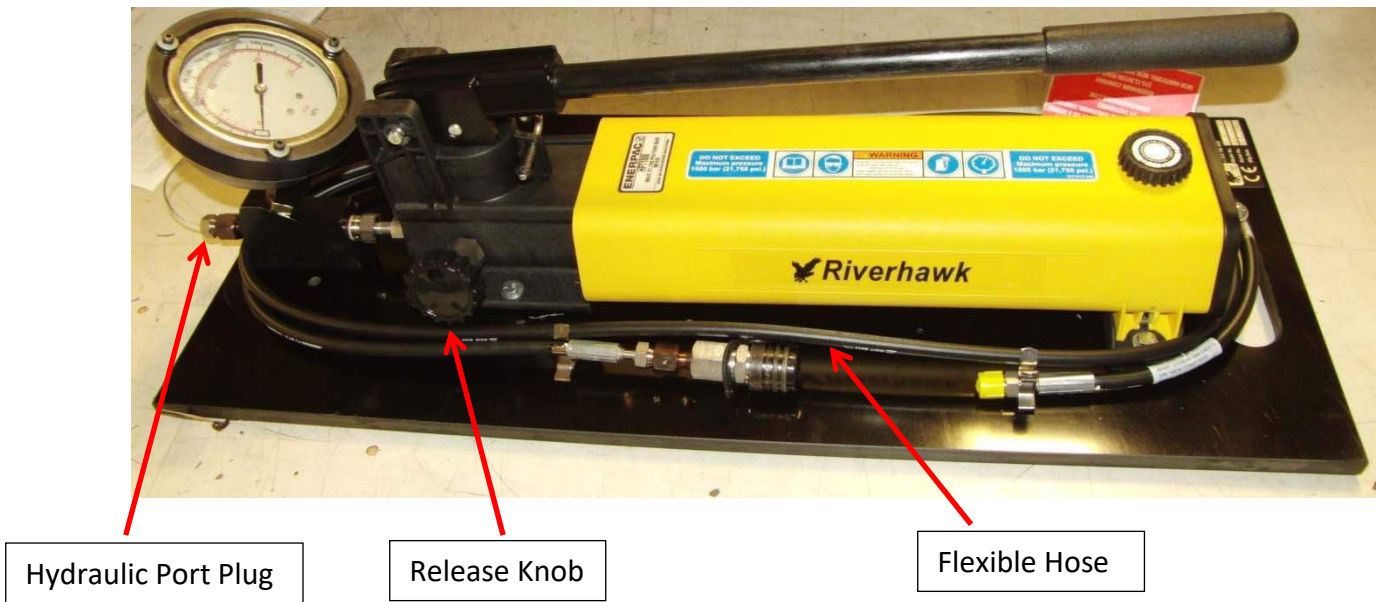

Figure 6 – Sample Picture of MP-6809 Hydraulic Pump with the Hydraulic Port plugged for testing (Left Side)



215 Clinton Road
New Hartford, NY 13413
Tel: +1 315 768 4855
Fax: +1 315 768 4941
Email: info@riverhawk.com

CUSTOMER'S INFORMATION BOX
CONTENTS ARE INDEPENDENT OF RIVERHAWK DOCUMENT CONTROL

GE DRAWING NUMBER	REV
373A4058	

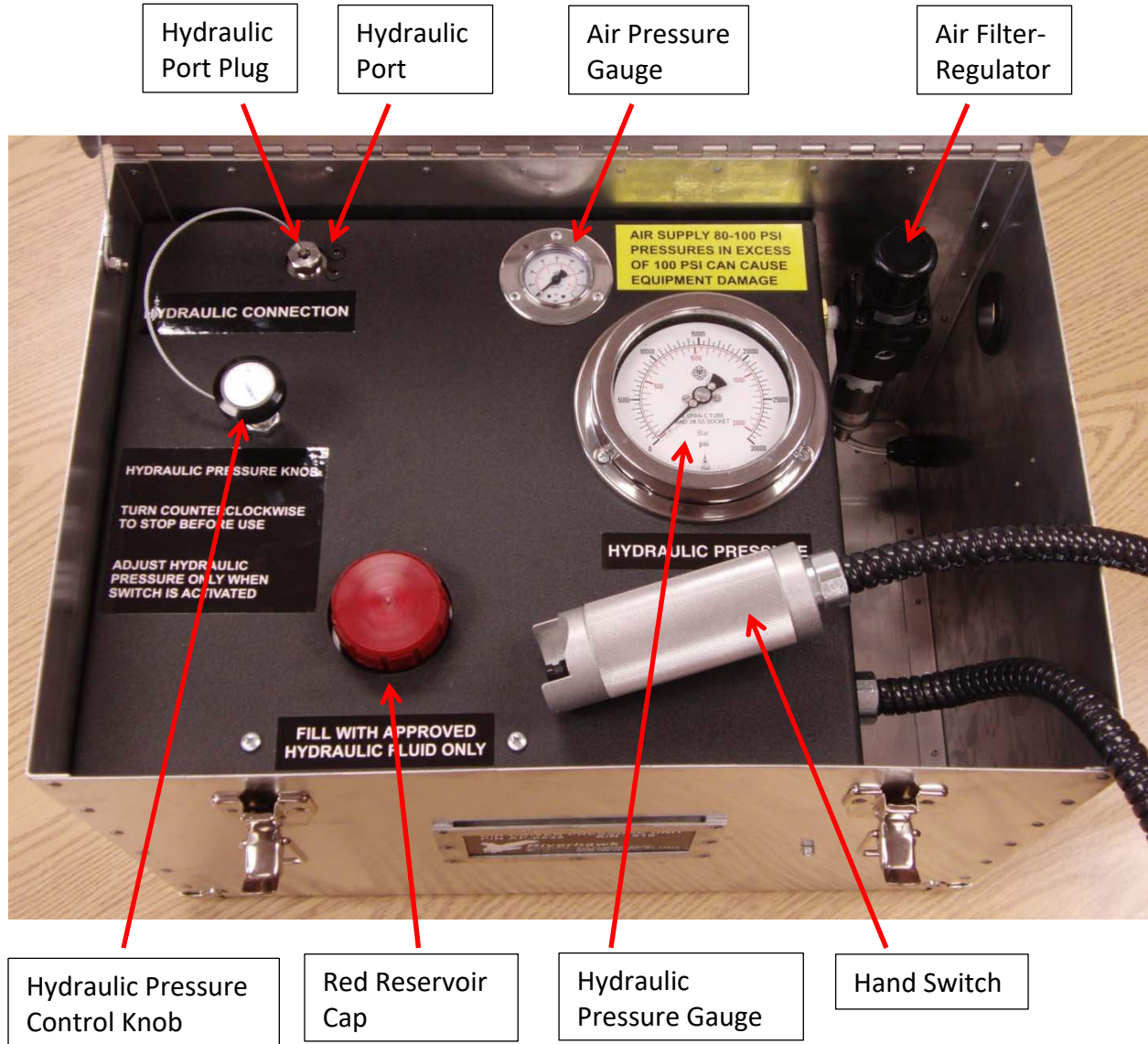

Figure 7 - Sample Picture of AP-10478 Hydraulic Pump with the Hydraulic Port plugged for testing (Top View)



215 Clinton Road
 New Hartford, NY 13413
 Tel: +1 315 768 4855
 Fax: +1 315 768 4941
 Email: info@riverhawk.com

CUSTOMER'S INFORMATION BOX
 CONTENTS ARE INDEPENDENT OF RIVERHAWK DOCUMENT CONTROL

GE DRAWING NUMBER	REV
373A4058	