



INSTRUCTION MANUAL IM-324
For Steam Turbine Tensioned
Studs and Nuts

Applicable Bolting Connections

- D14 Steam Turbine, HP Stub Shaft to Generator Flange
- D14 Steam Turbine, LP to IP Flange
- D652 Steam Turbine, LP to Spool Piece
- D202 Steam Turbine, HP to LP

Applicable GE Ordering Sheet Part Numbers

103T5423P0001	103T5973P0001	117T7310G0001	119T2839G0001
103T5423P0002	103T5973P0002		
103T5423P0003	103T5973P0003	118T5916G0001	121T6055P0001
103T5423P0101	103T5973P0101		121T6055P0002
103T5423P0102	103T5973P0102	119T9669P0001	121T6055P0003
103T5423P0103	103T5973P0103	119T9669P0002	
		119T9669P0003	121T9004G0001
	109T2264G0002		

CUSTOMER'S INFORMATION BOX

CONTENTS ARE INDEPENDENT OF RIVERHAWK DOCUMENT CONTROL

GE Power & Water		GENERAL ELECTRIC COMPANY	
<u>VENDOR SUPPLIED</u>			
GE NOT TO REVISE. GE REVISION LEVEL IS SHOWN ON THIS APPLIQUE. THIS DOCUMENT IS FILED UNDER THE GE DRAWING NUMBER.			
THIS DOCUMENT SHALL BE REVISED IN ITS ENTIRETY. ALL SHEETS OF THIS DOCUMENT ARE THE SAME REVISION LEVEL AS INDICATED IN THIS VENDOR SUPPLIED DRAWING APPLIQUE.			
MLI:		____ OF ____	
GE SIGNATURES	DATE	GE DRAWING NUMBER	REV
CHECKED:		373A4067	
ISSUED:			

The Riverhawk Company reserves the right to update this document without dissemination or notice. The latest revision may be obtained by contacting Riverhawk Company or thru www.riverhawk.com.



Repairs – Rentals
Field Service

215 Clinton Road
 New Hartford, NY 13413
 Tel: +1 315 768 4855
 Fax: +1 315 768 4941
 Email: info@riverhawk.com

Table of Contents

Section	Description	Page Number
1.0	Cautions and Safety Warnings	3
2.0	Scope and GE Part Number Cross Reference	4
3.0	Quick Checklist	7
4.0	General Preparations	10
5.0	Hardware Set Preparations	12
6.0	Stud and Nut Assembly	15
7.0	Hydraulic Tensioner Equipment Assembly	19
8.0	Assembly of Tensioner on Stud	21
9.0	Stud Tensioning	25
10.0	Nut Thread Locking and Wind Plug Installation	28
11.0	Stud and Nut Removal	31
12.0	Storage Instructions	35
13.0	Frequently Asked Questions	36
14.0	Revision History	39
Appendix A1	EC Declaration of Conformity	40
Appendix A2	UKCA Declaration of Conformity	41
Appendix B1	16-Bolt Tensioning Pattern (D14 HPSS - GEN) Record Sheet	42
Appendix B2	16-Bolt Tensioning Pattern (D14 LP-IP) Record Sheet	43
Appendix B3	16-Bolt Tensioning Pattern (D652 LP-Spool Piece) Record Sheet	44
Appendix B4	16-Bolt Tensioning Pattern (D202 HP-LP) Record Sheet	45



215 Clinton Road
 New Hartford, NY 13413
 Tel: +1 315 768 4855
 Fax: +1 315 768 4941
 Email: info@riverhawk.com

CUSTOMER'S INFORMATION BOX
 CONTENTS ARE INDEPENDENT OF RIVERHAWK DOCUMENT CONTROL

GE DRAWING NUMBER	REV
373A4067	

1.0 Cautions and Safety Warnings

WARNING

Improper tool use and the failure to follow the correct procedures are the primary root causes of tool failures and personal injuries. A lack of training or experience can lead to incorrect hardware installation or incorrect tool use. Only trained operators with careful, deliberate actions should use hydraulic tensioners.

CAUTION

Personal injury and equipment damage can occur if the proper health and safety codes and procedures are not followed. Contact the site's health and safety office to determine all applicable safety rules and regulations.

WARNING

The proper personal protective equipment must be worn at all times.

CAUTION

It is especially important to check the condition of the conical thread used to tension the stud. Thread damage from previous abuse can lead to failure of the stud or tensioning equipment

CAUTION

Riverhawk recommends that the tensioner should be returned to Riverhawk for periodic inspections. Replacement of obsolete tensioners is recommended. Functional upgrades are also recommended. The Riverhawk Service Returns Coordinator should be notified 3-6 months prior to a planned outage to schedule an inspection service.

WARNING

A damaged burst disc must be replaced with a burst disc of the same design and pressure rating. Do not substitute a damaged burst disc with a different disc type, a different pressure rating, or a foreign object.

WARNING

To avoid failure, ensure safety, and proper operation, the tensioner assembly must be installed on a stud in the flange before pressurizing the tensioner. Do not use the tensioner at any pressure unless the tool is installed on a stud in a flange.

CAUTION

Personal injury and equipment damage can occur if the puller screw is not securely engaged with the tapered threads of the stud. Proper engagement is achieved when the puller screw is tight in the stud and the tensioner foot is free to turn.



215 Clinton Road
New Hartford, NY 13413
Tel: +1 315 768 4855
Fax: +1 315 768 4941
Email: info@riverhawk.com

CUSTOMER'S INFORMATION BOX
CONTENTS ARE INDEPENDENT OF RIVERHAWK DOCUMENT CONTROL

GE DRAWING NUMBER	REV
373A4067	

Revision H
Page 3 of 45

WARNING

The safety interlock guard must be in place at all times. When the tensioner is pressurized hands must be kept out of designated areas to avoid any potential for personal injury.

CAUTION

Before threading the puller screw into the stud, carefully check the cleanliness of both the stud's and the puller screw's conical threads. Apply a light coat of clean turbine oil or a spray lubricant to the puller screw. This procedure will ease assembly and assure positive mating of the threads before tightening. Do not use "Never Seize" on the conical threads.

CAUTION

Do not tighten the nut while the tool is coming up to pressure; wait until pressure is achieved before attempting to tighten the nut with the spanner ring. If the tool is not properly installed, the tool could jump off the stud while coming up to pressure.

CAUTION

Do not exceed the maximum pressure marked on the tensioner. Excessive pressure can damage the stud and puller screw.

WARNING

FIRE HAZARD: DO NOT heat when tensioner assembly is in place. Personal injury or equipment damage may occur. Use of an Oxy-Acetylene torch is not recommended

WARNING

Do not use a hydraulic tensioner to remove a stud with damaged conical threads.

2.0 Scope and GE Part Number Cross Reference

This document describes the procedure to be used to install the stud, nut and windage plug sets supplied by the Riverhawk Company in the flanges at the HP Stub Shaft to Generator Flange and LP to IP Flange connections.

The various frame configurations covered in this manual are listed in Sections 2.1 through 2.5 with differences as related to connective hardware defined. Listed also are the pertinent hardware drawings (HF-xxxx). These drawings as well as tooling drawings (HT-xxxx) form part of this manual.



215 Clinton Road
New Hartford, NY 13413
Tel: +1 315 768 4855
Fax: +1 315 768 4941
Email: info@riverhawk.com

CUSTOMER'S INFORMATION BOX
CONTENTS ARE INDEPENDENT OF RIVERHAWK DOCUMENT CONTROL

GE DRAWING NUMBER	REV
373A4067	

2.1 D14 Steam Turbine; HP Stub Shaft to Generator Flange

GE Part Number	Riverhawk P/N	GE VENDOC P/N
103T5423P0001	HF-5657	GE 269B8753
103T5423P0002	HF-5657	GE 269B8753
103T5423P0101	HF-5657	GE 269B8753
103T5423P0102	HF-5657	GE 269B8753
109T2264G0002	HF-5657	GE 269B8753
117T7310G0001	HF-5657	GE 269B8753
121T9004G0001	HF-5657	GE 269B8753

The hydraulic tooling used for installation and removal is Riverhawk HT-9754 (formerly HT-5573).

These hardware drawings depict the stud, nut and windage plug set for the D14 HP Stub Shaft to Generator Flange (2-3/4" size, Qty 16).

2.2 D14 Steam Turbine; LP to IP Flange

GE Part Number	Riverhawk P/N	GE VENDOC P/N
103T5973P0001	HF-5656	GE 269B8751
103T5973P0002	HF-5656	GE 269B8751
103T5973P0101	HF-5656	GE 269B8751
103T5973P0102	HF-5656	GE 269B8751

The hydraulic tooling used for installation and removal is Riverhawk HT-9754 (formerly HT-5573).

These hardware drawings depict the stud, nut and windage plug set for the D14 LP to IP Flange (2-3/4" size, Qty 16).

2.3 D652 Steam Turbine; LP to Spool Piece Flange

GE Part Number	Riverhawk P/N	GE VENDOC P/N
119T5916G0001	HF-7453	GE 101B0677
119T9669P0001	HF-7453	GE 101B0677

The hydraulic tooling used for installation and removal is Riverhawk HT-9754 (formerly HT-5573).



215 Clinton Road
 New Hartford, NY 13413
 Tel: +1 315 768 4855
 Fax: +1 315 768 4941
 Email: info@riverhawk.com

CUSTOMER'S INFORMATION BOX
 CONTENTS ARE INDEPENDENT OF RIVERHAWK DOCUMENT CONTROL

GE DRAWING NUMBER	REV
373A4067	

These hardware drawings depict the stud, nut and windage plug set for the D652 LP to Spool Piece Flange (2-3/4" size, Qty 16).

2.4 D202 Steam Turbine; HP to LP

GE Part Number	Riverhawk P/N	GE VENDOC P/N
119T2839G0001	HF-7650	GE 101B0688
121T6055P0001	HF-7650	GE 101B0688

The hydraulic tooling used for installation and removal is Riverhawk HT-9754 (formerly HT-5573).

These hardware drawings depict the stud, nut and windage plug set for the D202 HP to LP Flange (2-3/4" size, Qty 16).

2.5 Hydraulic Tooling

GE Part Number	Riverhawk P/N	GE VENDOC P/N
103T5423P0002	HT-9754	GE 101B0805
103T5423P0003	AP-6048	GE 269B8768
103T5423P0102	HT-9754-FR	GE 101B0805
103T5423P0103	AP-6048-FR	GE 269B8768
103T5973P0002	HT-9754	GE 101B0805
103T5973P0003	AP-6048	GE 269B8768
103T5973P0102	HT-9754-FR	GE 101B0805
103T5973P0103	AP-6048-FR	GE 269B8768
109T2264G0002	HT-9754 AP-6048	GE 101B0805 GE 269B8768
117T7310G0001	HT-9754 AP-6048	GE 101B0805 GE 269B8768
121T9004G0001	HT-9754 AP-6048	GE 101B0805 GE 269B8768
118T5916G0001	HT-9754 AP-6048	GE 101B0805 GE 269B8768
119T9669P0002	HT-9754	GE 101B0805
119T9669P0003	AP-6048	GE 269B8768
121T6055P0002	HT-9754	GE 101B0805
121T6055P0003	AP-6048	GE 269B8768



215 Clinton Road
 New Hartford, NY 13413
 Tel: +1 315 768 4855
 Fax: +1 315 768 4941
 Email: info@riverhawk.com

CUSTOMER'S INFORMATION BOX
 CONTENTS ARE INDEPENDENT OF RIVERHAWK DOCUMENT CONTROL

GE DRAWING NUMBER	REV
373A4067	

3.0 Quick Checklist

The following checklist is intended as a summary of the steps needed to use the Riverhawk-supplied equipment. New personnel or those experienced personnel who have not used the Riverhawk equipment recently are encouraged to read the entire manual.

EQUIPMENT INSPECTION

- Check oil level in hydraulic pump.
- Check air pressure at 90psi [6.2 bar] minimum. (For air-driven pumps)
- Check hydraulic hose for damage.
- Test pump.
- Inspect tensioner for any damage.

NUT AND STUD PREPARATION

- Inspect studs, nuts and windage plugs for any damage.
- Clean the studs, nuts and windage plugs.
- Measure and record stud lengths. (VERY IMPORTANT)
- Lubricate the stud's threads with clean turbine oil or spray lubricant. Lubricate the nut's threads and nut face with clean turbine oil or spray lubricant.
- Install studs and nuts into the flange
- Set stick-out dimension on the D14 LP flange or D14 HP stub shaft side of the flange or D652 Spool Piece side of the flange or D202 LP side of the flange.
- With Allen wrench in backside of stud, firmly seat backside nut using spanner ring and pin wrench.
- Verify stick-out measurement (VERY IMPORTANT)



215 Clinton Road
 New Hartford, NY 13413
 Tel: +1 315 768 4855
 Fax: +1 315 768 4941
 Email: info@riverhawk.com

CUSTOMER'S INFORMATION BOX
 CONTENTS ARE INDEPENDENT OF RIVERHAWK DOCUMENT CONTROL

GE DRAWING NUMBER	REV
373A4067	

TENSIONING (Bolt Installation)

- Check tensioner drawing for correct parts and part numbers.
- Apply a light coat of clean turbine oil or spray lubricant to the puller screw. **DO NOT USE “NEVER SEIZE” ON THE CONICAL THREADS.**
- Install the spanner ring onto the nut.
- Install a puller screw release tape strip into stud. See IM-336 (GE VENDOCS 373A4074)
- Thread the puller screw into the stud.
- Insert an Allen wrench into the back side of the stud.
- Insert another Allen wrench into the puller screw. While holding the stud still, tighten the puller screw until hand tight and then loosen the puller screw 1/2 of a turn. Retighten the puller screw and leave hand tight. **DO NOT BACK OFF PULLER SCREW.**
- Slide the foot assembly over the puller screw and orientate the foot into position.
- Thread the tensioner onto puller screw until it stops. There should be a 1/16” to 3/16” gap between the foot and tensioner.
- Place the guard over the tensioner and position guide pin into the hole in the backside of the stud.
- Tighten the guard’s knurled interlock fitting by hand until it presses firmly against tensioner (no gap).
- Push the center of the interlock fitting towards the tensioner while pulling back on the fitting’s pull tabs until it locks onto the tensioner and release the pull tabs.
- Connect the hydraulic pump to the tensioner and tension to 50%. Consult manual for correct pressure.
- Use the pin wrench to turn the spanner ring to firmly tighten nut with 20 ft·lbs [27 N·m] of torque.
- Release pressure and allow the tensioner to fully retract.



215 Clinton Road
 New Hartford, NY 13413
 Tel: +1 315 768 4855
 Fax: +1 315 768 4941
 Email: info@riverhawk.com

CUSTOMER'S INFORMATION BOX
 CONTENTS ARE INDEPENDENT OF RIVERHAWK DOCUMENT CONTROL

GE DRAWING NUMBER	REV
373A4067	

- Disconnect the hose and release the interlock fitting by pushing the center of the interlock fitting towards the tensioner while pulling back on the fitting's pull tabs.
- Loosen the knurled interlock fitting and remove the guard.
- Unscrew the tensioner from the puller screw.
- Remove the foot, puller screw and spanner ring.
- Move to the next stud in the pattern. Tension all studs to 50% before proceeding to final pressure.
- Repeat above steps at final pressure.
- Measure final stud length and record on stretch datasheets. Calculate final stretch measurement.
- Torque the nuts' set screws.
- Install the windage plugs and torque their set screws.

DETENSIONING (Stud Removal)

- Loosen the windage plugs' set screws and remove the windage plugs from the studs.
- Loosen nuts' set screws
- Inspect and clean studs' conical threads. **Do not continue until ALL debris is removed from the threads!** See instruction manual IM-220 (GE VENDOCs 373A4025). **Do not try to use the tensioner to remove a damaged stud!**
- Apply a light coat of clean turbine oil or spray lubricant to the puller screw. **DO NOT USE "NEVER SEIZE" ON THE CONICAL THREADS.**
- Install the spanner ring onto the nut.
- Thread the puller screw into the stud.



215 Clinton Road
New Hartford, NY 13413
Tel: +1 315 768 4855
Fax: +1 315 768 4941
Email: info@riverhawk.com

CUSTOMER'S INFORMATION BOX
CONTENTS ARE INDEPENDENT OF RIVERHAWK DOCUMENT CONTROL

GE DRAWING NUMBER	REV
373A4067	

- Insert an Allen wrench into the puller screw. Tighten the puller screw until hand tight and then loosen the puller screw 1/2 of a turn. Retighten the puller screw and leave hand tight. **DO NOT BACK OFF PULLER SCREW.**
- Slide the foot assembly over the puller screw and orientate the foot into position.
- Thread the tensioner onto puller screw until it stops. There should be a 1/16" to 3/16" gap between the foot and tensioner.
- Place the guard over the tensioner and position guide pin into the hole in the backside of the stud.
- Tighten the guard's knurled interlock fitting by hand until it presses firmly against tensioner (no gap).
- Push the center of the interlock fitting towards the tensioner while pulling back on the fitting's pull tabs until it locks onto the tensioner and release the pull tabs.
- Connect the hydraulic pump to the tensioner and tension to final pressure. Consult manual for correct pressure.
- Loosen nut with the spanner ring and pin wrench approximately 1/2 of a turn.
- Release pressure and allow the tensioner to fully retract.
- Disconnect the hose and release the interlock fitting by pushing the center of the interlock fitting towards the tensioner while pulling back on the fitting's pull tabs.
- Loosen the knurled interlock fitting and remove the guard.
- Unscrew the tensioner cylinder from the puller screw.
- Remove the foot, puller screw, and spanner ring. It may be necessary to insert an Allen wrench into the backside of the stud to remove the puller screw.
- Move to next stud in pattern

4.0 General Preparations

Read and understand all instructions before installing and tensioning studs.



215 Clinton Road
New Hartford, NY 13413
Tel: +1 315 768 4855
Fax: +1 315 768 4941
Email: info@riverhawk.com

CUSTOMER'S INFORMATION BOX
CONTENTS ARE INDEPENDENT OF RIVERHAWK DOCUMENT CONTROL

GE DRAWING NUMBER	REV
373A4067	

Operators should be trained or have previous experience using Riverhawk tensioning equipment. Training will minimize the chance of improper use of the equipment.

The hydraulic tooling including the hydraulic hoses should be inspected prior to use. Inspection guidelines are listed in the following sub-sections.

This equipment produces very high hydraulic pressures and very high forces. Operators must exercise caution and wear the appropriate personal protective equipment when handling and operating the hydraulic tooling.

High-pressure oil from the hydraulic pump pressurizes the tensioner which generates a very large force that actually stretches the stud. As the stud is stretched the nut lifts off the flange. The nut is then turned by hand using the supplied spanner ring. Once the nut is tight against the flange, the pressure in the tensioner is released. The hardware is now clamping the flange together.

4.1 Machine Preparation

The flange to be tensioned must be fully closed prior to positioning of studs in the flanges. Turning the rotor shafts is not required, but may be useful. Also, it will be advantageous to remove as many obstructions as possible from the flange area, such as speed probes, shipping plates, and conduit.

4.2 Hardware – Balance

The studs are supplied in component balanced sets. A stud can be exchanged with another in its set without affected the overall balance of the equipment. Do not exchange a stud from one set with another stud from a different set. When shipped from Riverhawk, the studs are not assigned to any specific hole in the flange; this is optional and can be done at the installation site. The set size is determined by the relevant GE order drawing (see section 2.0).

The nuts are supplied in component balanced sets. A nut can be exchanged with another in its set without affecting the overall balance of the equipment. Do not exchange a nut from one set with another nut from a different set. When shipped from Riverhawk, the nuts are not assigned to any specific hole in the flange; this is optional and can be done at the installation site. The set size is determined by the relevant GE order drawing (see section 2.0).

A weight balance certification is supplied with each order. Store this certification in an appropriate location as it will be needed for the purchase of replacement equipment.



215 Clinton Road
New Hartford, NY 13413
Tel: +1 315 768 4855
Fax: +1 315 768 4941
Email: info@riverhawk.com

CUSTOMER'S INFORMATION BOX
CONTENTS ARE INDEPENDENT OF RIVERHAWK DOCUMENT CONTROL

GE DRAWING NUMBER	REV
373A4067	

4.3 Tensioner – Care and Handling

When not in use, the tensioner shall be maintained in a clean environment and all caps and plugs for hydraulic openings and fittings must be in place.

When in use, the tensioner shall be protected from sand and grit.

See section 12 for long term storage requirements.

4.4 Hand Tools

Several hand wrenches and micrometers may be required to perform installation and measurement of the studs:

5/8" Wrench	3' to 4' Breaker Bar
3/4" Wrench	10" to 11" Micrometer or Caliper
13/16" Wrench	13" to 14" Micrometer or Caliper
A set of Allen Wrenches	

4.5 Special Tools

Hydraulic Tensioner Kit:	HT-9754 Hydraulic Tensioner, 2-3/4" (reference GE VENDOC 101B0805)
	HT-5573 Hydraulic Tensioner, 2-3/4" Superseded by HT-9754 (reference GE VENDOC 269B8766)
Hydraulic Pump Kit:	AP-6048 Air-Operated Hydraulic Pump (reference GE VENDOC 269B8768)

CAUTION

Riverhawk recommends that the tensioners be returned to Riverhawk for periodic inspections. Replacement of obsolete tensioners is recommended. Functional upgrades are also recommended. The Riverhawk Service Returns Coordinator should be notified 3-6 months prior to a planned outage to schedule an inspection service.

5.0 Hardware Set Preparations



215 Clinton Road
 New Hartford, NY 13413
 Tel: +1 315 768 4855
 Fax: +1 315 768 4941
 Email: info@riverhawk.com

CUSTOMER'S INFORMATION BOX
 CONTENTS ARE INDEPENDENT OF RIVERHAWK DOCUMENT CONTROL

GE DRAWING NUMBER	REV
373A4067	

5.1 Nut Preparation

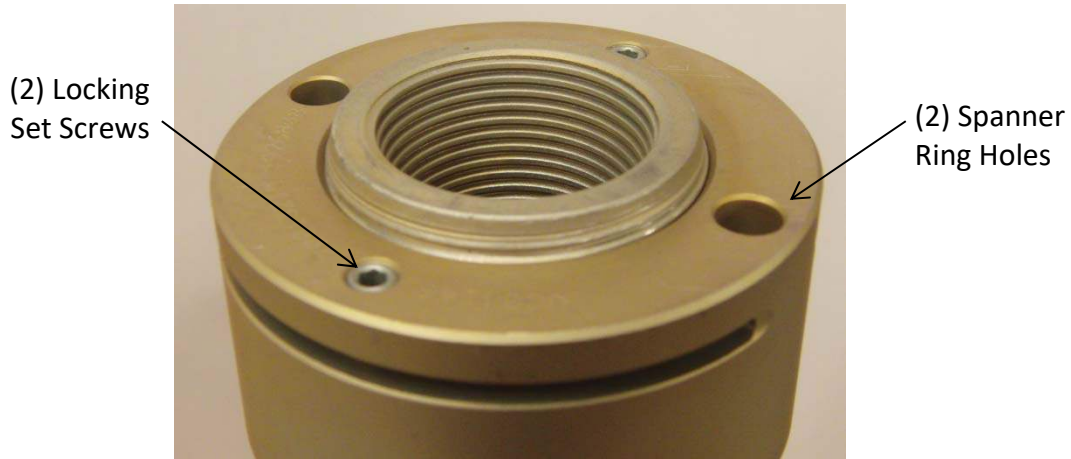

Picture 5A - Riverhawk Locknut

If there is any visible damage on a nut, do not use the part and contact the General Electric or Riverhawk Company for a replacement part. Please be prepared to supply the turbine number, weight certification, and digital photographs for evaluation.

5.1.1 Nut Cleaning - New Installations

For new installations, the nuts should come sealed from the factory and will need no cleaning.

5.1.2 Nut Cleaning - Old Installations

Previously installed nuts require cleaning as follows: Wire brush using a petroleum-based solvent to remove any foreign material on the threads. Clean mating faces with a petroleum-based solvent to remove any foreign material.

5.2 Stud Preparation

Check the stud for any visible damage. If there is any visible damage, do not use the stud and contact the Riverhawk Company for a replacement stud. Please be prepared to supply the turbine number, weight certification, and digital photographs for evaluation.

CAUTION

It is especially important to check the condition of the conical thread used to tension the stud. Thread damage from previous abuse can lead to failure of the stud or tensioning equipment.



215 Clinton Road
 New Hartford, NY 13413
 Tel: +1 315 768 4855
 Fax: +1 315 768 4941
 Email: info@riverhawk.com

CUSTOMER'S INFORMATION BOX
 CONTENTS ARE INDEPENDENT OF RIVERHAWK DOCUMENT CONTROL

GE DRAWING NUMBER	REV
373A4067	

The conical threads of each stud must be clean of grit and dirt before installation or removal. This ensures the proper seating of the puller screw.

5.2.1 Stud Cleaning - New Installations

For new installations, the studs should come sealed from the factory and will need no cleaning.

5.2.2 Stud Cleaning - Old Installations

Previously installed studs may require cleaning. Clean internal conical threads should have a bright and shiny appearance.

If cleaning is required, follow these steps:

1. Blow out the threads with compressed air to remove loose debris and dry conical threads. Do not apply a solvent or other cleaning solution to the threads as this may chemically attack the stud.
2. Use Stud Cleaning Kit, GT-4253 or a similar 1" diameter Brass power brush.



Picture 5B - Brass Power Brush

3. Insert the brush into an electric drill and set drill to run in a counterclockwise direction at high speed.
4. Work the drill in a circular motion while moving the brush in and out to clean all of the threads. Try not to hold the brush in one place too long, so as not to remove the stud's protective coating.
5. Blow out the threads with compressed air to remove loosened debris.
6. Visually inspect threads for cleanliness. Threads should be bright and shiny.
7. Repeat if any dirt can be seen in the threads.
8. Verify threads are clean by using a dental pick to lightly scrape the root of the thread. If additional material comes loose, repeat cleaning process.
9. Inspect threads for any damage that may have been caused by previous installation.



215 Clinton Road
New Hartford, NY 13413
Tel: +1 315 768 4855
Fax: +1 315 768 4941
Email: info@riverhawk.com

CUSTOMER'S INFORMATION BOX
CONTENTS ARE INDEPENDENT OF RIVERHAWK DOCUMENT CONTROL

GE DRAWING NUMBER	REV
373A4067	

Revision H
Page 14 of 45

10. Do **not** apply “Never Seize” to the stud’s threads.
11. Finish the cleaning process by rinsing in a volatile solvent such as acetone and allow the stud to dry.

5.3 Stud Length Measurement

Measure and record the initial lengths of the studs. The following suggestions will improve your results.

- **Plan to start and finish any flange in the same day.**
- **Studs and flange must be at the same temperature.**
- **Number each stud with a marker for later stretch measurement tracking.**
- **Mark the location of measurement on stud end with a permanent marker.**
- **Measure each stud to nearest 0.001 inch (.01 mm).**
- **Record each measurement on the supplied record sheets.**
- **Do not allow the measuring instruments to sit in the sun.**
- **The same person should make all measurements.**

6.0 Stud and Nut Assembly

Refer to the hardware assembly drawing (HF-xxxx) listed in Section 2.0 of the manual.

1. Assemble the cylindrical nut to the internal, conical thread end of the stud.
2. Lubricate the stud’s threads with clean turbine oil or spray lubricant.
3. Lubricate the nut’s threads and nut face with clean turbine oil or spray lubricant.
4. Slide the stud, and nut into the flange as shown in Figures 6A, 6B, and 6C.
5. Install the other nut on the backside.



215 Clinton Road
New Hartford, NY 13413
Tel: +1 315 768 4855
Fax: +1 315 768 4941
Email: info@riverhawk.com

CUSTOMER'S INFORMATION BOX
CONTENTS ARE INDEPENDENT OF RIVERHAWK DOCUMENT CONTROL

GE DRAWING NUMBER	REV
373A4067	

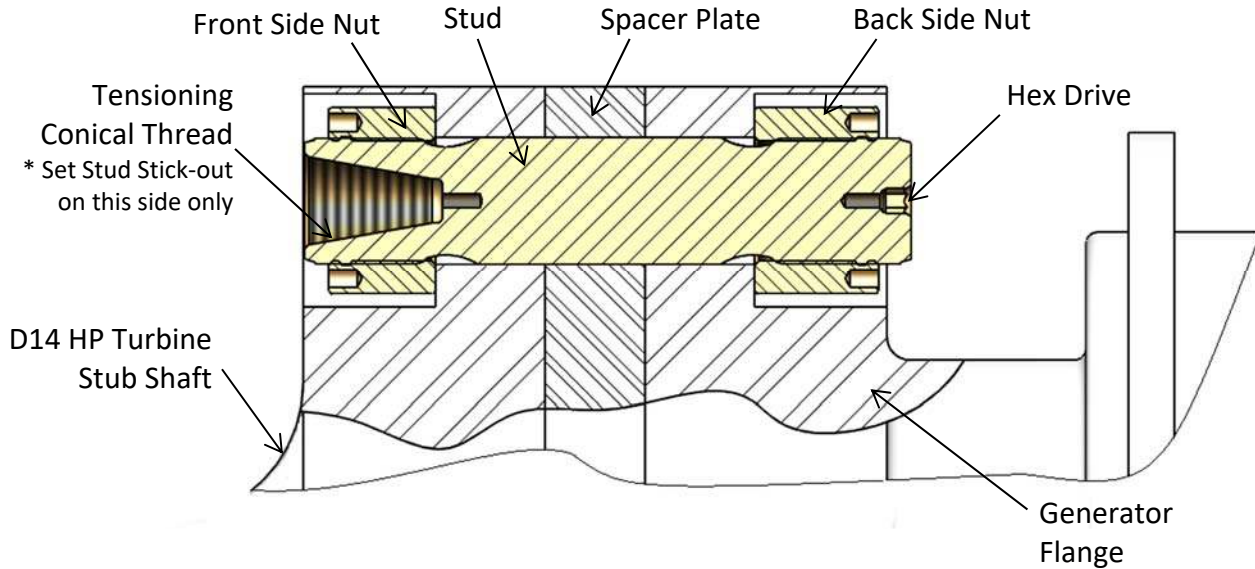

Figure 6A – Cross-section View of HP Stub Shaft to Generator Flange Connection

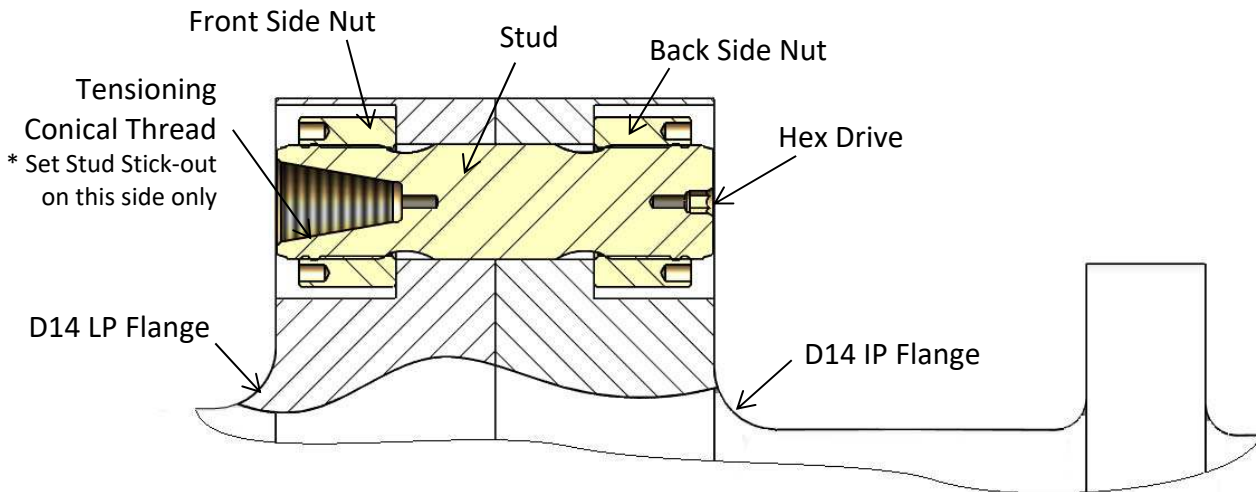

Figure 6B – Cross-section View of D14 LP to IP Flange Connection

CUSTOMER'S INFORMATION BOX
 CONTENTS ARE INDEPENDENT OF RIVERHAWK DOCUMENT CONTROL

GE DRAWING NUMBER	REV
373A4067	



215 Clinton Road
 New Hartford, NY 13413
 Tel: +1 315 768 4855
 Fax: +1 315 768 4941
 Email: info@riverhawk.com

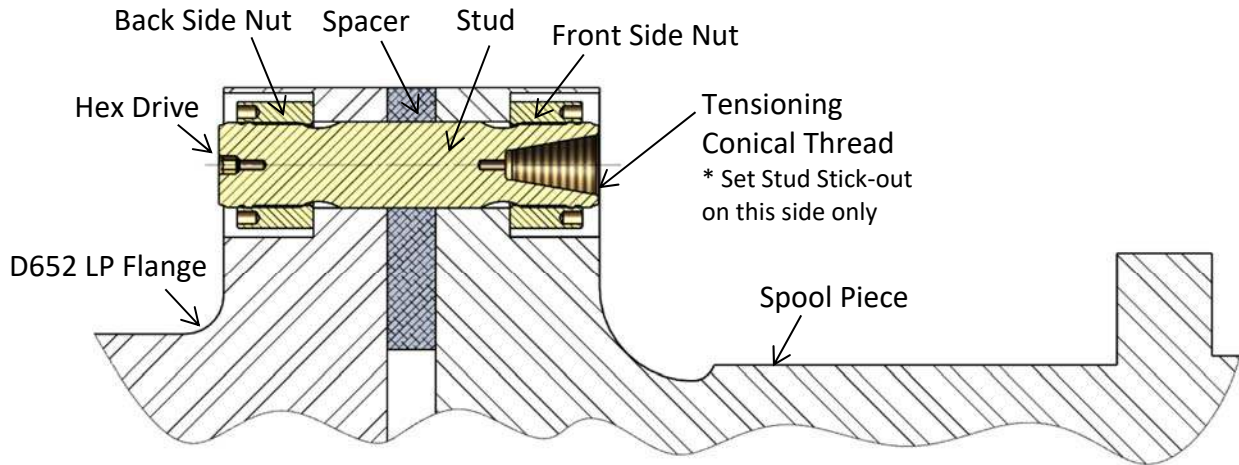

Figure 6C – Cross-section View of D652 LP to Spool Piece Flange Connection

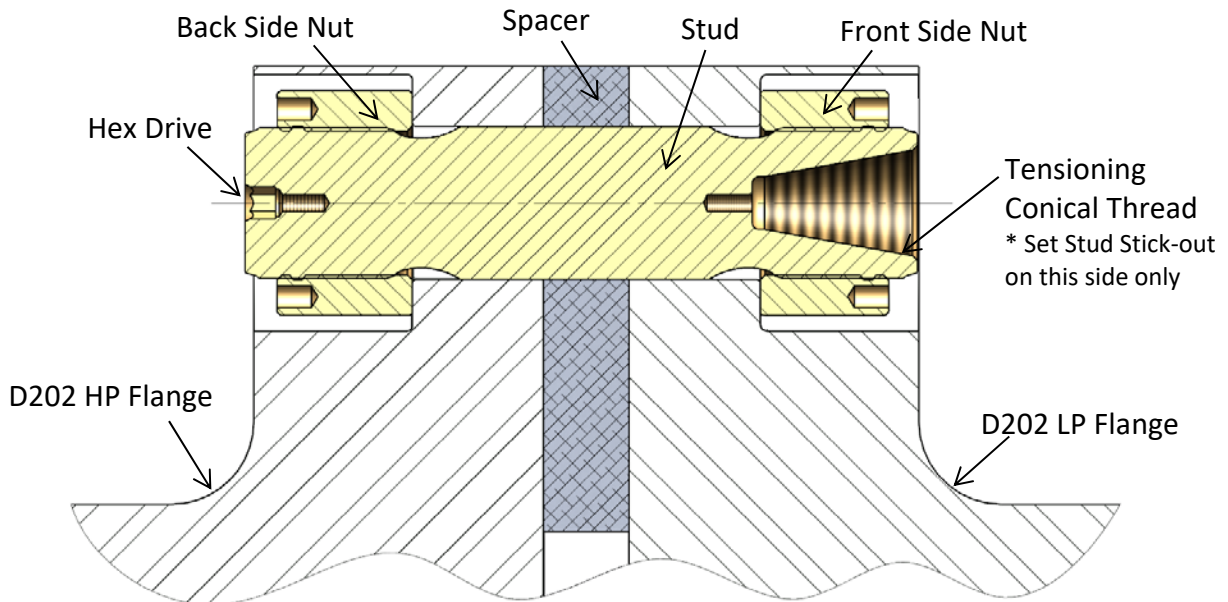

Figure 6D – Cross Section View of D202 HP to LP Flange Connection

CUSTOMER'S INFORMATION BOX
 CONTENTS ARE INDEPENDENT OF RIVERHAWK DOCUMENT CONTROL

GE DRAWING NUMBER	REV
373A4067	



215 Clinton Road
 New Hartford, NY 13413
 Tel: +1 315 768 4855
 Fax: +1 315 768 4941
 Email: info@riverhawk.com



Picture 6E – D14 Gage to measure stick-out



Picture 6F – D652 Gage to measure stick-out



Picture 6G – D202 Gage to measure stick-out



Picture 6H – Use of Drop Gage to measure stick-out

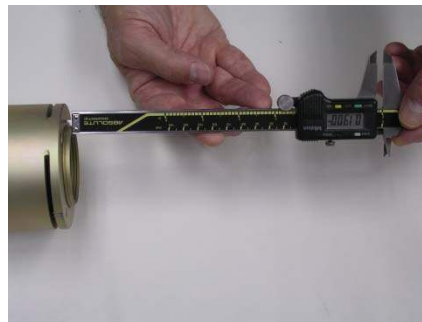

Picture 6J – Use of Calipers to measure stick-out

6. Adjust the nut/stud assembly so that the stud protrudes (or sticks out) from the face of the cylindrical nut the distance specified on the hardware drawing (HF-xxxx). **SETTING THIS PROTRUSION OF STUD TO NUT IS CRITICAL FOR PROPER TENSIONER OPERATION.** A metal stick-out gage is provided with the tensioner to assist the operator in setting the protrusion dimension.

CUSTOMER'S INFORMATION BOX
CONTENTS ARE INDEPENDENT OF RIVERHAWK DOCUMENT CONTROL

GE DRAWING NUMBER	REV
373A4067	



215 Clinton Road
New Hartford, NY 13413
Tel: +1 315 768 4855
Fax: +1 315 768 4941
Email: info@riverhawk.com

7. With Allen wrench in backside of stud, firmly seat backside nut using spanner ring and pin wrench.
8. Recheck the stud stick-out length. If the stick-out length does not match the hardware drawing, adjust the nuts as necessary.
9. Measure and record starting stud installation gage readings.

7.0 Hydraulic Tensioner Equipment Assembly

7.1 Hydraulic Equipment Inspection

7.1.1 Hydraulic Tensioner Inspection

CAUTION

Riverhawk recommends that the tensioner be returned to Riverhawk for periodic inspections. Replacement of obsolete tensioners is recommended. Functional upgrades are also recommended. The Riverhawk Service Returns Coordinator should be notified 3-6 months prior to a planned outage to schedule an inspection service.

This tensioner does not require bleeding. See section 8.3

WARNING

To avoid failure, ensure safety, and proper operation, the tensioner assembly must be installed on a stud in the flange before pressurizing the tensioner. Do not use the tensioner at any pressure unless the tool is installed on a stud in a flange.

Clean puller screw and check for any debris and dents.

Inspect the tensioner guard for any signs of damage including cracked welds. Any guards modified in the field should be replaced. Bent guards should be replaced. Also, be sure the rubber pad is in place on the back side guard, if missing, replace.

Inspect the outside of the tensioner for discoloration patterns that may indicate submersion and internal damage.

Perform an inventory of the loose equipment supplied with the tensioner. An inventory list is provided on the tensioner's technical drawing (Riverhawk HT-xxxx listed in section 2.0 and 4.5). Replacement parts are available from Riverhawk.



215 Clinton Road
New Hartford, NY 13413
Tel: +1 315 768 4855
Fax: +1 315 768 4941
Email: info@riverhawk.com

CUSTOMER'S INFORMATION BOX
CONTENTS ARE INDEPENDENT OF RIVERHAWK DOCUMENT CONTROL

GE DRAWING NUMBER	REV
373A4067	

7.1.1.1 Hydraulic Tensioner's Burst Disc Replacement

The hydraulic tensioner's burst disc is a key element in the overall safe use of the hydraulic tensioner. The burst disc's location is shown on the tensioner's technical drawing (Riverhawk HT-xxxx listed in section 2.0 and 4.5).

Each tensioner is shipped from our factory with one burst disc already installed in the tensioner and with another spare disc for field replacement. Extra burst discs are available from Riverhawk for replacement purposes.

To replace a damaged burst disc:

1. Remove the hydraulic port's dispersion nut, compression ring, and damaged burst disc.
2. Discard the damaged burst disc.
3. Clean the dispersion nut, compression ring, new burst disc, and the hydraulic port with a solvent to ensure a dirt-free installation.
4. Reassemble new burst disc, compression ring, and dispersion nut into the same hydraulic port.

Warning

A damaged burst disc must be replaced with a burst disc of the same design and pressure rating. Do not substitute a damaged burst disc with a different disc type, a different pressure rating, or a foreign object.

7.1.2 Hydraulic Pump Kit Inspection

Refer to the Hydraulic Pump Kit Instruction Manual, IM-293 (GE VENDOC 373A4058). The latest revision may be obtained by contacting Riverhawk Company or thru www.riverhawk.com.

7.2 The 3/8" High Pressure Fitting Assembly

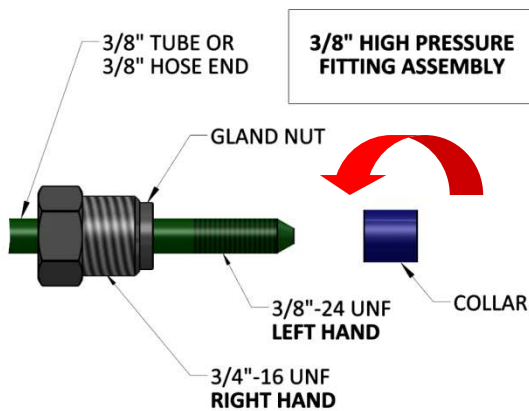

Illustration 1

The Riverhawk hydraulic hose may use a 3/8" High Pressure Fitting to connect to a tensioner. The hose connector is made from a three piece assembly: a gland nut, a collar, and a 3/8" tube or 3/8" hose end. (See Illustration 1)

To assembly the fitting, slide the gland nut over the 3/8" tube or 3/8" hose end. Turn the collar counter-clockwise (**left hand** thread) on to the tube or hose end as shown in Illustration 1.

CUSTOMER'S INFORMATION BOX
CONTENTS ARE INDEPENDENT OF RIVERHAWK DOCUMENT CONTROL

GE DRAWING NUMBER	REV
373A4067	



215 Clinton Road
New Hartford, NY 13413
Tel: +1 315 768 4855
Fax: +1 315 768 4941
Email: info@riverhawk.com

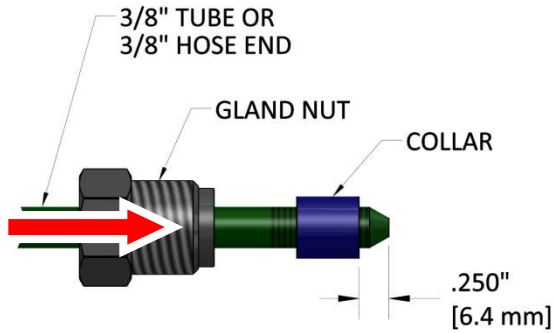

Illustration 2

The collar should be placed .250" (6.4 mm) from the tip of the cone. (See Illustration 2) It may be necessary to adjust this collar with a set of vise-grip pliers. Be careful to not strip the threads off the tube or hose end.

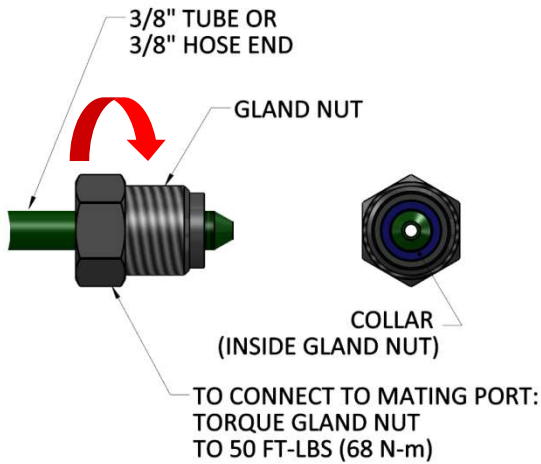

Illustration 3

Slide the gland nut down over the collar. (See Illustration 3) Insert the 3/8" tube or 3/8" hose end into tensioner or hydraulic pump. While firmly holding the tube or hose end to stop it from rotating, turn the gland nut clockwise (**right hand** thread) and torque the gland nut to 50 FT-LBS (68 N-m).

Tips:

- Make sure all parts are clean and free from debris.
- Protect the cone on the end of the 3/8" tube or 3/8" hose end from scratches as this is the sealing surface.
- Replace red plastic caps when finished to protect the threads and cone.

8.0 Assembly of Tensioner on a Stud

The tensioner used in this application can be identified by its ORANGE safety guard. If the tensioner's safety guard is YELLOW, a different set of instructions are required. Consult the Riverhawk factory for assistance.

8.1 Handling of the Tensioner

The tensioner used in this application is designed to require no special lifting instructions. Do not drop any part of the tensioner on the operator or other nearby personnel.

8.2 Kit Assembly

Connect the hydraulic hose from the hydraulic pump to the tensioner.



215 Clinton Road
 New Hartford, NY 13413
 Tel: +1 315 768 4855
 Fax: +1 315 768 4941
 Email: info@riverhawk.com

CUSTOMER'S INFORMATION BOX
 CONTENTS ARE INDEPENDENT OF RIVERHAWK DOCUMENT CONTROL

GE DRAWING NUMBER	REV
373A4067	

Refer to the hardware assembly drawing (HF-xxxx) listed in Section 2.0 of this manual and the tensioner assembly drawing (HT-xxxx) listed in Section 4.5 of this manual to determine how the tensioner must be assembled on the flange for its correct operation.

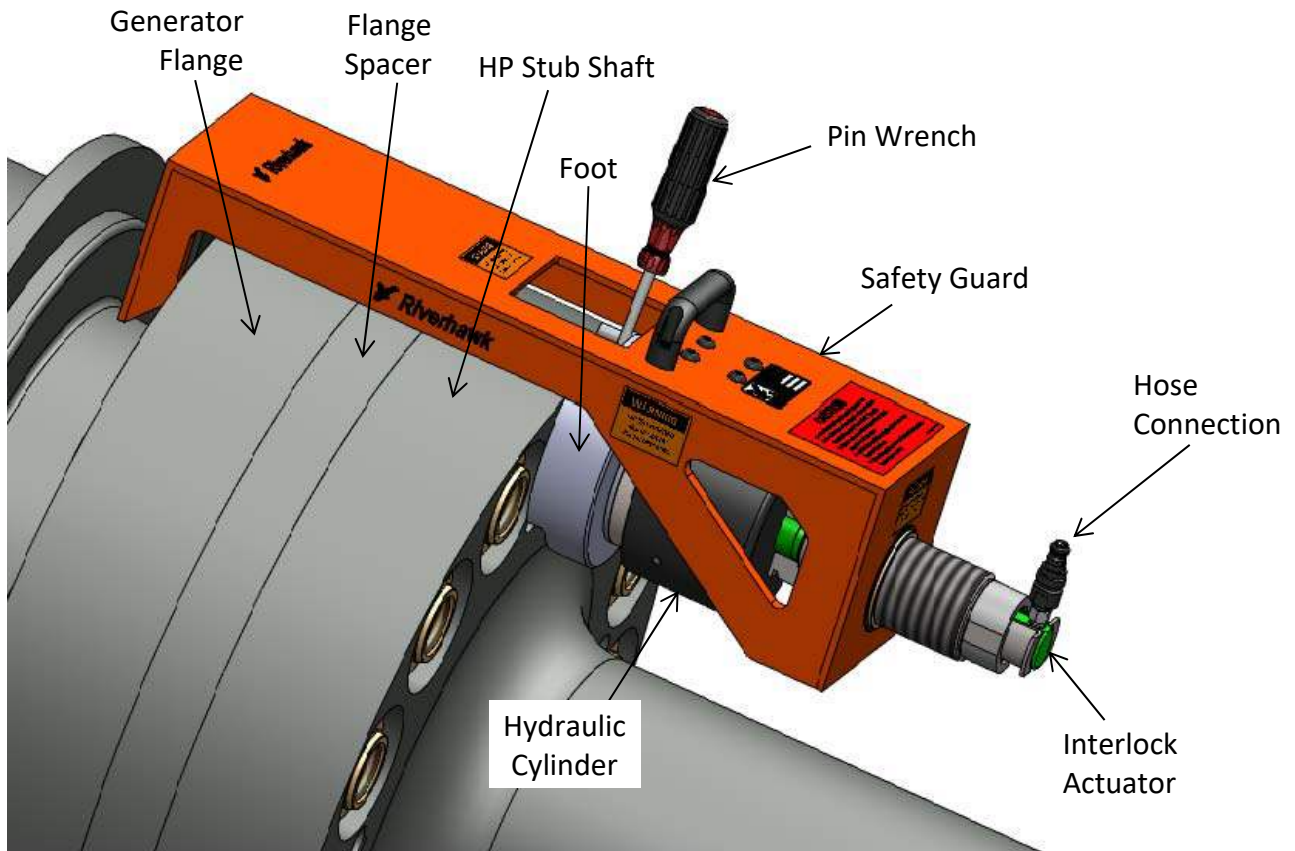

Picture 8A – Features of the Hydraulic Tensioner HT-9754 (formerly HT-5573)



215 Clinton Road
 New Hartford, NY 13413
 Tel: +1 315 768 4855
 Fax: +1 315 768 4941
 Email: info@riverhawk.com

CUSTOMER'S INFORMATION BOX
 CONTENTS ARE INDEPENDENT OF RIVERHAWK DOCUMENT CONTROL

GE DRAWING NUMBER	REV
373A4067	

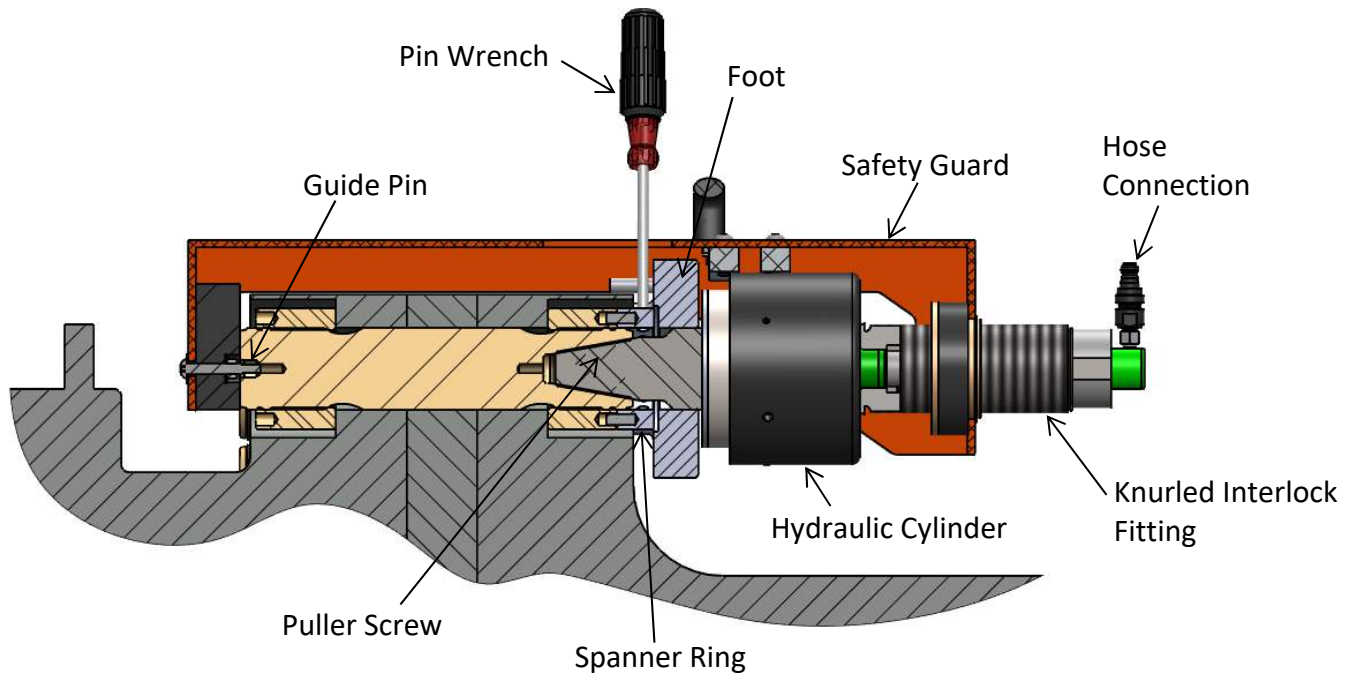

Figure 8B – Cutaway view of Hydraulic Tensioner HT-9754 (formerly HT-5573)

Note: Before threading the puller screw into the stud, carefully check the cleanliness of both the stud's and the puller screw's conical threads. Apply a light coat of clean turbine oil or a spray lubricant to the puller screw. Do not use "Never Seize" on the conical threads. This procedure will ease assembly and assure positive mating of the threads before tightening.

Assembly sequence is as follows:

1. Open the hydraulic return valve on the pump to allow hydraulic fluid to be pushed back from the puller tool into the pump reservoir. (This is automatic on the air-operated hydraulic pump)
2. Place the spanner ring on the nut.
3. Install one puller screw release tape strip into end of the stud. See IM-336 (GE VENDOCS 3734074)
4. Insert the puller screw into the tapered thread of the stud and hand tighten. **Be sure not to cross-thread the puller screw.**



215 Clinton Road
 New Hartford, NY 13413
 Tel: +1 315 768 4855
 Fax: +1 315 768 4941
 Email: info@riverhawk.com

CUSTOMER'S INFORMATION BOX
 CONTENTS ARE INDEPENDENT OF RIVERHAWK DOCUMENT CONTROL

GE DRAWING NUMBER	REV
373A4067	

5. Using an Allen wrench, tighten the puller screw and then back off the puller screw 1/2 a turn. Retighten the puller screw by hand until it is fully inserted. **DO NOT BACK OFF THE PULLER SCREW.**
6. Place the foot over the puller screw and orientate it into position.
7. Thread the tensioner onto the puller screw until it stops. Please note that the internal stop inside the tensioner will cause a gap in between the foot and tensioner. The gap should be 1/16" [1.6mm] to 3/16" [4.8mm]. **DO NOT ATTEMPT TO TIGHTEN THE TENSIONER AGAINST THE FOOT.**
8. Place the guard over the tensioner and position the guide pin into the hole in the backside of the stud.
9. Tighten the knurled interlock fitting by hand until it firmly presses against the tensioner. There should be no gap between the tensioner the interlock fitting.
10. Activate the custom connector from the rear of guard by pushing on the center with your thumb and pulling the tabs with your fore finger and middle finger. Push the assembly forward until it locks into the tensioner. Release fingers from the tabs and then remove thumb, Ensure connection is firmly engaged or else the tensioner will not be connected to the pump.



Picture 8C - Activation of the safety interlock



215 Clinton Road
 New Hartford, NY 13413
 Tel: +1 315 768 4855
 Fax: +1 315 768 4941
 Email: info@riverhawk.com

CUSTOMER'S INFORMATION BOX
 CONTENTS ARE INDEPENDENT OF RIVERHAWK DOCUMENT CONTROL

GE DRAWING NUMBER	REV
373A4067	

11. Connect the hydraulic pump to the tensioner. The tensioner should now be completely assembled and ready for use.

8.3 Bleeding Hydraulic System

Bleeding of the hydraulic system is not necessary with this tensioner design.

9.0 Stud Tensioning

The studs will be tensioned in two steps, at 50% pressure and at final pressure. Follow the tensioning sequence for each flange joint as defined on the record sheets found at the end of this manual.

9.1 Tensioning at 50% pressure

After the tensioner is properly installed apply hydraulic pressure to the tool. Bring the pressure to the 50% level in accordance with the following table.

WARNING

The safety cage must be in place at all times. Keep hands out of designated areas at all times when the tensioner is pressurized otherwise personal injury can occur.

CAUTION

Before threading the puller screw into the stud, carefully check the cleanliness of both the stud's and the puller screw's conical threads. Apply a light coat of clean turbine oil or a spray lubricant to the puller screw. This procedure will ease assembly and assure positive mating of the threads before tightening. Do not use "Never Seize" on the conical threads.

CAUTION

Do not exceed the maximum pressure marked on the tensioner. Excessive pressure can damage the stud and puller screw.

CAUTION

Do not tighten the nut while the tool is coming up to pressure; wait until pressure is achieved before attempting to tighten the nut with the spanner ring. If the tool is not properly installed, the tool could jump off the stud while coming up to pressure.



215 Clinton Road
New Hartford, NY 13413
Tel: +1 315 768 4855
Fax: +1 315 768 4941
Email: info@riverhawk.com

CUSTOMER'S INFORMATION BOX
CONTENTS ARE INDEPENDENT OF RIVERHAWK DOCUMENT CONTROL

GE DRAWING NUMBER	REV
373A4067	

Revision H
Page 25 of 45

<u>Flange Position</u>	<u>Stud Size</u>	<u>50% Pressure</u>	<u>50% Stretch</u>
D14 HP Stub Shaft to Generator Flange	2-3/4" [71 mm]	11000 psi [760 bar]	Do not measure Do not use
D14 LP to D14 IP Flange	2-3/4" [71 mm]	13000 psi [900 bar]	Do not measure Do not use
D652 LP to Spool Piece	2-3/4" [71 mm]	11500 psi [800 bar]	Do not measure Do not use
D202 HP to LP Flange	2-3/4" [71 mm]	11500 psi [800 bar]	Do not measure Do not use

Firmly tighten the cylindrical nuts with approximately 20 ft·lbs [27 N·m] of torque using the pin wrench and spanner ring.

9.2 Removing the Tensioner from an Installed Stud

The tensioner removal is accomplished by the follows steps:

1. Release the hydraulic pressure by either releasing the hand switch on the AP-6048 Pump Kit or by opening the valve on the Manual Pump Kit and leave the valve open.
2. Unscrew the knurled interlock fitting at the end of the guard and remove the guard from the tensioner.
3. Unscrew the tensioner from puller screw.
4. Remove the foot from the puller screw.
5. Unscrew the puller screw using an Allen wrench. Tapping the Allen wrench with a hammer or the use of a 3-4' breaker bar may be necessary to loosen the puller screw. Do not use an impact wrench as this can damage the puller screw.
6. Remove the spanner ring from the nut.
7. Move the tool to the next bolt hole following the tensioning pattern from the stretched record sheets at the end of this manual.



215 Clinton Road
New Hartford, NY 13413
Tel: +1 315 768 4855
Fax: +1 315 768 4941
Email: info@riverhawk.com

CUSTOMER'S INFORMATION BOX
CONTENTS ARE INDEPENDENT OF RIVERHAWK DOCUMENT CONTROL

GE DRAWING NUMBER	REV
373A4067	

9.3 Tensioning at Final Pressure

Repeat the pulling and tightening procedure stated above at full pressure. After all of the studs have been tensioned, measure the final stud length. The final pressure and required stretch values are listed in the following table.

WARNING

The safety cage must be in place at all times. Keep hands out of designated areas at all times when the tensioner is pressurized otherwise personal injury can occur.

CAUTION

Before threading the puller screw into the stud, carefully check the cleanliness of both the stud's and the puller screw's conical threads. Apply a light coat of clean turbine oil or a spray lubricant to the puller screw. This procedure will ease assembly and assure positive mating of the threads before tightening. Do not use "Never Seize" on the conical threads.

CAUTION

Do not exceed the maximum pressure marked on the tensioner. Excessive pressure can damage the stud and puller screw.

CAUTION

Do not tighten the nut while the tool is coming up to pressure; wait until pressure is achieved before attempting to tighten the nut with the spanner ring. If the tool is not properly installed, the tool could jump off the stud while coming up to pressure.

<u>Flange Position</u>	<u>Stud Size</u>	<u>Final Pressure</u>	<u>Final Stretch</u>
D14 HP Stub Shaft to Generator Flange	2-3/4" [71 mm]	22000 psi [1520 bar]	0.020" - 0.023" [0.51 mm - 0.59 mm]
D14 LP to D14 IP Flange	2-3/4" [7mm]	25000 psi [1720 bar]	0.015" - 0.017" [0.38 mm - 0.43 mm]
D652 LP to Spool Piece	2-3/4" [7mm]	23000 psi [1590 bar]	0.019" - 0.022" [0.48 mm - 0.56 mm]
D202 HP to LP Flange	2-3/4" [7mm]	23000 psi [1590 bar]	0.019" - 0.022" [0.48 mm - 0.56 mm]

Firmly tighten the cylindrical nuts with approximately 20 ft·lbs [27 N·m] of torque using the pin wrench and spanner ring.



215 Clinton Road
 New Hartford, NY 13413
 Tel: +1 315 768 4855
 Fax: +1 315 768 4941
 Email: info@riverhawk.com

CUSTOMER'S INFORMATION BOX
 CONTENTS ARE INDEPENDENT OF RIVERHAWK DOCUMENT CONTROL

GE DRAWING NUMBER	REV
373A4067	

Failure to achieve the correct final stretch values will result in an incorrectly tensioned stud.

Incorrect stretch values can be corrected by uninstalling some or all of the selected studs. Re-measure the initial length of the studs and repeat the installation instructions studs. Excessive stretch variations can also be corrected by the same method.

Have final stretch values approved by the supervisor responsible for the installation.

10.0 Nut Thread Locking and Windage Plug Installation

10.1 Nut Thread Locking



Picture 10A - Riverhawk Locknut

Mechanical lock nuts have two set screws located in the top face. Before threading the nut onto the stud, check to be certain the set screws are free to turn. Once the nut is seated torque the set screws to the values specified in the following table. When seated and torqued to the values specified, the load created by the set screw displaces the thread of the nut in the area of the web thereby creating the desired locking action.

Stud Size

2-3/4"
[71 mm]

Set Screw Size

3/8"-24 UN

Torque

200 in·lbs - 250 in·lbs
[22.6 N·m – 28.2 N·m]



215 Clinton Road
New Hartford, NY 13413
Tel: +1 315 768 4855
Fax: +1 315 768 4941
Email: info@riverhawk.com

CUSTOMER'S INFORMATION BOX
CONTENTS ARE INDEPENDENT OF RIVERHAWK DOCUMENT CONTROL

GE DRAWING NUMBER	REV
373A4067	

10.2 Windage Plug Installation

Refer to the hardware assembly drawing (HF-xxxx) listed in Section 2.0 of this manual to determine if windage plugs are required for the installation. Along with other identifying markings, the windage plug's part number can be found on the plug's top surface as shown in the picture below.

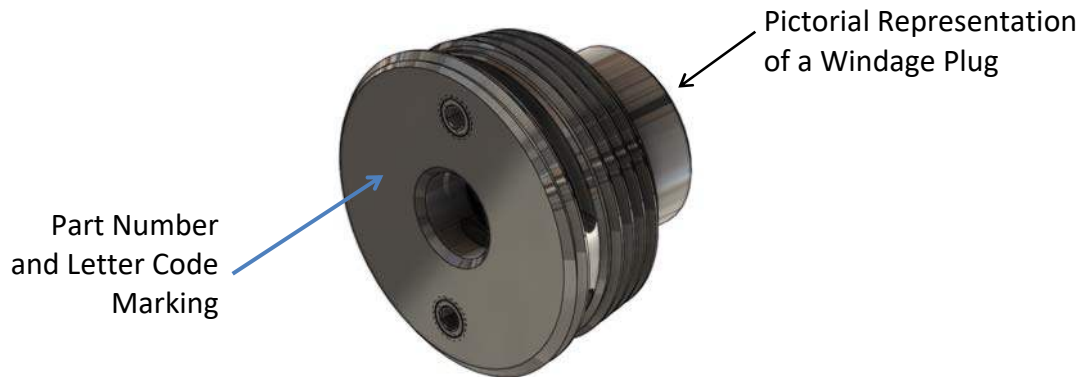

Picture 10B – Windage Plug's Markings

To install the windage plug, use the following instructions:

1. Inspect the stud's conical thread. It should have a bright and shiny appearance. The threads should be visually checked for any damage. Refer to Section 5.2 or Riverhawk Instruction Manual IM-220 (GE Vendoc 373A4025) for assistance.
2. Apply a light coat of clean turbine oil to the stud.

CAUTION

Before installation, carefully check the cleanliness of the windage plug's and the stud's threads. Apply a light coat of clean turbine oil to the stud's conical thread. This procedure will ease assembly before tightening. Do not use "Never Seize" on any surface or thread.



215 Clinton Road
New Hartford, NY 13413
Tel: +1 315 768 4855
Fax: +1 315 768 4941
Email: info@riverhawk.com

CUSTOMER'S INFORMATION BOX
CONTENTS ARE INDEPENDENT OF RIVERHAWK DOCUMENT CONTROL

GE DRAWING NUMBER	REV
373A4067	

Revision H
Page 29 of 45

- Thread the windage plug into the conical thread of the stud. The windage plug must not be cross-threaded when installed. Apply the following torque to seat the windage plug into the stud.

Windage Plug P/N	Installation Torque
7002590	350-450 in-lbs. [39.5-50.8 Nm]
7003292	

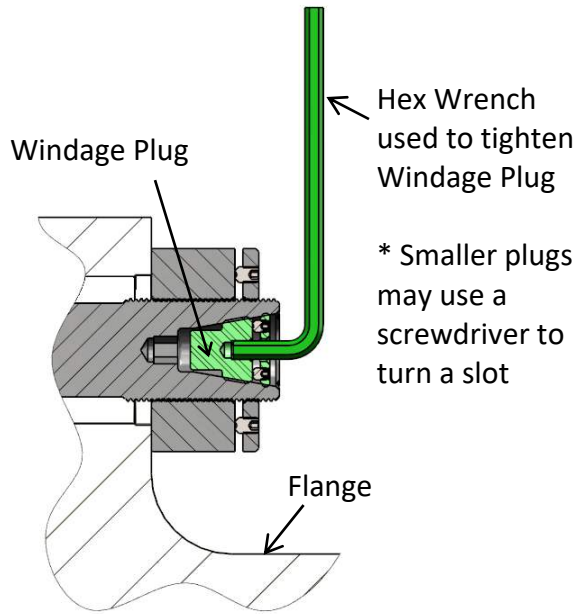

Figure 10C

- The windage plug includes a locking feature similar to the locking feature of the cylindrical nuts. The set screws must be torqued to the following amount. These set screws will cause the top section of the windage plug to lock onto the stud's threads.

Windage Plug P/N	Installation Torque
7002590	80-90 in-lbs. [9.0-10.1 Nm]
7003292	145-155 in-lbs. [16.4-17.5 Nm]

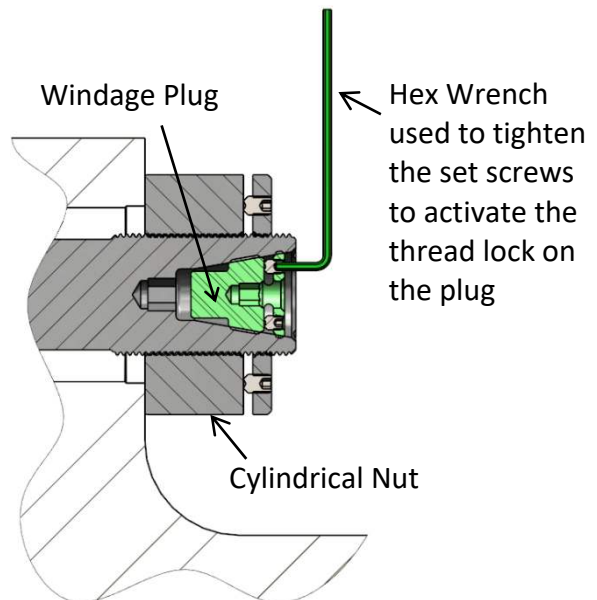

Figure 10D

WARNING

Do not use lock-tite on any of the threads and do not stake any component of this assembly.

- The windage plug should be at least 0.060" [1.5 mm] below the face of the stud for the locking feature to work correctly. If not, loosen set screws and reexamine the stud's and plug's threads for debris or damage. It may be necessary to replace the plug.

CUSTOMER'S INFORMATION BOX
CONTENTS ARE INDEPENDENT OF RIVERHAWK DOCUMENT CONTROL

GE DRAWING NUMBER	REV
373A4067	



215 Clinton Road
New Hartford, NY 13413
Tel: +1 315 768 4855
Fax: +1 315 768 4941
Email: info@riverhawk.com

- The set screws should flush to slightly below the top of the windage plug. The set screw should also press against the slot's opposite surface.

Wrong Installation Position



Partially Loose Set screw

Correct Installation Position



Pressed against Opposite Surface. No Gap.

Picture 10E – Set Screw Position

11.0 Stud and Nut Removal

11.1 Handling of the Tensioner

The tensioner used in this application is designed for no special lifting instructions. Do not drop any part of the tensioner on the operator or other nearby personnel.

11.2 Stud and Nut Removal

WARNING

The safety cage must be in place at all times. Keep hands out of designated areas at all times when the tensioner is pressurized otherwise personal injury can occur.

CAUTION

Before threading the puller screw into the stud, carefully check the cleanliness of both the stud's and the puller screw's conical threads. Apply a light coat of clean turbine oil or a spray lubricant to the puller screw. This procedure will ease assembly and assure positive mating of the threads before tightening. Do not use "Never Seize" on the conical threads.

CAUTION

Do not exceed the maximum pressure marked on the tensioner. Excessive pressure can damage the stud and puller screw.



215 Clinton Road
 New Hartford, NY 13413
 Tel: +1 315 768 4855
 Fax: +1 315 768 4941
 Email: info@riverhawk.com

CUSTOMER'S INFORMATION BOX
 CONTENTS ARE INDEPENDENT OF RIVERHAWK DOCUMENT CONTROL

GE DRAWING NUMBER	REV
373A4067	

CAUTION

Do not tighten the nut while the tool is coming up to pressure; wait until pressure is achieved before attempting to tighten the nut with the spanner ring. If the tool is not properly installed, the tool could jump off the stud while coming up to pressure.

Refer to the hardware assembly drawing (HF-xxxx) listed in Section 2.0 of this manual and the tensioner assembly drawing (HT-xxxx) listed in Section 4.5 of this manual to determine how the tensioner must be assembled on the flange for its correct operation.

Section 8.0 contains diagrams of the tensioner equipment.

Note: Before threading the puller screw into the stud, carefully check the cleanliness of both the stud's and the puller screw's conical threads. Apply a light coat of clean turbine oil or a spray lubricant to the puller screw. Do not use "Never Seize" on the conical threads. This procedure will ease assembly and assure positive mating of the threads before tightening.

Disassembly sequence is as follows:

1. If present, remove the windage plugs from the studs by reversing the installation instructions from section 10.2. It may be necessary to use two Allen wrenches: one to stop the windage plug from rotating, one to remove the set screws. Do not misplace the set screws.
2. Using a wire brush (GT-4253) and shop air, clean the internal tapered thread of the stud to remove any debris/deposits which may have accumulated during service as described in section 5.2.2. Do not continue until ALL debris is removed from the threads.

WARNING

Do not use a hydraulic tensioner to remove a stud with damaged conical threads.

3. With an Allen-wrench loosen the two locking set screws but do not remove from the nut.



215 Clinton Road
New Hartford, NY 13413
Tel: +1 315 768 4855
Fax: +1 315 768 4941
Email: info@riverhawk.com

CUSTOMER'S INFORMATION BOX
CONTENTS ARE INDEPENDENT OF RIVERHAWK DOCUMENT CONTROL

GE DRAWING NUMBER	REV
373A4067	



Picture 11A - Loosening of a nut's set screws

4. Connect the hydraulic hose from the hydraulic pump to the tensioner.
5. Open the hydraulic return valve on the pump to allow hydraulic fluid to be pushed back from the puller tool into the pump reservoir. (This is automatic on the air-operated hydraulic pump)
6. Place the spanner ring on the nut.
7. Insert the puller screw into the tapered thread of the stud and hand tighten. **Be sure not to cross-thread the puller screw.**
8. Using an Allen wrench, tighten the puller screw and then back off the puller screw 1/2 a turn. Retighten the puller screw by hand until it is fully inserted. **DO NOT BACK OFF THE PULLER SCREW.**
9. Place the foot over the puller screw and orientate it into position.
10. Thread the tensioner onto the puller screw until it stops. Please note that the internal stop inside the tensioner will cause a gap in between the foot and tensioner. The gap should be 1/16" [1.6mm] to 3/16" [4.8mm]. **DO NOT ATTEMPT TO TIGHTEN THE TENSIONER AGAINST THE FOOT.**
11. Place the guard over the tensioner and position the guide pin into the hole in the backside of the stud.
12. Tighten the knurled interlock fitting by hand until it firmly presses against the tensioner. There should be no gap between the tensioner the interlock fitting.



215 Clinton Road
New Hartford, NY 13413
Tel: +1 315 768 4855
Fax: +1 315 768 4941
Email: info@riverhawk.com

CUSTOMER'S INFORMATION BOX
CONTENTS ARE INDEPENDENT OF RIVERHAWK DOCUMENT CONTROL

GE DRAWING NUMBER	REV
373A4067	

Revision H
Page 33 of 45

13. Activate the custom connector from the rear of guard by pushing on the center with your thumb and pulling the tabs with your fore finger and middle finger. Push the assembly forward until it locks into the tensioner. Release fingers from the tabs and then remove thumb, ensure connection is firmly engaged or else the tensioner will not be connected to the pump.

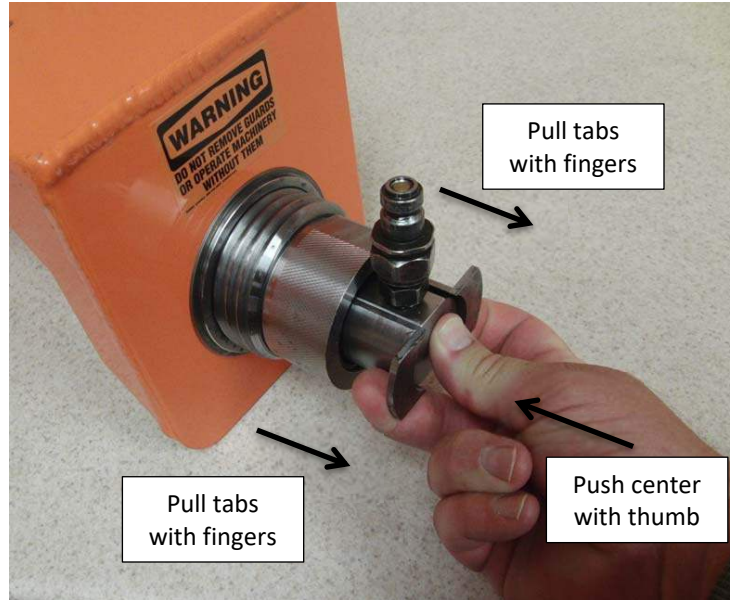

Picture 11B - Activation of the safety interlock

14. Connect the hydraulic pump to the tensioner and apply the appropriate hydraulic pressure per this table.

<u>Flange Position</u>	<u>Stud Size</u>	<u>Final Pressure</u>
D14 HP Stub Shaft to Generator Flange	2-3/4" [71 mm]	22000 psi [1520 bar]
D14 LP to D14 IP Flange	2-3/4" [71 mm]	25000 psi [1720 bar]
D652 LP to Spool Piece	2-3/4" [71 mm]	23000 psi [1590 bar]
D202 HP to LP Flange	2-3/4" [71 mm]	23000 psi [1590 bar]

CUSTOMER'S INFORMATION BOX
CONTENTS ARE INDEPENDENT OF RIVERHAWK DOCUMENT CONTROL

GE DRAWING NUMBER	REV
373A4067	



215 Clinton Road
New Hartford, NY 13413
Tel: +1 315 768 4855
Fax: +1 315 768 4941
Email: info@riverhawk.com

15. Turn the spanner ring with the pin wrench. Loosen and turn the nut approximately 3/4 of a turn.
16. Release the hydraulic pressure.

11.3 Removing the Tensioner from a Stud

The tensioner removal is accomplished by the following steps:

1. Release the hydraulic pressure by either releasing the hand switch on the AP-6048 Pump Kit or by opening the valve on the Manual Pump Kit and leave the valve open.
2. Unscrew the knurled interlock fitting at the end of the guard and remove the guard from the tensioner.
3. Unscrew the tensioner from puller screw.
4. Remove the foot the puller screw.
5. Unscrew the puller screw using an Allen wrench. Tapping the Allen wrench with a hammer or the use of a 3-4' breaker bar may be necessary to loosen the puller screw. Do not use an impact wrench as this can damage the puller screw.
6. Remove the spanner ring from the nut.
7. Move the tool to the next bolt hole following the tensioning pattern from the stretched record sheets at the end of this manual.

12.0 Storage Instructions

Follow these directions to properly store your hydraulic tensioner and hydraulic pump kit for long term storage and shipment.

If any damage is observed, contact the Riverhawk Company to schedule a maintenance inspection.

12.1 Hydraulic Pump Kit Storage

Refer to the Hydraulic Pump Kit Instruction Manual, IM-293 (GE VENDOC 373A4058). The latest revision may be obtained by contacting Riverhawk Company or thru www.riverhawk.com.



215 Clinton Road
New Hartford, NY 13413
Tel: +1 315 768 4855
Fax: +1 315 768 4941
Email: info@riverhawk.com

CUSTOMER'S INFORMATION BOX
CONTENTS ARE INDEPENDENT OF RIVERHAWK DOCUMENT CONTROL

GE DRAWING NUMBER	REV
373A4067	

Revision H
Page 35 of 45

12.2 Hydraulic Tensioner Storage

Check the tensioner for any damage

1. Clean puller screw and check for any debris and dents.
2. Knurled interlock fitting should be clean and free to rotate.
3. Inspect the tensioner guard for any signs of damage. Bent guards must be replaced.

If any damage is observed, contact the Riverhawk Company to schedule a maintenance inspection.

Place the protective plastic cap on the guard's knurled interlock fitting.

Coat the hydraulic tensioner with a light coat of oil and place the tensioner into the original shipping container.

12.3 Store shipping container

Secure the hydraulic pump and hydraulic tensioner into the original shipping containers using the supplied wood braces.

Seal the original shipping container and store under shelter and protected from moisture, sand, and grit.

13.0 Frequently Asked Questions

This section contains some frequently asked questions and problems. If the steps listed here do not solve your problem, contact the Riverhawk Company thru our website, email, or phone call.

Q: Can I rent a hydraulic tensioner kit?

A: Yes, Riverhawk has rental tensioner kits available for most of our hydraulic tensioners.



215 Clinton Road
New Hartford, NY 13413
Tel: +1 315 768 4855
Fax: +1 315 768 4941
Email: info@riverhawk.com

CUSTOMER'S INFORMATION BOX
CONTENTS ARE INDEPENDENT OF RIVERHAWK DOCUMENT CONTROL

GE DRAWING NUMBER	REV
373A4067	

Revision H
Page 36 of 45

Q: A tensioner has pulled itself out of the stud's conical threads. Can I continue using a tensioner on this stud?

A: No. Both the tensioner and the stud may have been damaged and must be removed from the work area. If the stud is tensioned, a Nut Buster repair kit, from Riverhawk, must be used to remove the damaged stud by drilling out the nut. Leaving a damaged stud in place will lead to a safety hazard on future outages.

Riverhawk can supply a replacement stud and nut based on the initial weight certification supplied with the hardware set (see section 4.2). The damaged tensioner should also be returned to Riverhawk for inspection and repair.

If a stud must be left in place, paint the damaged stud with a generous amount of indelible, bright-colored paint. Notify the appropriate GE Safety and Service personnel. Note the location of the damaged stud in the services notes for the machine.

Q: The hydraulic tensioner has been taken up to its final pressure. The final stretch length is short of the final stretch target. What is the next step?

A: Do not increase the hydraulic pressure. Check if the hydraulic pump is set to the right pressure. Install the tensioner and re-pressurize the tensioner to the final pressure then recheck the stretch measurement. If the stretch value is still short, remove the stud from the hole and re-measure the stud's initial length then try to install the stud again.

Q: The hydraulic tensioner has been taken up to its final pressure. The final stretch length is larger than the final stretch target. What is the next step?

A: Remove the stud from the bolt hole. Check if the hydraulic pump is set to the right pressure. Re-measure the stud's initial length then try to install the stud again.

Q: The tensioner is at its final pressure, but the nut cannot be loosened.

A: If the nuts cannot be loosened at the final pressure, continually increasing the pressure will not help and can be dangerous and in some cases make it harder to remove the nut. Check the nut to see if its set screws have been loosened. Check for and remove any corrosion around the nut's threads. Apply penetrating oil between the stud and the nut.



215 Clinton Road
New Hartford, NY 13413
Tel: +1 315 768 4855
Fax: +1 315 768 4941
Email: info@riverhawk.com

CUSTOMER'S INFORMATION BOX
CONTENTS ARE INDEPENDENT OF RIVERHAWK DOCUMENT CONTROL

GE DRAWING NUMBER	REV
373A4067	

Q: How do I clean the conical threads on a stud?

A: The conical threads are best cleaned using a spiral wound brass brush in a drill as described in section 5.2.2

Q: During the initial steps of removing a tensioned stud, the stick-out length is found to be wrong.

A: Do not proceed. Contact Riverhawk for assistance. With the wrong stick-out length, the hydraulic tensioner has a limited stroke and may not work properly and can be damaged.

Q: The hydraulic pump appears to be leaking.

A: Check the hose connection to the hydraulic pump. If the 3/8" high pressure fitting is not assembled correctly as shown in section 7.2, it may look like the pump is leaking. If the problem continues, it may be necessary to open the pump kit. Contact Riverhawk for guidance.

Q: The hydraulic hose has a collar on it that can't be moved by hand

A: The hydraulic fitting is shown in section 7.2. The collar is sometimes held in place with a thread locking compound. This prevents the collar from moving too easily. It may be necessary to adjust this collar with a set of vise-grip pliers. Be careful to not strip the threads off the tube or hose end.



215 Clinton Road
New Hartford, NY 13413
Tel: +1 315 768 4855
Fax: +1 315 768 4941
Email: info@riverhawk.com

CUSTOMER'S INFORMATION BOX
CONTENTS ARE INDEPENDENT OF RIVERHAWK DOCUMENT CONTROL

GE DRAWING NUMBER	REV
373A4067	

14.0 Revision History

Revision Letter	Effective Date	Description
H	Dec 4, 2023	Revised air pressure required for AP-6048 pumps from 80psi [5.5 bar] to 90psi [6.2 bar] in section 3
G	Aug 22, 2022	HT-9754 supersedes HT-5573
F	Apr 6, 2022	Updated EC Declaration of Conformity; Added UKCA Declaration of Conformity
E	Aug 9, 2018	Revised section 10.2
D	Jun 1, 2018	Added 121T9004 to Title page, section 2.1, and section 2.5
C	Feb 23, 2017	Added D202 to Title page; Inserted section 2.4; Inserted figure 6D; Inserted figure 6G; Added D202 to pressure tables in sections 9.1, 9.3, and 11.2
B	Jul 12, 2016	Added D652, 118T5916, 119T9669 to title page; Added Appendix B3; Insert section 2.3; Added 118T5916, 119T9669 to section 2.4; Added puller screw release tape to section 3.0, 8.2; Inserted Figure 6C, Picture 6G in section 6; Added D652 to pressure tables in sections 9.1, 9.3, 11.2
A	Mar 10, 2016	Added GE part numbers to section 2
-	Jun 17, 2014	Released



215 Clinton Road
 New Hartford, NY 13413
 Tel: +1 315 768 4855
 Fax: +1 315 768 4941
 Email: info@riverhawk.com

CUSTOMER'S INFORMATION BOX
 CONTENTS ARE INDEPENDENT OF RIVERHAWK DOCUMENT CONTROL

GE DRAWING NUMBER	REV
373A4067	

Appendix A1

EC Declaration of Conformity

Manufacturer: Riverhawk Company
Address: 215 Clinton Road
New Hartford, NY 13413, USA

The hydraulic pump and bolt tensioning tool described in this manual are used for installing and applying tension to large bolts that are specifically designed by Riverhawk Company to be tensioned hydraulically.

All applicable sections of European Directive 2006/42/EC for machinery have been applied and fulfilled in the design and manufacture of the hydraulic pump and bolt tensioning tool described in this manual. Reference also ISO 12100:2010, ISO 4413:2010, and ISO 4414:2010.

Furthermore, this equipment has been manufactured under the Riverhawk quality system per EN ISO 9001:2015

Consult the Declaration of Conformance included with the shipment of this equipment that identifies the authorized Riverhawk representative, applicable serial numbers, and appropriate signature.



215 Clinton Road
New Hartford, NY 13413
Tel: +1 315 768 4855
Fax: +1 315 768 4941
Email: info@riverhawk.com

CUSTOMER'S INFORMATION BOX
CONTENTS ARE INDEPENDENT OF RIVERHAWK DOCUMENT CONTROL

GE DRAWING NUMBER	REV
373A4067	

Revision H
Page 40 of 45

Appendix A2

UKCA Declaration of Conformity

Manufacturer: Riverhawk Company
Address: 215 Clinton Road
New Hartford, NY 13413, USA

The hydraulic pump and bolt tensioning tool described in this manual are used for installing and applying tension to large bolts that are specifically designed by Riverhawk Company to be tensioned hydraulically.

All applicable sections of Supply of Machinery (Safety) 2008 have been applied and fulfilled in the design and manufacture of the hydraulic pump and bolt tensioning tool described in this manual. Reference also ISO 12100:2010, ISO 4413:2010, and ISO 4414:2010.

Furthermore, this equipment has been manufactured under the Riverhawk quality system per EN ISO 9001:2015

Consult the Declaration of Conformance included with the shipment of this equipment that identifies the authorized Riverhawk representative, applicable serial numbers, and appropriate signature.



215 Clinton Road
New Hartford, NY 13413
Tel: +1 315 768 4855
Fax: +1 315 768 4941
Email: info@riverhawk.com

CUSTOMER'S INFORMATION BOX
CONTENTS ARE INDEPENDENT OF RIVERHAWK DOCUMENT CONTROL

GE DRAWING NUMBER	REV
373A4067	

Appendix B1

STRETCH RECORD SHEET FOR
THE D14 HP STUB SHAFT TO GENERATOR FLANGE

TURBINE NUMBER:

DATE:

TECHNICIAN:

SUPERVISOR:

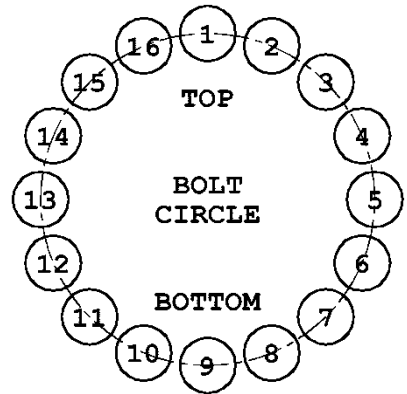

HOLE NUMBER	STARTING MEASUREMENT	FINAL MEASUREMENT	FINAL GAUGE READING
1			
9			
5			
13			
15			
7			
3			
11			
8			
16			
12			
4			
10			
2			
6			
14			

CUSTOMER'S INFORMATION BOX
CONTENTS ARE INDEPENDENT OF RIVERHAWK DOCUMENT CONTROL

GE DRAWING NUMBER	REV
373A4067	



215 Clinton Road
New Hartford, NY 13413
Tel: +1 315 768 4855
Fax: +1 315 768 4941
Email: info@riverhawk.com

Appendix B2

STRETCH RECORD SHEET FOR
THE D14 LP TO D14 IP FLANGE

TURBINE NUMBER:

DATE:

TECHNICIAN:

SUPERVISOR:

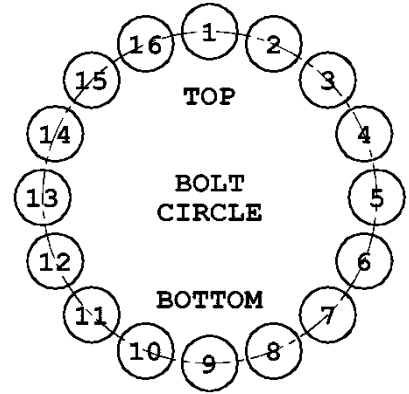

HOLE NUMBER	STARTING MEASUREMENT	FINAL MEASUREMENT	FINAL GAUGE READING
1			
9			
5			
13			
15			
7			
3			
11			
8			
16			
12			
4			
10			
2			
6			
14			

CUSTOMER'S INFORMATION BOX
CONTENTS ARE INDEPENDENT OF RIVERHAWK DOCUMENT CONTROL

GE DRAWING NUMBER	REV
373A4067	



215 Clinton Road
New Hartford, NY 13413
Tel: +1 315 768 4855
Fax: +1 315 768 4941
Email: info@riverhawk.com

Appendix B3

STRETCH RECORD SHEET FOR
THE D652 LP TO SPOOL PIECE FLANGE

TURBINE NUMBER:

DATE:

TECHNICIAN:

SUPERVISOR:

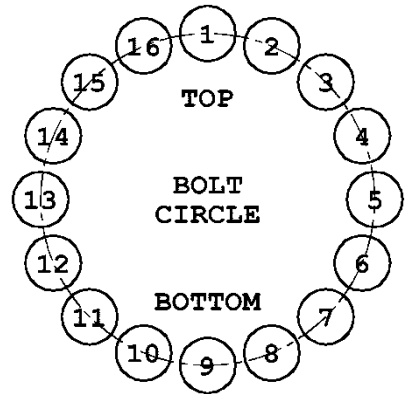

HOLE NUMBER	STARTING MEASUREMENT	FINAL MEASUREMENT	FINAL GAUGE READING
1			
9			
5			
13			
15			
7			
3			
11			
8			
16			
12			
4			
10			
2			
6			
14			

CUSTOMER'S INFORMATION BOX
CONTENTS ARE INDEPENDENT OF RIVERHAWK DOCUMENT CONTROL

GE DRAWING NUMBER	REV
373A4067	



215 Clinton Road
New Hartford, NY 13413
Tel: +1 315 768 4855
Fax: +1 315 768 4941
Email: info@riverhawk.com

Appendix B4

STRETCH RECORD SHEET FOR
THE D202 HP TO LP FLANGE

TURBINE NUMBER:

DATE:

TECHNICIAN:

SUPERVISOR:

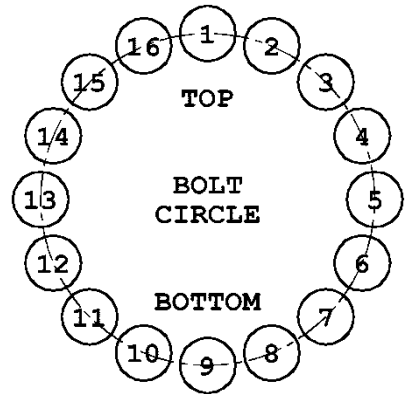

HOLE NUMBER	STARTING MEASUREMENT	FINAL MEASUREMENT	FINAL GAUGE READING
1			
9			
5			
13			
15			
7			
3			
11			
8			
16			
12			
4			
10			
2			
6			
14			

CUSTOMER'S INFORMATION BOX
CONTENTS ARE INDEPENDENT OF RIVERHAWK DOCUMENT CONTROL

GE DRAWING NUMBER	REV
373A4067	



215 Clinton Road
New Hartford, NY 13413
Tel: +1 315 768 4855
Fax: +1 315 768 4941
Email: info@riverhawk.com