



INSTRUCTION MANUAL IM-428

For Frame 7EA Gas Turbine Tensioned Studs and Nuts

Applicable Bolting Connections

Fr. 7EA Gas Turbine - Compressor Section to Turbine Section

Fr. 7EA Gas Turbine - Turbine Section to Load Coupling

Fr. 7EA Gas Turbine - Load Coupling to Generator

The Riverhawk Company reserves the right to update this document without dissemination or notice. The latest revision may be obtained by contacting Riverhawk Company or thru www.riverhawk.com.



Repairs – Rentals
Field Service

215 Clinton Road
New Hartford, NY 13413
Tel: +1 315 768 4855
Fax: +1 315 768 4941
Email: info@riverhawk.com

Rev C
Page 1 of 39

Table of Contents

Section	Description	Page Number
1.0	Cautions and Safety Warnings	3
2.0	Scope and GE Part Number Cross Reference	5
3.0	Quick Checklist	5
4.0	General Preparations	9
5.0	Hardware Set Preparations	11
6.0	Stud and Nut Assembly	13
7.0	Hydraulic Tensioner Equipment Assembly	16
8.0	Assembly of Tensioner on Stud	19
9.0	Stud Tensioning	23
10.0	Thread Locking	26
11.0	Stud and Nut Removal	27
12.0	Storage Instructions	31
13.0	Frequently Asked Questions	32
14.0	Revision History	34
Appendix A1	EC Declaration of Conformity	35
Appendix A2	UKCA Declaration of Conformity	36
Appendix B1	12-Bolt Tensioning Pattern (Compressor Section to Turbine Section) Record Sheet	37
Appendix B2	12-Bolt Tensioning Pattern (GT-LC) Record Sheet	38
Appendix B3	18-Bolt Tensioning Pattern (LC-GEN) Record Sheet	39



215 Clinton Road
 New Hartford, NY 13413
 Tel: +1 315 768 4855
 Fax: +1 315 768 4941
 Email: info@riverhawk.com

1.0 Cautions and Safety Warnings

WARNING

Improper tool use and the failure to follow the correct procedures are the primary root causes of tool failures and personal injuries. A lack of training or experience can lead to incorrect hardware installation or incorrect tool use. Only trained operators with careful, deliberate actions should use hydraulic tensioners. Contact Riverhawk Company with any training needs.

WARNING

Risk of high-pressure hydraulic fluid injection. Riverhawk tools operate under high pressure. Thoroughly inspect all hoses and connections for damage or leaks prior to using this equipment.

CAUTION

Personal injury and equipment damage can occur if the proper health and safety codes and procedures are not followed. Contact the site's health and safety office to determine all applicable safety rules and regulations.

WARNING

The proper personal protective equipment must be worn at all times. Riverhawk recommends at a minimum, safety glasses, long sleeve shirt, hard hat, heavy work gloves, and steel toe shoes.

CAUTION

It is especially important to check the condition of the conical thread used to tension the stud. Thread damage from previous abuse can lead to failure of the stud or tensioning equipment

CAUTION

Riverhawk recommends that the tensioner should be returned to Riverhawk for periodic inspections. Replacement of obsolete tensioners is recommended. Functional upgrades are also recommended. The Riverhawk Service Returns Coordinator should be notified 3-6 months prior to a planned outage to schedule an inspection service.

WARNING

A damaged burst disc must be replaced with a with a burst disc of the same design and pressure rating. Do not substitute a damaged burst disc with a different disc type, a different pressure rating, or a foreign object.



215 Clinton Road
New Hartford, NY 13413
Tel: +1 315 768 4855
Fax: +1 315 768 4941
Email: info@riverhawk.com

WARNING

To avoid failure, ensure safety, and proper operation, the tensioner assembly must be installed on a stud in the flange before pressurizing the tensioner. Do not use the tensioner at any pressure unless the tool is installed on a stud in a flange.

CAUTION

Do not over stroke the tensioner. Over stroke can cause the piston to lose its seal and leak oil.

CAUTION

Personal injury and equipment damage can occur if the puller screw is not securely engaged with the tapered threads of the stud. Proper engagement is achieved when the puller screw is tight in the stud and the tensioner assembly is free to turn.

WARNING

The safety cage must be in place at all times. When the tensioner is pressurized hands must be kept out of designated areas to avoid any potential for personal injury.

CAUTION

Before threading the puller screw into the stud, carefully check the cleanliness of both the stud's and the puller screw's conical threads. Apply a light coat of clean turbine oil or a spray lubricant to the puller screw. This procedure will ease assembly and assure positive mating of the threads before tightening. Do not use "Never Seize" on the conical threads.

CAUTION

Do not tighten the nut while the tool is coming up to pressure; wait until pressure is achieved before attempting to tighten the nut with the spanner ring. If the tool is not properly installed, the tool could jump off the stud while coming up to pressure.

CAUTION

Do not exceed the maximum pressure marked on the tensioner. Excessive pressure can damage the stud and puller screw.

WARNING

FIRE HAZARD: DO NOT heat when puller assembly is in place. Personal injury or equipment damage may occur. Use of an Oxy-Acetylene torch is not recommended



2.0 Scope

This document describes the procedure to be used to install the stud and nut sets supplied by the Riverhawk Company in the flanges at the Compressor section/Turbine Section, Turbine Section/Load Coupling, and Load Coupling/Generator connections.

The various frame configurations covered in this manual are listed in below. Also listed are the pertinent hardware set drawings (HF-xxxx). These drawings as well as tooling drawings (HT-xxxx) form part of this manual.

Equipment Location	Riverhawk P/N
Compressor Section to Turbine Section	HF-2697
Turbine Section to Load Coupling Load Coupling to Generator	HF-0746

The hydraulic tool used for installation and removal is Riverhawk HT-8254.

3.0 Quick Checklist

The following checklist is intended as a summary of the steps needed to use the Riverhawk-supplied equipment. New personnel or those experienced personnel who have not used the Riverhawk equipment recently are encouraged to read the entire manual.

EQUIPMENT INSPECTION

- Check oil level in hydraulic pump.
- Check air pressure at 80psi [5.5 bar] minimum. (For air-driven pumps)
- Check hydraulic hose for damage.
- Test pump.
- Inspect tensioner for any damage.



215 Clinton Road
 New Hartford, NY 13413
 Tel: +1 315 768 4855
 Fax: +1 315 768 4941
 Email: info@riverhawk.com

NUT AND STUD PREPARATION

- Inspect studs and nuts for any damage.
- Clean the studs and nuts.
- Measure stud lengths. (VERY IMPORTANT)
- For the marriage flange only:** Apply “Never-Seize” to the stud’s straight threads. Do not apply any “Never-Seize” to the stud’s conical thread.
- Install studs and nuts into the flange.
- Set stick-out dimension on the compressor side for the marriage flange and the load coupling flange for the turbine/load coupling and coupling/generator flanges. The stud’s conical thread must be on the same side of the flange where the stud stick-out is set.
- Hand tighten nuts on turbine / generator side of flange.
- Verify stick-out measurement (**VERY IMPORTANT**)

TENSIONING (Bolt Installation)

- Check tensioner drawing for correct parts and part numbers.
- Verify the correct feet are used. The short feet are used the marriage flange. The tall feet are used on the load coupling flanges.
- Apply a light coat of clean turbine oil or spray lubricant to the puller screw. **DO NOT USE “NEVER SEIZE” ON THE CONICAL THREADS.**
- Place the spanner ring on the nut. It should be on the side of the flange that has the stud’s conical thread.
- Insert 3/8” hex Allen wrench into the back side of the stud.
- Hand thread the puller screw into the stud. Then back off puller screw 1/2 a turn.
- Hand tighten the puller screw and leave tight. **DO NOT BACK OFF PULLER SCREW.**



- Slide the tensioner over the puller screw. The tensioner should already have the correct feet installed. The short feet are used the marriage flange. The tall feet are used on the load coupling flanges.
- Thread the puller nut and then back nut off two flats or 120 degrees to allow for stud stretch.
- Tensioner should be free to rotate. If it is tight against flange, remove the tensioner and check the stud stick-out dimension.
- Place the safety guard over the tensioner assembly and tighten the threaded hydraulic interlock knob firmly into tensioner body. Firmly seat with a 1/4" Allen wrench.
- Tighten the guard's thumb screws into tensioner body.
- Do NOT bleed the air out of the tensioner!** The tensioner does not need to have its air bleed out.
- Tension to 50%. Consult manual for correct pressure.
- Use the pin wrench in spanner ring to tighten nut.
- Release pressure, move to next stud in pattern.
- Repeat above steps at final pressure.
- Measure final stud length and record on stretch datasheets. Calculate stretch.
- Torque the nuts' set screws.

DETENSIONING (Stud Removal)

- Loosen nuts' set screws
- Inspect and clean studs' conical threads. **Do not continue until ALL debris is removed from the threads!** See instruction manual IM-220. **Do not try to use the tensioner to remove a damaged stud!**
- Check tensioner drawing for correct parts and part numbers.



- Verify the correct feet are used. The short feet are used the marriage flange. The tall feet are used on the load coupling flanges.
- Apply a light coat of clean turbine oil or spray lubricant to the puller screw. **DO NOT USE "NEVER SEIZE" ON THE CONICAL THREADS.**
- Place the spanner ring on the nut. It should be on the side of the flange that has the stud's conical thread.
- Hand thread the puller screw into the stud. Then back off puller screw 1/2 a turn.
- Hand tighten the puller screw and leave tight. **DO NOT BACK OFF PULLER SCREW.**
- Slide the tensioner over the puller screw. The tensioner should already have the correct feet installed. The short feet are used the marriage flange. The tall feet are used on the load coupling flanges.
- Thread the puller nut and then back nut off two flats or 120 degrees to allow for stud stretch.
- Tensioner should be free to rotate. If it is tight against flange, remove the tensioner and check the stud stick-out dimension.
- Place the safety guard over the tensioner assembly and tighten the threaded hydraulic interlock knob firmly into tensioner body. Firmly seat with a 1/4" Allen wrench.
- Tighten the guard's thumb screws into tensioner body.
- Do NOT bleed the air out of the tensioner!** The tensioner does not need to have its air bleed out.
- Apply final pressure.
- Loosen nut with the spanner ring and pin wrench.
- Move to next stud in pattern



4.0 General Preparations

Read and understand all instructions before installing and tensioning studs.

Operators should be trained or have previous experience using Riverhawk tensioning equipment. Training will minimize the chance of improper use of the equipment.

The hydraulic tooling including the hydraulic hoses should be inspected prior to use. Inspection guidelines are listed in the following sub-sections.

This equipment produces very high hydraulic pressures and very high forces. Operators must exercise caution and wear the appropriate personal protective equipment when handling and operating the hydraulic tooling.

High-pressure oil from the hydraulic pump pressurizes the tensioner which generates a very large force that actually stretches the stud. As the stud is stretched the nut lifts off the flange. The nut is then turned by hand using the supplied spanner ring. Once the nut is tight against the flange, the pressure in the tensioner is released. The hardware is now clamping the flange together.

4.1 Machine Preparation

The flange to be tensioned must be fully closed prior to positioning the studs in the flanges. There must be provisions for turning the shafts of the compressor, turbine, and generator. Also, it will be advantageous to remove as many obstructions as possible from the flange area, such as speed probes and conduit.

4.2 Hardware – Balance

The studs are supplied in component balanced sets. A stud can be exchanged with another in its set without affected the overall balance of the equipment. Do not exchange a stud from one set with another stud from a different set. When shipped from Riverhawk, the studs are not assigned to any specific hole in the load coupling flange; this is optional and can be done at the installation site. The set size is determined by the relevant GE order drawing (see section 2.0).

The nuts are supplied in component balanced sets. A nut can be exchanged with another in its set without affecting the overall balance of the equipment. Do not exchange a nut from one set with another nut from a different set. When shipped from Riverhawk, the nuts are not assigned to any specific hole in the load coupling flange; this is optional and can be done at the installation site. The set size is determined by the relevant GE order drawing (see section 2.0).



215 Clinton Road
New Hartford, NY 13413
Tel: +1 315 768 4855
Fax: +1 315 768 4941
Email: info@riverhawk.com

A weight balance certification is supplied with each order. Store this certification in an appropriate location as it will be needed for the purchase of replacement equipment.

4.3 Tensioner – Care and Handling

When not in use, the tensioner shall be maintained in a clean environment and all caps and plugs for hydraulic openings and fittings must be in place.

Use ISO 32 grade oil.

When in use, the tensioner shall be protected from sand and grit.

See section 12 for long term storage requirements.

4.4 Hand Tools

Several hand wrenches and micrometers will be required to perform installation and measurement of the studs:

5/8" wrench

A set of Allen Wrenches

3' – 4' Breaker Bar

8" to 9" micrometer

4.5 Riverhawk Tools

Hydraulic Tensioner Kits: HT-08254 Hydraulic Tensioner, 2"

Hydraulic Pump Kit: AP-0532 Air-Operated Hydraulic Pump

CAUTION

Riverhawk recommends that the tensioners be returned to Riverhawk for periodic inspections. Replacement of obsolete tensioners is recommended. Functional upgrades are also recommended. The Riverhawk Service Returns Coordinator should be notified 3-6 months prior to a planned outage to schedule an inspection service.



215 Clinton Road
New Hartford, NY 13413
Tel: +1 315 768 4855
Fax: +1 315 768 4941
Email: info@riverhawk.com

5.0 Hardware Set Preparations

5.1 Nut Preparation



Picture 5A – Riverhawk Locknut

If there is any visible damage on a nut, do not use the nut and contact the Riverhawk Company for a replacement nut. Please be prepared to supply the turbine number, weight certification, and digital photographs for evaluation.

5.1.1 Nut Cleaning - New Installations

For new installations, the nuts should come sealed from the factory and will need no cleaning.

Before threading the nut onto the stud, the set screws should be loose and free to turn.

5.1.2 Nut Cleaning - Old Installations

Previously installed nuts require cleaning as follows: Wire brush using a petroleum-based solvent to remove any foreign material on the external surfaces and threads.

Before threading the nut onto the stud, the set screws should be loose and free to turn.

5.2 Stud Preparation

Check the stud for any visible damage. If there is any visible damage, do not use the stud and contact the Riverhawk Company for a replacement stud. Please be prepared to supply the turbine number, weight certification, and digital photographs for evaluation.



215 Clinton Road
New Hartford, NY 13413
Tel: +1 315 768 4855
Fax: +1 315 768 4941
Email: info@riverhawk.com

CAUTION

It is especially important to check the condition of the conical thread used to tension the stud. Thread damage from previous abuse can lead to failure of the stud or tensioning equipment.

The conical threads of each stud must be clean of grit and dirt before installation or removal. This ensures the proper seating of the puller screw.

5.2.1 Stud Cleaning - New Installations

For new installations, the studs should come sealed from the factory and will need no cleaning.

5.2.2 Stud Cleaning - Old Installations

Previously installed studs may require cleaning. Clean conical threads should have a bright and shiny appearance.

If cleaning is required, follow these steps:

1. Blow out the threads with compressed air to remove loose debris and dry conical threads. Do not apply a solvent or other cleaning solution to the threads as this may chemically attack the stud.
2. Use Stud Cleaning Kit, GT-4354 or a similar 1/2" diameter Brass power brush. To avoid cross-contamination issues, use different brushes on stainless and alloy steel studs.



Picture 5B - Brass Power Brush

3. Insert the brush into an electric drill and set drill to run in a counterclockwise direction at high speed.
4. Work the drill in a circular motion while moving the brush in and out to clean all of the threads. Try not to hold the brush in one place too long, so as not to remove the stud's protective coating.
5. Blow out the threads with compressed air to remove loosened debris.
6. Visually inspect threads for cleanliness. Threads should be bright and shiny.



7. Repeat if any dirt can be seen in the threads.
8. Inspect threads for any damage that may have been caused by previous installation.
9. Do **not** apply thread lubricants such as “Never Seize” to the stud’s threads.
10. Finish the cleaning process by rinsing in a volatile solvent such as acetone and allow to dry.

5.3 Stud Length Measurement

Measure and record the initial lengths of the studs. The following suggestions will improve your results.

- **Plan to start and finish any flange in the same day.**
- **Studs and flange must be at the same temperature.**
- **Number each stud with a marker for later stretch measurement tracking.**
- **Mark the location of measurement on stud end with a permanent marker.**
- **Measure each stud to nearest 0.001 inch (.01 mm).**
- **Record each measurement on the supplied record sheets.**
- **Do not allow the measuring instruments to sit in the sun.**
- **The same person should make all measurements.**

6.0 Stud and Nut Assembly

Refer to the hardware assembly drawing (HF-xxxx) listed in Section 2.0 of this manual.

1. Begin by checking the nuts’ set screws. They should have be loose and free to turn.
2. Assemble the cylindrical nut to the internal, conical thread end of the stud.

For the marriage flange only: Apply “Never-Seize” to the stud’s straight threads. Do not apply any “Never-Seize” to the stud’s conical thread.

3. Slide the stud and cylindrical nut assembly into the flange as shown in Figures 6A, 6B, and 6C.



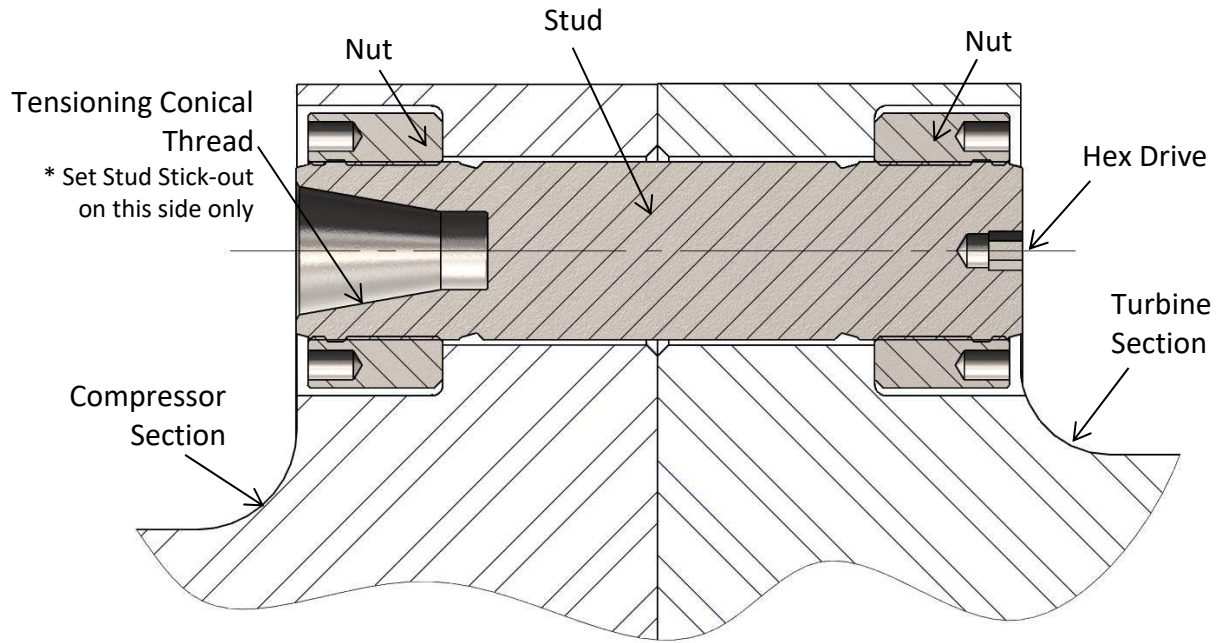

Figure 6A – Cross-section View of Gas Turbine to Mechanical Drive Bolted Flange Connection

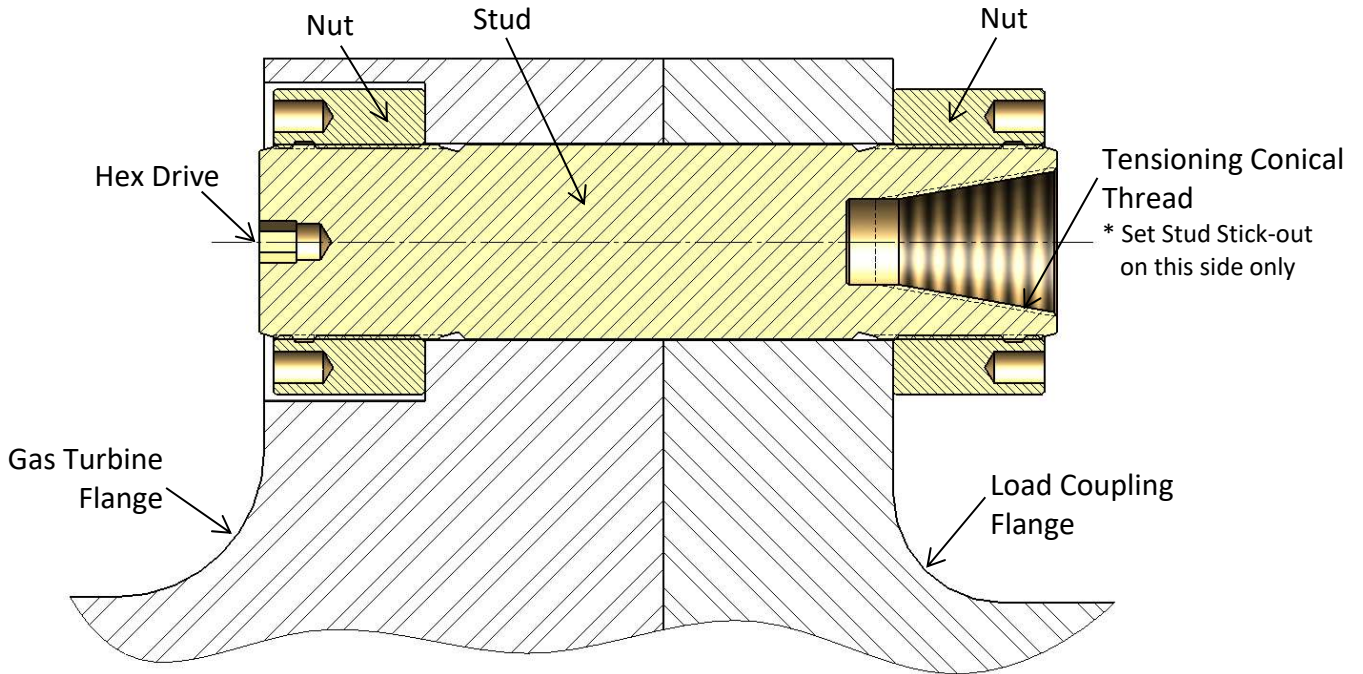

Figure 6B – Cross-section View of Gas Turbine to Load Coupling Bolted Flange Connection

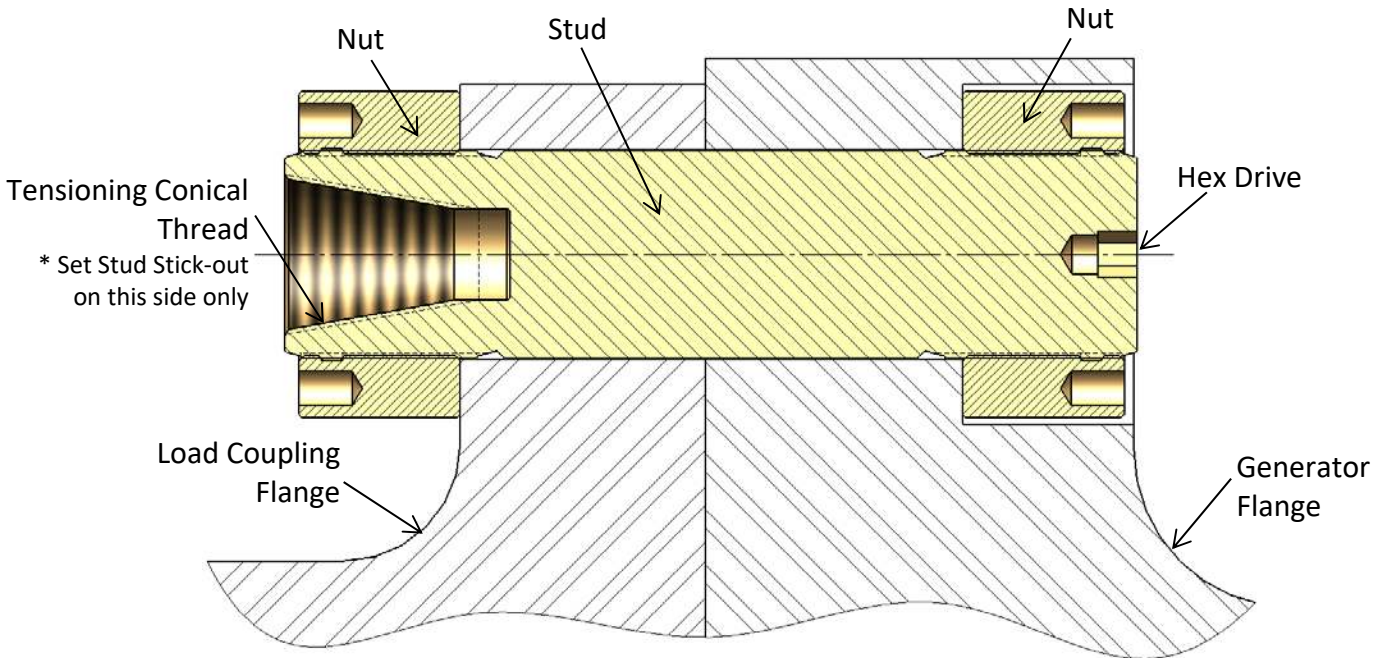

Figure 6C – Cross-section View of Load Coupling to Generator Bolted Flange Connection



- Adjust the nut/stud assembly so that the stud protrudes (or sticks out) from the face of the cylindrical nut the distance specified on the hardware drawing (HF-xxxx). **SETTING THIS PROTRUSION OF STUD TO NUT IS CRITICAL FOR PROPER TENSIONER OPERATION.** A metal stick-out gage maybe provided with the tensioner to assist the operator in setting the protrusion dimension.



Picture 6D – Use of Stick-out Gage

- Install the other nut on the opposite end of the stud.

For the marriage flange only: Apply “Never-Seize” to the stud’s straight threads. Do not apply any “Never-Seize” to the stud’s conical thread.

- Hand tighten the assembly to a snug fit.
- Recheck the stud stick-out length. If the stick-out length does not match the hardware drawing, adjust the nuts as necessary.

7.0 Hydraulic Tensioner Equipment Assembly

7.1 Hydraulic Equipment Inspection



215 Clinton Road
New Hartford, NY 13413
Tel: +1 315 768 4855
Fax: +1 315 768 4941
Email: info@riverhawk.com

7.1.1 Hydraulic Tensioner Inspection

CAUTION

Riverhawk recommends that the tensioner be returned to Riverhawk for periodic inspections. Replacement of obsolete tensioners is recommended. Functional upgrades are also recommended. The Riverhawk Service Returns Coordinator should be notified 3-6 months prior to a planned outage to schedule an inspection service.

Do **not** bleed the air from the hydraulic lines and tensioner at this time. See section 8 for bleeding instructions on when to bleed the air from the hydraulic lines.

WARNING

To avoid failure, ensure safety, and proper operation, the tensioner assembly must be installed on a stud in the flange before pressurizing the tensioner. Do not use the tensioner at any pressure unless the tool is installed on a stud in a flange.

Check puller screw usage life with Riverhawk service bulletin SB-08001.

Clean puller screw and check for any debris and dents.

Puller screw should be free to rotate and move back and forth.

Seam between cylinders closed tightly.

Inspect the tensioner guard for any signs of damage including cracked welds. Any guards modified in the field should be replaced. Bent guards should be replaced.

Inspect the outside of the tensioner for discoloration patterns that may indicate submersion and internal damage.

Perform an inventory of the loose equipment supplied with the tensioner. An inventory list is provided on the tensioner's technical drawing (for example Riverhawk HT-xxxx). Replacement parts are available from Riverhawk.

7.1.1.1 Hydraulic Tensioner's Burst Disc Replacement

The hydraulic tensioner's burst disc is a key element in the overall safe use of the hydraulic tensioner.

Each tensioner is shipped from our factory with one burst disc already installed in the tensioner and with another spare disc for field replacement. Extra burst discs are available from Riverhawk for replacement purposes.



215 Clinton Road
New Hartford, NY 13413
Tel: +1 315 768 4855
Fax: +1 315 768 4941
Email: info@riverhawk.com

To replace a damaged burst disc:

1. Remove the hydraulic port's dispersion nut, compression ring, and damaged burst disc.
2. Discard the damaged burst disc.
3. Clean the dispersion nut, compression ring, new burst disc, and the hydraulic port with a solvent to ensure a dirt-free installation.
4. Reassemble new burst disc, compression ring, and dispersion nut into the same hydraulic port.

Warning

A damaged burst disc must be replaced with a with a burst disc of the same design and pressure rating. Do not substitute a damaged burst disc with a different disc type, a different pressure rating, or a foreign object.

7.1.2 Hydraulic Pump Kit Inspection

Refer to the Hydraulic Pump Kit Instruction Manual, IM-293. The latest revision may be obtained by contacting Riverhawk Company or thru www.riverhawk.com.

7.2 Hydraulic Fittings

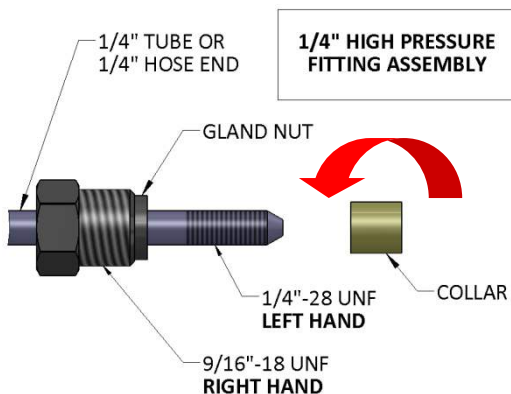

Illustration 1

Riverhawk tensioners use a 1/4" High Pressure port to connect its hydraulic hoses. The hose connector is made from a three piece assembly: a gland nut, a collar, and a 1/4" tube or 1/4" hose end. (See Illustration 1)

To assembly the fitting, slide the gland nut over the 1/4" tube or 1/4" hose end. Turn the collar counter-clockwise (**left hand** thread) on to the tube or hose end as shown in Illustration 1.



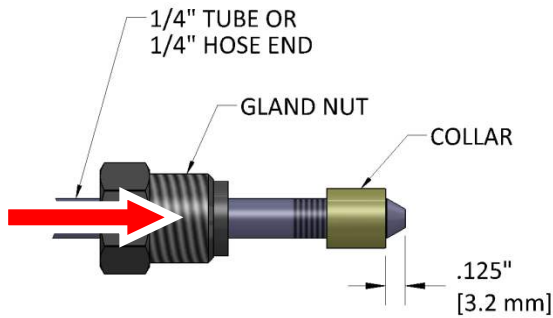

Illustration 2

The collar should be placed .125" (3.2 mm) from the tip of the cone. (See Illustration 2) It may be necessary to adjust this collar with a set of vise-grip pliers. Be careful to not strip the threads off the tube or hose end.

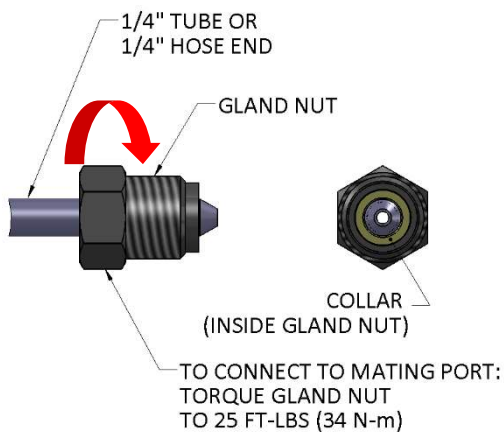

Illustration 3

Slide the gland nut down over the collar. (See Illustration 3) Insert the 1/4" tube or 1/4" hose end into tensioner or hydraulic pump. While firmly holding the tube or hose end to stop it from rotating, turn the gland nut clockwise (**right hand** thread) and torque the gland nut to 25 FT-LBS (34 N-m).

Tips:

- Make sure all parts are clean and free from debris.
- Protect the cone on the end of the 1/4" tube or 1/4" hose end from scratches as this is the sealing surface.
- Replace red plastic caps when finished to protect the threads and cone.

8.0 Assembly of Tensioner on Stud

The tensioner used in this application can be identified by its ORANGE safety guard. If the tensioner's safety guard is YELLOW, a different set of instructions are required. Consult the Riverhawk factory for assistance.

Refer to the hardware assembly drawing (HF-xxxx) listed in Section 2.0 of this manual and the tensioner assembly drawing (HT-xxxx) listed in Section 4.5 of this manual to determine which side of the flange the tensioner must be located on in order to use the tensioner properly.



215 Clinton Road
 New Hartford, NY 13413
 Tel: +1 315 768 4855
 Fax: +1 315 768 4941
 Email: info@riverhawk.com

8.1 Handling of the Tensioner

The tensioner used in this application is designed to require no special lifting instructions. Do not drop any part of the tensioner on the operator or other nearby personnel.

8.2 Tensioner Kit Assembly

This instruction manual covers the use of the hydraulic tensioners listed in Section 4.5.

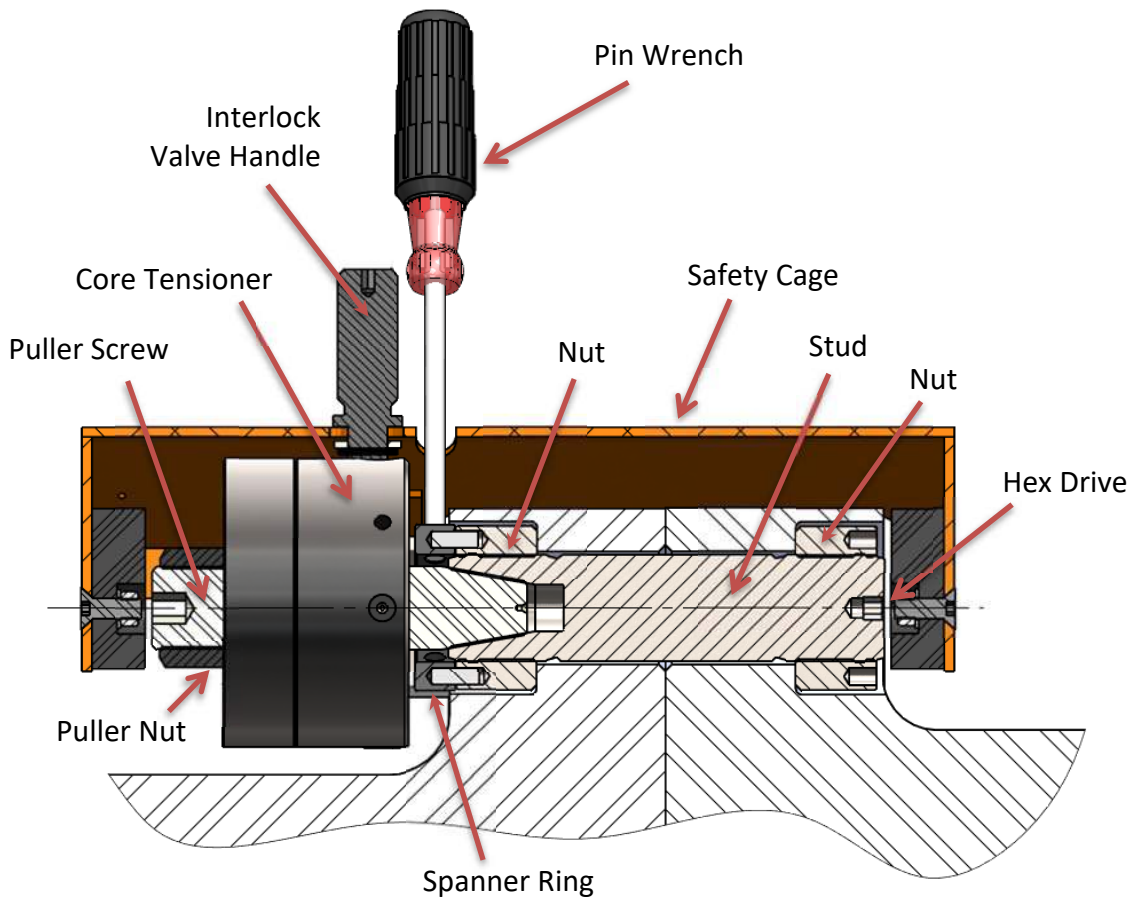

Figure 8A – Cross-section View of HT-8254 on Flange



215 Clinton Road
New Hartford, NY 13413
Tel: +1 315 768 4855
Fax: +1 315 768 4941
Email: info@riverhawk.com

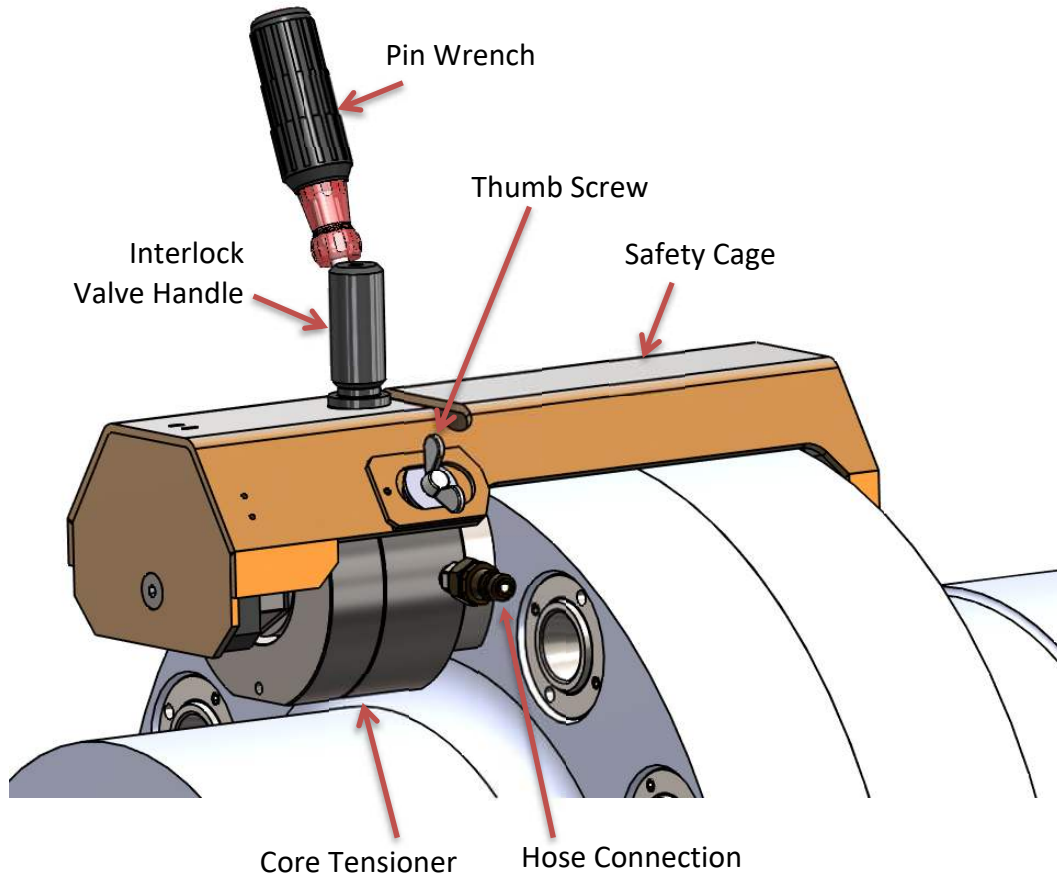

Figure 8B – Cross-section View of HT-8254 Flange



215 Clinton Road
New Hartford, NY 13413
Tel: +1 315 768 4855
Fax: +1 315 768 4941
Email: info@riverhawk.com

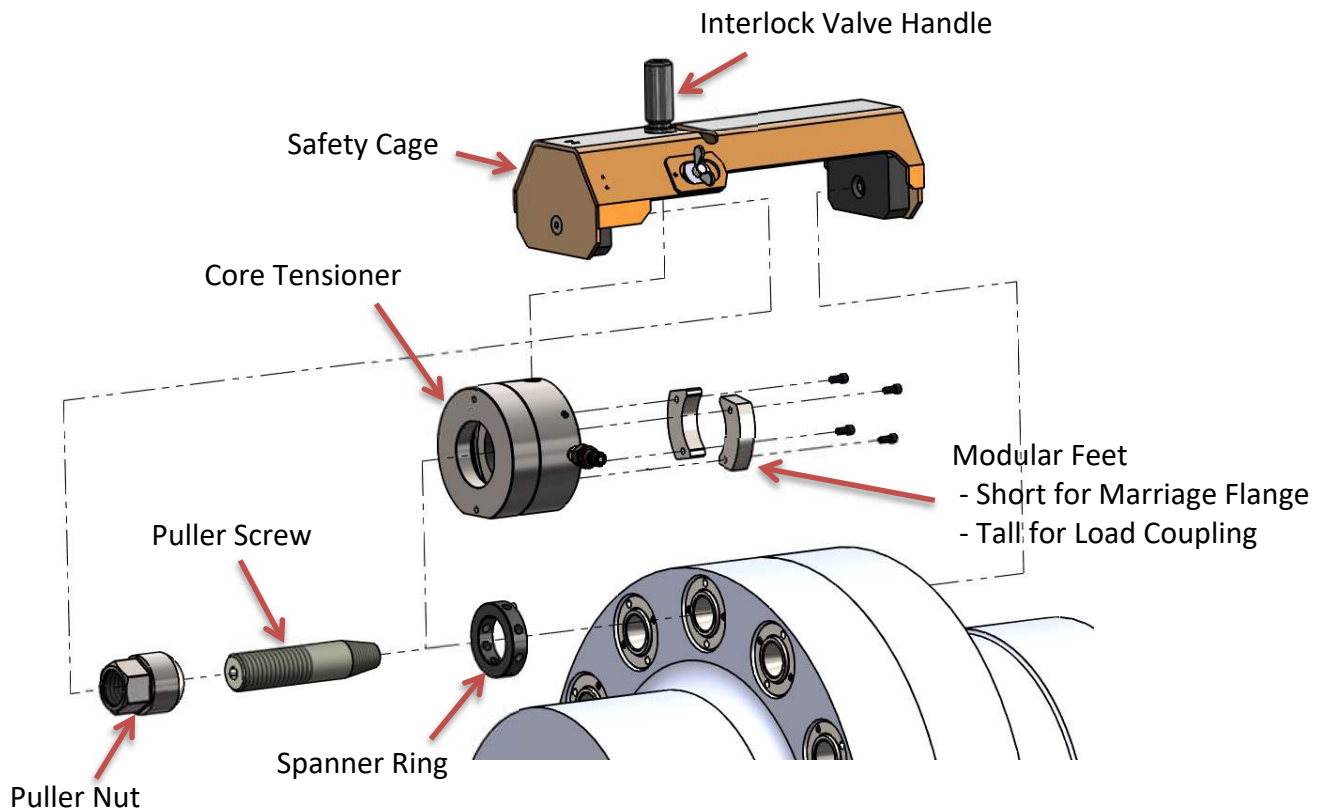

Figure 8C – Cross-section View of HT-8254 on Flange

Assembly sequence is as follows:

1. Open the hydraulic return valve on the pump to allow hydraulic fluid to be pushed back from the puller tool into the pump reservoir. (This is automatic on the air-operated hydraulic pump)
2. Check the tensioner drawing from section 4.5 for the correct parts and part numbers.
3. Check the feet assembled onto the core tensioner. There are two types of feet for this tensioner. When working on a marriage flange, the short feet must be used. When working on the load coupling, the tall feet must be used.
4. Apply a light coat of clean turbine oil or a spray lubricant to the puller screw. Do not use “Never Seize” on the conical threads. Any “Never Seize” on the conical threads may cause the puller screw to disengage from the stud.
5. Place spanner ring on the nut on the side of the flange that has the stud’s conical thread. The spanner ring’s drive pins should be placed into the matching holes in the nut.



215 Clinton Road
 New Hartford, NY 13413
 Tel: +1 315 768 4855
 Fax: +1 315 768 4941
 Email: info@riverhawk.com

6. Insert a 3/8" Allen wrench into the back of the stud to hold it stationary.
7. Hand tighten the puller screw into the stud. Back-off the puller screw 1/2 turn and retighten. **PULLER SCREW MUST BE HAND TIGHT BEFORE TENSIONING. DO NOT OVER TORQUE.**
8. **Be sure not to cross-thread the assembly.**
9. Slide the core tensioner over the puller screw. The tensioner should already have the correct feet installed. The short feet are used on the marriage flange. The tall feet are used on the load coupling.
10. Thread the puller nut and then back nut off two flats or 120 degrees to allow for the stud to stretch.
11. At this point the Tensioner Assembly **MUST BE FREE TO ROTATE** and the puller screw is tight in the stud. If not, recheck the nut and verify the correct stud stick-out length.
12. Place the guard over the tensioner assembly and tighten the threaded hydraulic interlock knob firmly into the tensioner body.
13. Tighten the guard's thumb screws into tensioner body.
14. Place a 1/4" Allen wrench into the end of the threaded hydraulic interlock knob and tighten to firmly seat the hydraulic interlock's O-ring seal.
15. When the pressure is eventually released, allow three minutes for the tensioner's piston to fully retract.

CAUTION

Do not over extend the stud. Over extension can cause the piston to lose its seal and leak oil.

CAUTION

Personal injury and equipment damage can occur if the puller screw is not securely engaged with the tapered threads of the stud. Proper engagement is achieved when the puller screw is tight in the stud and the tensioner assembly is free to turn.

8.3 Bleeding the Hydraulic System

This model tensioner does not need the air bled out of its hydraulic system. Any attempt to bleed the air may inadvertently cause damage to the tool.

9.0 Stud Tensioning

The studs will be tensioned in two steps, at approximately 50% pressure and at final pressure. Follow the tensioning sequence for each flange joint as defined on the data sheets found at the end of this manual.



215 Clinton Road
New Hartford, NY 13413
Tel: +1 315 768 4855
Fax: +1 315 768 4941
Email: info@riverhawk.com

9.1 Tensioning at 50% pressure

After the tensioner is properly installed apply hydraulic pressure to the tool. Bring the pressure to the 50% level in accordance with the following table.

WARNING

The safety cage must be in place at all times. Keep hands out of designated areas at all times when the tensioner is pressurized otherwise personal injury can occur.

CAUTION

Before threading the puller screw into the stud, carefully check the cleanliness of both the stud's and the puller screw's conical threads. Apply a light coat of clean turbine oil or a spray lubricant to the puller screw. This procedure will ease assembly and assure positive mating of the threads before tightening. Do not use "Never Seize" on the conical threads.

CAUTION

Do not exceed the maximum pressure marked on the tensioner. Excessive pressure can damage the stud and puller screw.

CAUTION

Do not tighten the nut while the tool is coming up to pressure; wait until pressure is achieved before attempting to tighten the nut with the spanner ring. If the tool is not properly installed, the tool could jump off the stud while coming up to pressure.

<u>Flange Position</u>	<u>Stud Size</u>	<u>50% Pressure</u>	<u>50% Stretch</u>
Compressor to Turbine	2" [51 mm]	8000 psi [550 bar]	Do not measure Do not use
Turbine to Coupling	2" [51 mm]	9000 psi [620 bar]	Do not measure Do not use
Coupling to Generator	2" [51 mm]	8000 psi [550 bar]	Do not measure Do not use

9.1.1 Tighten nuts

Turn the cylindrical nut using the spanner ring and pin wrench until it bottoms on the flange.



215 Clinton Road
New Hartford, NY 13413
Tel: +1 315 768 4855
Fax: +1 315 768 4941
Email: info@riverhawk.com

9.2 Removing the Tensioner from an Installed Stud

The tensioner removal is to accomplished by the follows steps:

1. Release the tensioner pressure by opening the valve on the pump. Leave valve open. (This is automatic on the air-operated hydraulic pump)
2. Loosen the thumb screws and interlock valve handle. Remove the guard from the assembly.
3. Remove the puller nut from the puller screw.
4. Slide the core tensioner off the puller screw
5. Remove the puller screw. It may be necessary to initially use a break bar to help loosen the puller screw.
6. Remove the spanner ring from the nut.
7. Move the tool to the next stud to be tensioned, following the bolting pattern as defined on the supplied data sheets.

9.3 Tensioning at Final Pressure

Repeat the pulling and tightening procedure stated above at full pressure. After all of the studs have been tensioned, measure the final stud length. The final pressure and required stretch values are listed in the following table.

WARNING

The safety cage must be in place at all times. Keep hands out of designated areas at all times when the tensioner is pressurized otherwise personal injury can occur.

CAUTION

Before threading the puller screw into the stud, carefully check the cleanliness of both the stud's and the puller screw's conical threads. Apply a light coat of clean turbine oil or a spray lubricant to the puller screw. This procedure will ease assembly and assure positive mating of the threads before tightening. Do not use "Never Seize" on the conical threads.

CAUTION

Do not exceed the maximum pressure marked on the tensioner. Excessive pressure can damage the stud and puller screw.

CAUTION

Do not tighten the nut while the tool is coming up to pressure; wait until pressure is achieved before attempting to tighten the nut with the spanner ring. If the tool is not properly installed, the tool could jump off the stud while coming up to pressure.



215 Clinton Road
New Hartford, NY 13413
Tel: +1 315 768 4855
Fax: +1 315 768 4941
Email: info@riverhawk.com

<u>Flange Position</u>	<u>Stud Size</u>	<u>Final Pressure</u>	<u>Final Stretch</u>
Compressor to Turbine	2" [51 mm]	16000 psi [1100 bar]	0.010" - 0.012" [0.25 mm - 0.30 mm]
Turbine to Coupling	2" [51 mm]	19000 psi [1310 bar]	0.013" - 0.015" [0.33 mm - 0.38 mm]
Coupling to Generator	2" [51 mm]	16000 psi [1100 bar]	0.010" - 0.012" [0.25 mm - 0.30 mm]

Excessive stretch variations or low stretch values can be corrected by uninstalling all or selected studs to the pressure values stated in the above table. Have final stretch values approved by the supervisor responsible for the installation.

9.3.1 Tighten nuts

Turn the cylindrical nut using the spanner ring and pin wrench until it bottoms on the flange. Then apply torque to turn the nut an additional 10 degrees. This will aid in achieving the desired stretch.

10.0 Thread Locking

Once pulling and tensioning is completed all stud nuts must be locked in position. Riverhawk hardware employs a reusable mechanical locking device.





Picture 10A - Riverhawk Locknut

Mechanical lock nuts have two set screws located in the top face. During the initial steps of the installation procedure, before the nut was threaded onto the stud, the set screws should have been loosened and free to turn.

After tensioning the stud to its final pressure and the nut on the gas turbine side has been seated, torque the set screws to the values specified in the following table. When seated and torqued to the values specified, the load created by the set screw displaces the thread of the nut in the area of the web creating the desired locking action.

<u>Stud Size</u>	<u>Set Screw Size</u>	<u>Torque</u>
2" [51 mm]	1/4"-28 UN	65in·lbs - 87in·lbs [7.3N·m – 9.8N·m]

11.0 Stud and Nut Removal

11.1 Handling of the Tensioner

The tensioner used in this application is designed for no special lifting instructions. Do not drop any part of the tensioner on the operator or other nearby personnel.



215 Clinton Road
 New Hartford, NY 13413
 Tel: +1 315 768 4855
 Fax: +1 315 768 4941
 Email: info@riverhawk.com

11.2 Stud and Nut Removal

WARNING

Whenever possible, the safety cage should be in place to prevent personal injury. Keep hands out of designated areas at all times when the tensioner is pressurized otherwise personal injury can occur.

CAUTION

Do not exceed the maximum pressure marked on the tensioner. Excessive pressure can damage the stud and puller screw.

CAUTION

Do not tighten the nut while the tool is coming up to pressure; wait until pressure is achieved before attempting to tighten the nut with the spanner ring. If the tool is not properly installed, the tool could jump off the stud while coming up to pressure.

Refer to the hardware assembly drawing (HF-xxxx) listed in Section 2.0 of this manual and the tensioner assembly drawing (HT-xxxx) listed in Section 4.5 of this manual to determine how the tensioner must be assembled on the flexible load coupling for its correct operation.

Section 8.0 contains diagrams of the tensioner equipment.

CAUTION

Before threading the puller screw into the stud, carefully check the cleanliness of both the stud's and the puller screw's conical threads. Apply a light coat of clean turbine oil or a spray lubricant to the puller screw. This procedure will ease assembly and assure positive mating of the threads before tightening. Do not use "Never Seize" on the conical threads.

Disassembly sequence is as follows:

1. Using shop air and a wire brush, such as one supplied with Riverhawk stud cleaning kit GT-4354, clean the internal tapered thread of the stud to remove any debris/deposits which may have accumulated during service as described in section 5.2.2. Do not continue until ALL debris is removed from the threads.

WARNING

Do not use a hydraulic tensioner to remove a stud with damaged conical threads.

2. With an Allen wrench, loosen the nut's two locking set screws but do not remove them from the nut.



215 Clinton Road
New Hartford, NY 13413
Tel: +1 315 768 4855
Fax: +1 315 768 4941
Email: info@riverhawk.com



Picture 11A - Loosening of a nut's set screws

3. Open the hydraulic return valve on the pump to allow hydraulic fluid to be pushed back from the puller tool into the pump reservoir. (This is automatic on the air-operated hydraulic pump)
4. Check the tensioner drawing from section 4.5 for the correct parts and part numbers.
5. Check the feet assembled onto the core tensioner. There are two types of feet for this tensioner. When working on a marriage flange, the short feet must be used. When working on the load coupling, the tall feet must be used.
6. Apply a light coat of clean turbine oil or a spray lubricant to the puller screw. Do not use "Never Seize" on the conical threads. Any "Never Seize" on the conical threads may cause the puller screw to disengage from the stud.
7. Place spanner ring on the nut on the side of the flange that has the stud's conical thread. The spanner ring's drive pins should be placed into the matching holes in the nut.
8. Insert a 3/8" Allen wrench into the back of the stud to hold it stationary.
9. Hand tighten the puller screw into the stud. Back-off the puller screw 1/2 turn and retighten. **PULLER SCREW MUST BE HAND TIGHT BEFORE TENSIONING. DO NOT OVER TORQUE.**
10. **Be sure not to cross-thread the assembly.**
11. Slide the core tensioner over the puller screw. The tensioner should already have the correct feet installed. The short feet are used on the marriage flange. The tall feet are used on the load coupling.
12. Thread the puller nut and then back nut off two flats or 120 degrees to allow for the stud to stretch.



13. At this point the Tensioner Assembly **MUST BE FREE TO ROTATE** and the puller screw is tight in the stud. If not, recheck the nut and verify the correct stud stick-out length.
14. Place the guard over the tensioner assembly and tighten the threaded hydraulic interlock knob firmly into the tensioner body.
15. Place a 1/4" Allen wrench into the end of the threaded hydraulic interlock knob and tighten to firmly seat the hydraulic interlock's O-ring seal.
16. Tighten the guard's thumb screws into tensioner body.

CAUTION

Do not over stroke the tensioner. Over stroke can cause the piston to lose its seal and leak oil.

CAUTION

Personal injury and equipment damage can occur if the puller screw is not securely engaged with the tapered threads of the stud. Proper engagement is achieved when the puller screw is tight in the stud and the tensioner assembly is free to turn.

17. Connect the hydraulic pump to the tensioner and apply the appropriate hydraulic pressure per this table.

<u>Flange Position</u>	<u>Stud Size</u>	<u>Final Pressure</u>
Compressor to Turbine	2" [51 mm]	16000 psi [1100 bar]
Turbine to Coupling	2" [51 mm]	19000 psi [1310 bar]
Coupling to Generator	2" [51 mm]	16000 psi [1100 bar]

18. Turn the spanner ring with the pin wrench. Loosen and turn the nut approximately 3/4 of a turn.
19. Release the hydraulic pressure and allow three minutes for the tensioner's piston to fully retract. Move the tool to the next stud to be removed.

11.3 Removing the Tensioner from a Stud

The tensioner removal is to accomplished by the follows steps:



1. Release the tensioner pressure by opening the valve on the pump. Leave valve open. (This is automatic on the air-operated hydraulic pump)
2. Loosen the thumb screws and interlock valve handle. Remove the guard from the assembly.
3. Remove the puller nut from the puller screw.
4. Slide the core tensioner off the puller screw
5. Remove the puller screw. It may be necessary to initially use a break bar to help loosen the puller screw.
6. Remove the spanner ring from the nut.
7. Move the tool to the next stud to be tensioned, following the bolting pattern as defined on the supplied data sheets.

12.0 Storage Instructions

Follow these directions to properly store your hydraulic tensioner and hydraulic pump kit for long term storage and shipment.

If any damage is observed, contact the Riverhawk Company to schedule a maintenance inspection.

12.1 Hydraulic Pump Kit Storage

Refer to the Hydraulic Pump Kit Instruction Manual, IM-293. The latest revision may be obtained by contacting Riverhawk Company or thru www.riverhawk.com.

12.2 Hydraulic Tensioner Storage

Check the tensioner for any damage.

1. Clean puller screw and check for any debris and dents.
2. Puller screw should be free to rotate and move back and forth.
3. Seam between the cylinder and its end cap is closed tightly.
4. Inspect tensioner guard for any signs of damage. Bent guards should be replaced. Missing rubber pads must be replaced.

If any damage is observed, contact the Riverhawk Company to schedule a maintenance inspection.

Place protective red plastic cap into the hydraulic port.



215 Clinton Road
New Hartford, NY 13413
Tel: +1 315 768 4855
Fax: +1 315 768 4941
Email: info@riverhawk.com

Coat the hydraulic tensioner with a light coat of oil and place the tensioner into the original shipping container.

12.3 Store shipping container

Secure the hydraulic pump and hydraulic tensioner into the original shipping containers using the supplied wood braces.

Seal the original shipping container and store under shelter and protected from moisture, sand, and grit.

13.0 Frequently Asked Questions

This section contains some frequently asked questions and problems. If the steps listed here do not solve your problem, contact the Riverhawk Company thru our website, email, or phone call.

Q: Can I rent a hydraulic tensioner kit?

A: Yes, Riverhawk has rental tensioner kits available for most of our hydraulic tensioners.

Q: A tensioner has pulled itself out of the stud's conical threads. Can I continue using a tensioner on this stud?

A: No. Both the tensioner and the stud may have been damaged and must be removed from the work area. If the stud is tensioned, a Nut Buster repair kit, from Riverhawk, must be used to remove the damaged stud by drilling out the nut. Leaving a damaged stud in place will lead to a safety hazard on future outages.

Riverhawk can supply a replacement stud and nut based on the initial weight certification supplied with the hardware set (see section 4.2). The damaged tensioner should also be returned to Riverhawk for inspection and repair.

If a stud must be left in place, paint the damaged stud with a generous amount of indelible, bright-colored paint. Notify the appropriate GE Safety and Service personnel. Note the location of the damaged stud in the services notes for the machine.



215 Clinton Road
New Hartford, NY 13413
Tel: +1 315 768 4855
Fax: +1 315 768 4941
Email: info@riverhawk.com

Q: The hydraulic tensioner has been taken up to its final pressure. The final stretch length is short of the final stretch target. What is the next step?

A: Do not increase the hydraulic pressure. Check if the hydraulic pump is set to the right pressure. Install the tensioner and re-pressurize the tensioner to the final pressure then recheck the stretch measurement. If the stretch value is still short, remove the stud from the hole and re-measure the stud's initial length then try to install the stud again.

Q: The hydraulic tensioner has been taken up to its final pressure. The final stretch length is larger than the final stretch target. What is the next step?

A: Remove the stud from the bolt hole. Check if the hydraulic pump is set to the right pressure. Re-measure the stud's initial length then try to install the stud again.

Q: Is there an easier way to support or move the tensioner around the coupling shaft?

A: Use two straps. One around the coupling shaft and the other attach to an overhead support. Straps must be slack while installing the tensioner on a stud and while tensioning.

Q: The tensioner is at its final pressure, but the nut cannot be loosened.

A: If the nuts cannot be loosened at the final pressure, continually increasing the pressure will not help and can be dangerous and in some cases make it harder to remove the nut. Check the nut to see if its set screws have been loosened. Check for and remove any corrosion around the nut's threads.

Q: How do I clean the conical threads on a stud?

A: The conical threads are best cleaned using a spiral wound brass brush in a drill as described in section 5.2.2



Q: During the initial steps of removing a tensioned stud, the stick-out length is found to be wrong.

A: Do not proceed. Contact Riverhawk for assistance. With the wrong stick-out length, the hydraulic tensioner has a limited stroke and may not work properly and can be damaged.

Q: The hydraulic pump appears to be leaking.

A: Check the hose connection to the hydraulic pump. If the 1/4" high pressure fitting is not assembled correctly as shown in section 7.2, it may look like the pump is leaking. If the problem continues, it may be necessary to return the pump kit to the Riverhawk factory. Contact Riverhawk for guidance.

Q: The hydraulic hose has a collar on it that can't be moved by hand

A: The hydraulic fitting is shown in section 7.2. The collar is sometimes held in place with a thread locking compound. This prevents the collar from moving too easily. It may be necessary to adjust this collar with a set of vise-grip pliers. Be careful to not strip the threads off the tube or hose end.

Q: Can I rent a hydraulic tensioner kit?

A: Yes, Riverhawk has rental tensioner kits available for most of our hydraulic tensioners.

14.0 Revision History

Revision Letter	Effective Date	Description
C	Jul 21, 2023	Inserted step 14 to section 8.2; Inserted step 15 in section 11.2; revised section 3.0
B	Apr 4, 2022	Updated EC Declaration of Conformity; Added UKCA Declaration of Conformity



215 Clinton Road
 New Hartford, NY 13413
 Tel: +1 315 768 4855
 Fax: +1 315 768 4941
 Email: info@riverhawk.com

Revision Letter	Effective Date	Description
A	Oct 17, 2018	Revised steps 12 and 13 in section 8.2 and steps 14 and 15 in section 11.2
-	Sep 27, 2018	Released

Appendix A1

EC Declaration of Conformity

Manufacturer: Riverhawk Company
 Address: 215 Clinton Road
 New Hartford, NY 13413, USA

The hydraulic pump and bolt tensioning tool described in this manual are used for installing and applying tension to large bolts that are specifically designed by Riverhawk Company to be tensioned hydraulically.

All applicable sections of European Directive 2006/42/EC for machinery have been applied and fulfilled in the design and manufacture of the hydraulic pump and bolt tensioning tool described in this manual. Reference also ISO 12100:2010, ISO 4413:2010, and ISO 4414:2010.

Furthermore, this equipment has been manufactured under the Riverhawk quality system per EN ISO 9001:2015

Consult the Declaration of Conformance included with the shipment of this equipment that identifies the authorized Riverhawk representative, applicable serial numbers, and appropriate signature.



215 Clinton Road
 New Hartford, NY 13413
 Tel: +1 315 768 4855
 Fax: +1 315 768 4941
 Email: info@riverhawk.com

Appendix A2

UKCA Declaration of Conformity

Manufacturer: Riverhawk Company
Address: 215 Clinton Road
New Hartford, NY 13413, USA

The hydraulic pump and bolt tensioning tool described in this manual are used for installing and applying tension to large bolts that are specifically designed by Riverhawk Company to be tensioned hydraulically.

All applicable sections of Supply of Machinery (Safety) 2008 have been applied and fulfilled in the design and manufacture of the hydraulic pump and bolt tensioning tool described in this manual. Reference also ISO 12100:2010, ISO 4413:2010, and ISO 4414:2010.

Furthermore, this equipment has been manufactured under the Riverhawk quality system per EN ISO 9001:2015

Consult the Declaration of Conformance included with the shipment of this equipment that identifies the authorized Riverhawk representative, applicable serial numbers, and appropriate signature.



215 Clinton Road
New Hartford, NY 13413
Tel: +1 315 768 4855
Fax: +1 315 768 4941
Email: info@riverhawk.com

Appendix B1

**STRETCH RECORD SHEET
FOR THE COMPRESSOR TO TURBINE FLANGE**

TURBINE NUMBER:

DATE:

TECHNICIAN:

SUPERVISOR:

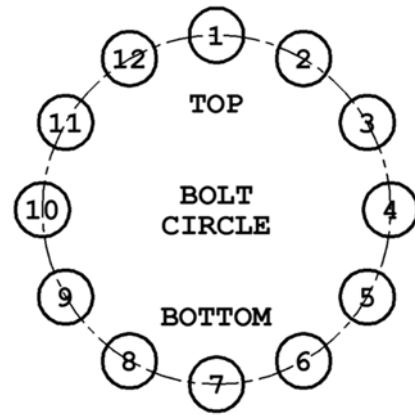

HOLE NUMBER	STARTING LENGTH	FINAL LENGTH	FINAL STRETCH
1			
7			
2			
8			
3			
9			
4			
10			
5			
11			
6			
12			



215 Clinton Road
New Hartford, NY 13413
Tel: +1 315 768 4855
Fax: +1 315 768 4941
Email: info@riverhawk.com

Appendix B2

**STRETCH RECORD SHEET
FOR THE TURBINE TO LOAD COUPLING FLANGE**

TURBINE NUMBER:

DATE:

TECHNICIAN:

SUPERVISOR:

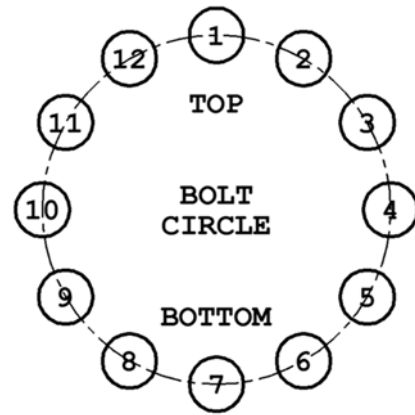

HOLE NUMBER	STARTING LENGTH	FINAL LENGTH	FINAL STRETCH
1			
7			
2			
8			
3			
9			
4			
10			
5			
11			
6			
12			



215 Clinton Road
 New Hartford, NY 13413
 Tel: +1 315 768 4855
 Fax: +1 315 768 4941
 Email: info@riverhawk.com

Appendix B3

**STRETCH RECORD SHEET
FOR THE LOAD COUPLING TO GENERATOR FLANGE**

TURBINE NUMBER:

DATE:

TECHNICIAN:

SUPERVISOR:

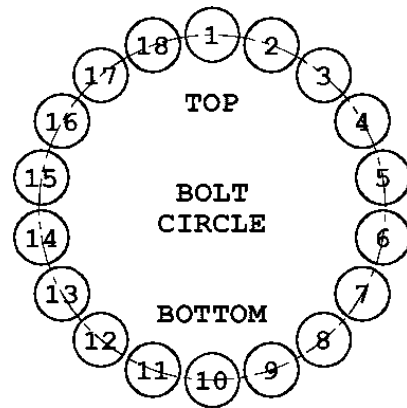

HOLE NUMBER	STARTING LENGTH	FINAL LENGTH	FINAL STRETCH
1			
10			
2			
11			
3			
12			
4			
13			
5			
14			
6			
15			
7			
16			
8			
17			
9			
18			



215 Clinton Road
New Hartford, NY 13413
Tel: +1 315 768 4855
Fax: +1 315 768 4941
Email: info@riverhawk.com