



INSTRUCTION MANUAL IM-364
For Gas Turbine Tensioned
Studs and Nuts

Applicable Bolting Connections

- Fr. 6F.03 Gas Turbine to 6FA Generator
- Fr. 6F.03 Gas Turbine to Load Coupling
- Fr. 6F.03 Gas Turbine Load Coupling to Load Gear
- Fr. 6F.03-FL18 Gas Turbine to 6FA Generator
- Fr. 6F.03-FL18 Gas Turbine to Load Coupling
- Fr. 6F.03-FL18 Gas Turbine Load Coupling to Load Gear
- Fr. 6FA Gas Turbine to 6FA Generator

Applicable GE Ordering Sheet Part Numbers

131T2640P0001	133T8375P0001	381A6850P001	381A6850P021
131T2640P0002	133T8375P0002	381A6850P016	381A6850P022
131T2640P0003	133T8375P0003	381A6850P017	381A6850P025
131T2640P0004	133T8375P0005	381A6850P018	
131T2640P0007	133T8375P0006	381A6850P019	306T4564P0001
131T2640P0008		381A6850P020	306T4564P0002

CUSTOMER'S INFORMATION BOX

CONTENTS ARE INDEPENDENT OF RIVERHAWK DOCUMENT CONTROL

GE Power & Water		GENERAL ELECTRIC COMPANY	
<u>VENDOR SUPPLIED</u>			
GE NOT TO REVISE. GE REVISION LEVEL IS SHOWN ON THIS APPLIQUE. THIS DOCUMENT IS FILED UNDER THE GE DRAWING NUMBER.			
THIS DOCUMENT SHALL BE REVISED IN ITS ENTIRETY. ALL SHEETS OF THIS DOCUMENT ARE THE SAME REVISION LEVEL AS INDICATED IN THIS VENDOR SUPPLIED DRAWING APPLIQUE.			
MLI:		___ OF ___	
GE SIGNATURES	DATE	GE DRAWING NUMBER	REV
CHECKED:		373A4078	
ISSUED:			

The Riverhawk Company reserves the right to update this document without dissemination or notice. The latest revision may be obtained by contacting Riverhawk Company or thru www.riverhawk.com.



Repairs – Rentals
Field Service

215 Clinton Road
New Hartford, NY 13413
Tel: +1 315 768 4855
Fax: +1 315 768 4941
Email: info@riverhawk.com

Table of Contents

Section	Description	Page Number
1.0	Cautions and Safety Warnings	3
2.0	Scope and GE Part Number Cross Reference	4
3.0	Quick Checklist	8
4.0	General Preparations	12
5.0	Hardware Set Preparations	14
6.0	Stud and Nut Assembly	17
7.0	Hydraulic Tensioner Equipment Assembly	19
8.0	Assembly of Tensioner on Stud	21
9.0	Stud Tensioning	24
10.0	Thread Locking the Nut	27
11.0	Stud and Nut Removal	28
12.0	Storage Instructions	31
13.0	Frequently Asked Questions	32
14.0	Revision History	35
Appendix A1	EC Declaration of Conformity	36
Appendix A2	UKCA Declaration of Conformity	37
Appendix B1	Hydraulic Fittings	38
Appendix C1	27-Bolt Tensioning Pattern (GT-LC) Record Sheet	39
Appendix C2	27-Bolt Tensioning Pattern (LC-LG) Record Sheet	40



215 Clinton Road
 New Hartford, NY 13413
 Tel: +1 315 768 4855
 Fax: +1 315 768 4941
 Email: info@riverhawk.com

CUSTOMER'S INFORMATION BOX
 CONTENTS ARE INDEPENDENT OF RIVERHAWK DOCUMENT CONTROL

GE DRAWING NUMBER	REV
373A4078	

1.0 Cautions and Safety Warnings

WARNING

Improper tool use and the failure to follow the correct procedures are the primary root causes of tool failures and personal injuries. A lack of training or experience can lead to incorrect hardware installation or incorrect tool use. Only trained operators with careful, deliberate actions should use hydraulic tensioners. Contact Riverhawk Company with any training needs.

WARNING

Risk of high pressure hydraulic fluid injection. Riverhawk tools operate under high pressure. Thoroughly inspect all hoses and connections for damage or leaks prior to using this equipment.

CAUTION

Personal injury and equipment damage can occur if the proper health and safety codes and procedures are not followed. Contact the site's health and safety office to determine all applicable safety rules and regulations.

WARNING

The proper personal protective equipment must be worn at all times. Riverhawk recommends at a minimum, safety glasses, long sleeve shirt, hard hat, heavy work gloves, and steel toe shoes.

CAUTION

It is especially important to check the condition of the conical thread used to tension the stud. Thread damage from previous abuse can lead to failure of the stud or tensioning equipment

CAUTION

Riverhawk recommends that the tensioner should be returned to Riverhawk for periodic inspections. Replacement of obsolete tensioners is recommended. Functional upgrades are also recommended. Riverhawk should be notified 3-6 months prior to a planned outage to schedule an inspection service.

WARNING

A damaged burst disc must be replaced with a burst disc of the same design and pressure rating. Do not substitute a damaged burst disc with a different disc type, a different pressure rating, or a foreign object.



215 Clinton Road
New Hartford, NY 13413
Tel: +1 315 768 4855
Fax: +1 315 768 4941
Email: info@riverhawk.com

CUSTOMER'S INFORMATION BOX

CONTENTS ARE INDEPENDENT OF RIVERHAWK DOCUMENT CONTROL

GE DRAWING NUMBER	REV
373A4078	

WARNING

To avoid failure, ensure safety, and proper operation, the tensioner assembly must be installed on a stud in the flange before bleeding and pressurizing the tensioner. Do not use the tensioner at any pressure unless the tool is installed on a stud in a flange.

CAUTION

Personal injury and equipment damage can occur if the puller screw is not securely engaged with the tapered threads of the stud. Proper engagement is achieved when the puller screw is tight in the stud and the tensioner assembly is free to turn.

WARNING

The safety cage must be in place at all times. When the tensioner is pressurized hands must be kept out of designated areas to avoid any potential for personal injury.

CAUTION

Before threading the puller screw into the stud, carefully check the cleanliness of both the stud's and the puller screw's conical threads. Apply a light coat of clean turbine oil or a spray lubricant to the puller screw. This procedure will ease assembly and assure positive mating of the threads before tightening. Do not use "Never Seize" on the conical threads.

CAUTION

Do not tighten the nut while the tool is coming up to pressure; wait until pressure is achieved before attempting to tighten the nut with the spanner ring. If the tool is not properly installed, the tool could jump off the stud while coming up to pressure.

CAUTION

Do not exceed the maximum pressure marked on the tensioner. Excessive pressure can damage the stud and the tensioner.

WARNING

FIRE HAZARD: DO NOT apply heat when tensioner is in place. Personal injury or equipment damage may occur. Use of an Oxy-Acetylene torch is not recommended.

WARNING

Do not use a hydraulic tensioner to remove a stud with damaged conical threads.

2.0 Scope and GE Part Number Cross Reference

This document describes the procedure to be used to install the stud and nut sets supplied by the Riverhawk Company in the flanges at the Gas Turbine/Load Coupling and Load



215 Clinton Road
New Hartford, NY 13413
Tel: +1 315 768 4855
Fax: +1 315 768 4941
Email: info@riverhawk.com

CUSTOMER'S INFORMATION BOX
CONTENTS ARE INDEPENDENT OF RIVERHAWK DOCUMENT CONTROL

GE DRAWING NUMBER	REV
373A4078	

Coupling/Gearbox connections. The Load Gear/Generator connection is described by a different manual as listed in the following sections.

The various frame configurations covered in this manual are listed in Sections 2.1 through 2.8 with differences as related to connective hardware defined. Listed also are the pertinent hardware drawings (HF-xxxx). These drawings as well as tooling drawings (HT-xxxx) form part of this manual.

2.1 6F.03 Gas Turbine to 6FA Generator

GE Part Number	Riverhawk P/N	GE VENDOC P/N
133T8375P0001	HF-8730	GE 101B0754

The hydraulic tooling used for installation and removal is Riverhawk HT-6745 (load coupling) and HT-6754 (generator).

This hardware drawing depicts the complete stud and nut package for the Gas Turbine to Load Coupling (1-1/8" size, Qty 27) and Load Coupling to Gearbox (1-1/8" size, Qty 27) as well as the Gearbox to Generator (2" size, Qty 18).

Note: This manual describes HT-6745 tensioner (1-1/8" hardware) **only**.
See manual IM-406 (GE 373A4099) for instructions for HT-6754.

2.2 6F.03 Gas Turbine to Load Coupling

GE Part Number	Riverhawk P/N	GE VENDOC P/N
133T8375P0005	HF-8734	GE 101B0756

The hydraulic tooling used for installation and removal is Riverhawk HT-6745 (load coupling).

This hardware drawing depicts the complete stud and nut package for the Gas Turbine to Load Coupling (1-1/8" size, Qty 27).

2.3 6F.03 Gas Turbine Load Coupling to Load Gear

GE Part Number	Riverhawk P/N	GE VENDOC P/N
133T8375P0006	HF-8735	GE 101B0757

The hydraulic tooling used for installation and removal is Riverhawk HT-6745 (load coupling).



215 Clinton Road
New Hartford, NY 13413
Tel: +1 315 768 4855
Fax: +1 315 768 4941
Email: info@riverhawk.com

CUSTOMER'S INFORMATION BOX
CONTENTS ARE INDEPENDENT OF RIVERHAWK DOCUMENT CONTROL

GE DRAWING NUMBER	REV
373A4078	

This hardware drawing depicts the complete stud and nut package for the Load Coupling to Gearbox (1-1/8" size, Qty 27).

2.4 6F.03-FL18 Gas Turbine to 6FA Generator

GE Part Number	Riverhawk P/N	GE VENDOC P/N
131T2640P0001	HF-8471	GE 101B0745
306T4564P0001	HF-8471	GE 101B0745

The hydraulic tooling used for installation and removal is Riverhawk HT-6745 (load coupling) and HT-6754 (generator).

This hardware drawing depicts the complete stud and nut package for the Gas Turbine to Load Coupling (1-1/8" size, Qty 27) and Load Coupling to Gearbox (1-1/8" size, Qty 27) as well as the Gearbox to Generator (2" size, Qty 18).

Note: This manual describes HT-6745 tensioner (1-1/8" hardware) **only**.
See manual IM-406 (GE 373A4099) for instructions for HT-6754.

2.5 6F.03-FL18 Gas Turbine to Load Coupling

GE Part Number	Riverhawk P/N	GE VENDOC P/N
131T2640P0007	HF-8473	GE 101B0747

The hydraulic tooling used for installation and removal is Riverhawk HT-6745 (load coupling).

This hardware drawing depicts the complete stud and nut package for the Gas Turbine to Load Coupling (1-1/8" size, Qty 27).

2.6 6F.03-FL18 Gas Turbine Load Coupling to Load Gear

GE Part Number	Riverhawk P/N	GE VENDOC P/N
131T2640P0008	HF-8474	GE 101B0748

The hydraulic tooling used for installation and removal is Riverhawk HT-6745 (load coupling).

This hardware drawing depicts the complete stud and nut package for the Load Coupling to Gearbox (1-1/8" size, Qty 27).



215 Clinton Road
New Hartford, NY 13413
Tel: +1 315 768 4855
Fax: +1 315 768 4941
Email: info@riverhawk.com

CUSTOMER'S INFORMATION BOX
CONTENTS ARE INDEPENDENT OF RIVERHAWK DOCUMENT CONTROL

GE DRAWING NUMBER	REV
373A4078	

2.7 6FA Gas Turbine to 6FA Generator

GE Part Number	Riverhawk P/N	GE VENDOC P/N
381A6850P001	HF-0737	GE 359B2521
381A6850P019	HF-0737	GE 359B2521
381A6850P020	HF-0737	GE 359B2521
381A6850P021	HF-8028	GE 101B0717
381A6850P022	HF-8028	GE 101B0717

The hydraulic tooling used for installation and removal is Riverhawk HT-6745 (load coupling) and HT-6754 (generator).

These hardware drawings depict the complete stud and nut package for the Gas Turbine to Load Coupling (1-1/8" size, Qty 27) and Load Coupling to Gearbox (1-1/8" size, Qty 27) as well as the Gearbox to Generator (2" size, Qty 18).

Note: This manual describes HT-6745 tensioner (1-1/8" hardware) **only**.
See manual IM-406 (GE 373A4099) for instructions for HT-6754.

2.8 Hydraulic Tooling

GE Part Number	Riverhawk P/N	GE VENDOC P/N
131T2640P0002	HT-6745	GE 101B0656
	HT-6754	GE 101B0647
	AP-0532	GE 359B2502
131T2640P0003	AP-0532	GE 359B2502
131T2640P0004	HT-6745	GE 101B0656
133T8375P0002	HT-6745	GE 101B0656
	HT-6754	GE 101B0647
	AP-0532	GE 359B2502
133T8375P0003	HT-6745	GE 101B0656
	AP-0532	GE 359B2502
306T4564P0002	HT-6745	GE 101B0656
	HT-6754	GE 101B0647
	AP-0532	GE 359B2502
381A6850P016	HT-6745	GE 101B0656
381A6850P017	HT-6745	GE 101B0656

CUSTOMER'S INFORMATION BOX

CONTENTS ARE INDEPENDENT OF RIVERHAWK DOCUMENT CONTROL

GE DRAWING NUMBER	REV
373A4078	



215 Clinton Road
New Hartford, NY 13413
Tel: +1 315 768 4855
Fax: +1 315 768 4941
Email: info@riverhawk.com

381A6850P018	HT-6745	GE 101B0656
381A6850P019	HT-6745 HT-6754 AP-0532	GE 101B0646 GE 101B0647 GE 359B2502
381A8650P020	HT-6745 HT-6754 AP-0532	GE 101B0646 GE 101B0647 GE 359B2502
381A6850P025	HT-6745	GE 101B0646

Note: Hydraulic tooling list is for all related tooling for the gas turbine to generator connections. This manual describes HT-6745 tensioner (1-1/8" hardware) **only**. See manual IM-406 (GE 373A4099) for instructions to the other tooling listed above.

3.0 Quick Checklist

The following checklist is intended as a summary of the steps needed to use the Riverhawk-supplied equipment. New personnel or those experienced personnel who have not used the Riverhawk equipment recently are encouraged to read the entire manual.

EQUIPMENT INSPECTION

- Check oil level in hydraulic pump.
- Check air pressure at 80psi [5.5 bar] minimum. (For air-driven pumps)
- Check hydraulic hose for damage.
- Test pump.
- Inspect tensioner for any damage.

NUT AND STUD PREPARATION

- Inspect studs and nuts for any damage.



215 Clinton Road
New Hartford, NY 13413
Tel: +1 315 768 4855
Fax: +1 315 768 4941
Email: info@riverhawk.com

CUSTOMER'S INFORMATION BOX
CONTENTS ARE INDEPENDENT OF RIVERHAWK DOCUMENT CONTROL

GE DRAWING NUMBER	REV
373A4078	

- Clean the studs and nuts.
- Measure stud lengths. (VERY IMPORTANT)
- Install studs and nuts into the flange. The studs are not centered in the flange.
- Set stick-out dimension on the coupling side of the flange.
- Hand tighten nuts on generator side of flange.
- Verify stick-out measurement (**VERY IMPORTANT**)

TENSIONING (Bolt Installation)

- Check tensioner drawing for correct parts and part numbers.
- Apply a light coat of clean turbine oil or spray lubricant to the puller screw. **DO NOT USE "NEVER SEIZE" ON THE CONICAL THREADS.**
- Thread the puller screw into the stud.
- Install the spanner ring onto the nut.
- Insert an Allen wrench into the back side of the stud.
- Insert another Allen wrench into the puller screw. While holding the stud still, tighten the puller screw until hand tight and then loosen the puller screw 1/2 of a turn.
- Retighten the puller screw until slightly hand tight. **DO NOT BACK OFF PULLER SCREW.**
- Slide the foot over the puller stud and orientate the foot into position.
- Thread the tensioner onto puller screw until it stops. There should be a 1/16" to 3/16" gap between the foot and tensioner.
- Place the guard over the tensioner and position the guide pin into the hole in the backside of the stud.



215 Clinton Road
New Hartford, NY 13413
Tel: +1 315 768 4855
Fax: +1 315 768 4941
Email: info@riverhawk.com

CUSTOMER'S INFORMATION BOX
CONTENTS ARE INDEPENDENT OF RIVERHAWK DOCUMENT CONTROL

GE DRAWING NUMBER	REV
373A4078	

- Tighten the guard's knurled interlock fitting by hand until it presses firmly against tensioner (no gap).
- Push the center of the interlock fitting towards the tensioner while pulling back on the fitting's pull tabs until it locks onto the tensioner and release the pull tabs.
- Connect the hydraulic pump to the tensioner and tension to 50%. Consult manual for correct pressure.
- Use the pin wrench to turn the spanner ring to firmly tighten nut with 10 ft·lbs [13.5 N·m] of torque.
- Release pressure and allow the tensioner to fully retract.
- Disconnect the hose and release the interlock fitting by pushing the center of the interlock fitting towards the tensioner while pulling back on the fitting's pull tabs.
- Loosen the knurled interlock fitting and remove the guard.
- Unscrew the tensioner from the puller screw.
- Remove the foot, the puller screw, and the spanner ring.
- Move to the next stud in the pattern and repeat the previous steps. Tension all studs to 50% before proceeding to final pressure.
- Repeat above steps at final pressure.
- Measure final stud length and record on stretch datasheets. Calculate stretch and verify per section 9.3.
- Torque the nuts' set screws.

DETENSIONING (Stud Removal)

- If present, loosen the windage plugs' set screws and remove the windage plugs from the studs.
- Loosen nuts' set screws



215 Clinton Road
New Hartford, NY 13413
Tel: +1 315 768 4855
Fax: +1 315 768 4941
Email: info@riverhawk.com

CUSTOMER'S INFORMATION BOX
CONTENTS ARE INDEPENDENT OF RIVERHAWK DOCUMENT CONTROL

GE DRAWING NUMBER	REV
373A4078	

- Inspect and clean studs' conical threads. **Do not continue until ALL debris is removed from the threads!** See instruction manual IM-220. **Do not try to use the tensioner to remove a damaged stud!**
- Apply a light coat of clean turbine oil or spray lubricant to the puller screw. **DO NOT USE "NEVER SEIZE" ON THE CONICAL THREADS.**
- Thread the puller screw into the stud.
- Install the spanner ring onto the nut.
- Insert an Allen wrench into the back side of the stud.
- Insert another Allen wrench into the puller screw. While holding the stud still, tighten the puller screw until hand tight and then loosen the puller screw 1/2 of a turn.
- Retighten the puller screw until slightly hand tight. **DO NOT BACK OFF PULLER SCREW.**
- Slide the foot over the puller stud and orientate the foot into position.
- Thread the tensioner onto puller screw until it stops. There should be a 1/16" to 3/16" gap between the foot and tensioner.
- Place the guard over the tensioner and position the guide pin into the hole in the backside of the stud.
- Tighten the guard's knurled interlock fitting by hand until it presses firmly against tensioner (no gap).
- Push the center of the interlock fitting towards the tensioner while pulling back on the fitting's pull tabs until it locks onto the tensioner and release the pull tabs.
- Connect the hydraulic pump to the tensioner and tension to final pressure. Consult manual for correct pressure per section 11.2.
- Loosen nut with the spanner ring and pin wrench.
- Release pressure and allow the tensioner to fully retract.
- Disconnect the hose and release the interlock fitting by pushing the center of the interlock fitting towards the tensioner while pulling back on the fitting's pull tabs.

CUSTOMER'S INFORMATION BOX

CONTENTS ARE INDEPENDENT OF RIVERHAWK DOCUMENT CONTROL

GE DRAWING NUMBER	REV
373A4078	



215 Clinton Road
 New Hartford, NY 13413
 Tel: +1 315 768 4855
 Fax: +1 315 768 4941
 Email: info@riverhawk.com

- Loosen the knurled interlock fitting and remove the guard.
- Unscrew the tensioner from the puller screw.
- Remove the foot, puller screw, and spanner ring. It may be necessary to insert an Allen wrench into the backside of the stud to stop the stud from rotating.
- Move to the next stud in the pattern.

4.0 General Preparations

Read and understand all instructions before installing and tensioning studs.

Operators should be trained or have previous experience using Riverhawk tensioning equipment. Training will minimize the chance of improper use of the equipment.

The hydraulic tooling including the hydraulic hoses should be inspected prior to use. Inspection guidelines are listed in the following sub-sections.

This equipment produces very high hydraulic pressures and very high forces. Operators must exercise caution and wear the appropriate personal protective equipment when handling and operating the hydraulic tooling.

High-pressure oil from the hydraulic pump pressurizes the tensioner which generates a very large force that actually stretches the stud. As the stud is stretched the nut lifts off the flange. The nut is then turned by hand using the supplied spanner ring. Once the nut is tight against the flange, the pressure in the tensioner is released. The hardware is now clamping the flange together.

4.1 Machine Preparation

The flange to be tensioned must be fully closed prior to positioning of studs in the flanges. There must be provisions for turning the shafts. Also, it will be advantageous to remove as many obstructions as possible from the flange area, such as speed probes, shipping plates, conduit, and other protective materials that may interfere with the tensioner.



215 Clinton Road
New Hartford, NY 13413
Tel: +1 315 768 4855
Fax: +1 315 768 4941
Email: info@riverhawk.com

CUSTOMER'S INFORMATION BOX
CONTENTS ARE INDEPENDENT OF RIVERHAWK DOCUMENT CONTROL

GE DRAWING NUMBER	REV
373A4078	

4.2 Hardware – Balance

The studs are supplied in a component balanced set for the entire flange. A stud can be exchanged with another stud in its set without affected the overall balance of the equipment. Do not exchange a stud from one set with another stud from a different set for another turbine. When shipped from Riverhawk, the studs are not assigned to any specific hole in the bolted flange; this is optional and can be done at the installation site. The set size is determined by the relevant GE order drawing (see section 2.0).

The nuts are supplied in component balanced sets for the entire flange. A nut can be exchanged with another nut in its set without affected the overall balance of the equipment. Do not exchange a nut from one set with another nut from a different set for another turbine. When shipped from Riverhawk, the nuts are not assigned to any specific hole in the bolted flange; this is optional and can be done at the installation site. The set size is determined by the relevant GE order drawing (see section 2.0).

A weight balance certification is supplied with each order. Store this certification in an appropriate location as it will be needed for the acquisition of replacement equipment.

4.3 Tensioner – Care and Handling

When not in use, the tensioner shall be maintained in a clean environment and all caps and plugs for hydraulic openings and fittings must be in place.

Use ISO 32 grade oil.

When in use, the tensioner shall be protected from sand and grit.

See section 12 for long term storage requirements.

4.4 Hand Tools

Several hand wrenches and micrometers may be required to perform installation and measurement of the studs:

5/8" Wrench	1' to 2' (30cm-60cm) Breaker Bar
3/4" Wrench	3' to 4' (90cm-120cm) Breaker Bar
A set of Allen Wrenches	5" to 6" (125mm-150mm) Micrometer or Caliper
1/2" Square Drive – 1/2" Hex-Bit Socket	8" to 9" (200mm-225mm) Micrometer or Caliper



215 Clinton Road
 New Hartford, NY 13413
 Tel: +1 315 768 4855
 Fax: +1 315 768 4941
 Email: info@riverhawk.com

CUSTOMER'S INFORMATION BOX
 CONTENTS ARE INDEPENDENT OF RIVERHAWK DOCUMENT CONTROL

GE DRAWING NUMBER	REV
373A4078	

4.5 Special Tools

Hydraulic Tensioner Kit: HT-6745 Hydraulic Tensioner, 1-1/8"
(reference GE VENDOC 101B0646)

HT-6754 Hydraulic Tensioner, 2"
(see manual IM-406, GE VENDOC 373A4099)
(reference GE VENDOC 101B0647)

Hydraulic Pump Kit: AP-0532 Air-Operated Hydraulic Pump
(reference GE VENDOC 359B2502)

Stud Cleaning Kit: GT-4354 Stud Cleaning Kit
(recommended)
(reference GE VENDOC 373A4027)

CAUTION

Riverhawk recommends that the tensioners be returned to Riverhawk for periodic inspections. Replacement of obsolete tensioners is recommended. Functional upgrades are also recommended. The Riverhawk Service Returns Coordinator should be notified 3-6 months prior to a planned outage to schedule an inspection service.

5.0 Hardware Set Preparations

5.1 Nut Preparation



Picture 5A - Riverhawk Locknut



215 Clinton Road
New Hartford, NY 13413
Tel: +1 315 768 4855
Fax: +1 315 768 4941
Email: info@riverhawk.com

CUSTOMER'S INFORMATION BOX
CONTENTS ARE INDEPENDENT OF RIVERHAWK DOCUMENT CONTROL

GE DRAWING NUMBER	REV
373A4078	

If there is any visible damage on a nut, do not use the nut and contact the Riverhawk Company for a replacement nut. Please be prepared to supply the turbine number, weight certification, and digital photographs for evaluation.

5.1.1 Nut Cleaning - New Installations

For new installations, the nuts should come sealed from the factory and will need no cleaning.

5.1.2 Nut Cleaning - Old Installations

Previously installed nuts require cleaning as follows: Wire brush using a petroleum-based solvent to remove any foreign material on the external surfaces and threads.

5.2 Stud Preparation

Check the stud for any visible damage. If there is any visible damage, do not use the stud and contact the Riverhawk Company for a replacement stud. Please be prepared to supply the turbine number, weight certification, and digital photographs for evaluation.

CAUTION

It is especially important to check the condition of the conical thread used to tension the stud. Thread damage from previous abuse can lead to failure of the stud or tensioning equipment.

The conical threads of each stud must be clean of grit and dirt before installation or removal. This ensures the proper seating of the puller screw.

5.2.1 Stud Cleaning - New Installations

For new installations, the studs should come sealed from the factory and will need no cleaning.

5.2.2 Stud Cleaning - Old Installations

Previously installed studs may require cleaning. Clean conical threads should have a bright and shiny appearance.

If cleaning is required, follow these steps:

1. Blow out the threads with compressed air to remove loose debris and dry conical threads. Do not apply a solvent or other cleaning solution to the threads as this may chemically attack the stud.



215 Clinton Road
New Hartford, NY 13413
Tel: +1 315 768 4855
Fax: +1 315 768 4941
Email: info@riverhawk.com

CUSTOMER'S INFORMATION BOX
CONTENTS ARE INDEPENDENT OF RIVERHAWK DOCUMENT CONTROL

GE DRAWING NUMBER	REV
373A4078	

2. Use Stud Cleaning Kit, GT-4354 or a similar 1/2" diameter Brass power brush.



Picture 5B - Brass Power Brush

3. Insert the brush into an electric drill and set drill to run in a counterclockwise direction at high speed.
4. Work the drill in a circular motion while moving the brush in and out to clean all of the threads. Try not to hold the brush in one place too long, so as not to remove the stud's protective coating.
5. Blow out the threads with compressed air to remove loosened debris.
6. Visually inspect threads for cleanliness. Threads should be bright and shiny.
7. Repeat if any dirt can be seen in the threads.
8. Inspect threads for any damage that may have been caused by previous installation.
9. Do **not** apply "Never Seize" to the stud's threads.
10. Finish the cleaning process by rinsing in a volatile solvent such as acetone and allow the stud to dry.

5.3 Stud Length Measurement

Measure and record the initial lengths of the studs. The following suggestions will improve your results.

- **Plan to start and finish any flange in the same day.**
- **Studs and flange must be at the same temperature.**
- **Number each stud with a marker for later stretch measurement tracking.**
- **Mark the location of measurement on stud end with a permanent marker.**
- **Measure each stud to nearest 0.001 inch (.01 mm).**
- **Record each measurement on the supplied record sheets at the end of this manual.**
- **Do not allow the measuring instruments to sit in the sun.**
- **The same person should make all measurements.**



215 Clinton Road
New Hartford, NY 13413
Tel: +1 315 768 4855
Fax: +1 315 768 4941
Email: info@riverhawk.com

CUSTOMER'S INFORMATION BOX
CONTENTS ARE INDEPENDENT OF RIVERHAWK DOCUMENT CONTROL

GE DRAWING NUMBER	REV
373A4078	

6.0 Stud and Nut Assembly

Refer to the hardware assembly drawing (HF-xxxx) listed in Section 2.0 of the manual.

1. Assemble the cylindrical nut to the internal, conical thread end of the stud.
2. Slide the stud and cylindrical nut assembly into the flange as shown in Figures 6A and 6B.

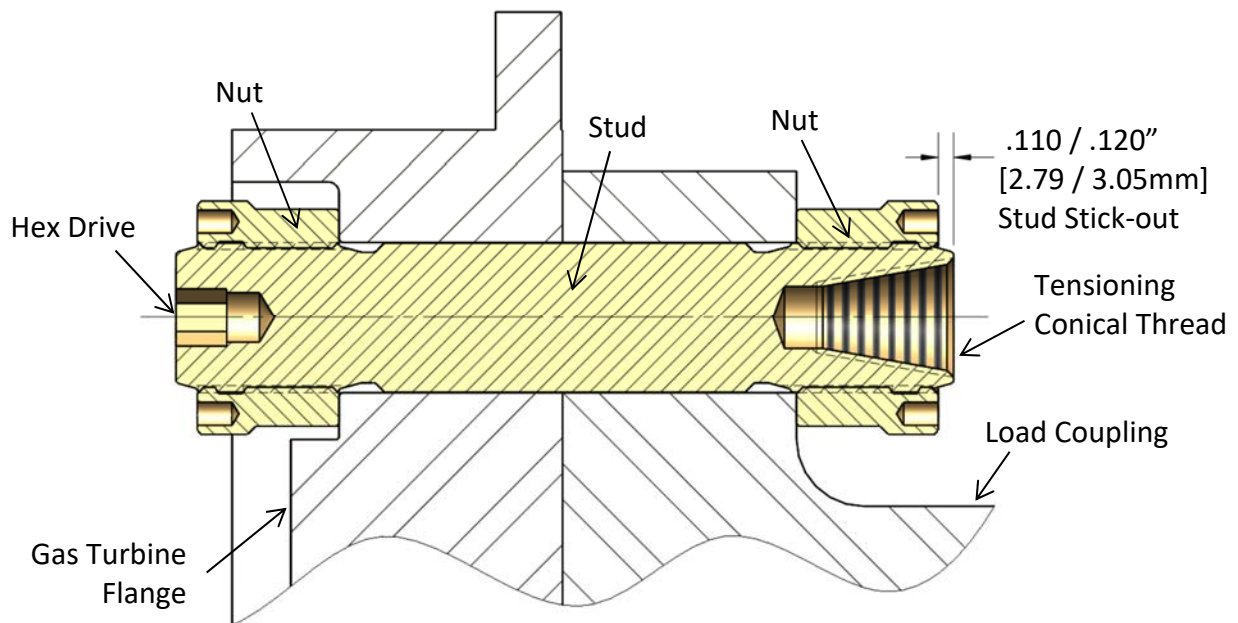

Figure 6A – Cross-section View of Gas Turbine to Load Coupling Bolted Flange Connection

Note: Coupling flange appearance may vary depending on its manufacturer



215 Clinton Road
 New Hartford, NY 13413
 Tel: +1 315 768 4855
 Fax: +1 315 768 4941
 Email: info@riverhawk.com

CUSTOMER'S INFORMATION BOX
 CONTENTS ARE INDEPENDENT OF RIVERHAWK DOCUMENT CONTROL

GE DRAWING NUMBER	REV
373A4078	

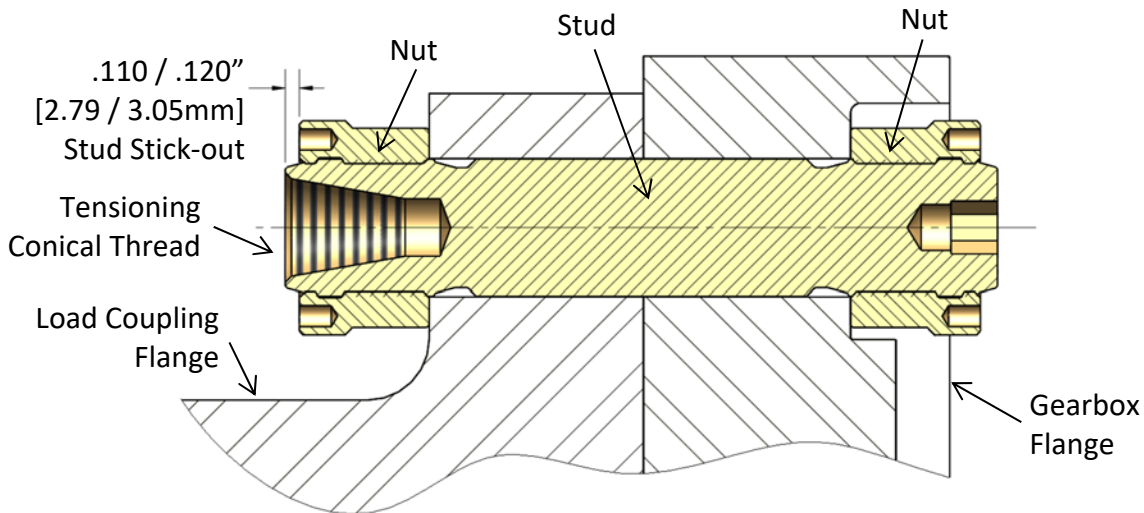

Figure 6B – Cross-section View of Load Coupling to Gearbox Bolted Flange Connection

Note: Coupling flange appearance may vary depending on its manufacturer

3. Install the other nut on the backside.
4. Adjust the nut/stud assembly so that the stud sticks out (protrudes) from the face of the nut the amount shown. Best practice is to verify the stud stick-out dimension with the hardware set drawing for your application (see section 2). If you don't have a hardware set drawing, it can be found in the GE Vendocs system or contact Riverhawk Company

SETTING THE STUD STICK-OUT IS CRITICAL FOR PROPER TENSIONER OPERATION. A metal stick-out gage may be provided with the tensioner to assist the operator in setting the protrusion dimension.



Picture 6C – Use of Stick-Out Gage on the 6FA Load Coupling stud



Picture 6D – Use of Stick-Out Gage on the 6F.03 Load Coupling stud



215 Clinton Road
 New Hartford, NY 13413
 Tel: +1 315 768 4855
 Fax: +1 315 768 4941
 Email: info@riverhawk.com

CUSTOMER'S INFORMATION BOX
 CONTENTS ARE INDEPENDENT OF RIVERHAWK DOCUMENT CONTROL

GE DRAWING NUMBER	REV
373A4078	



Picture 6E – Use of Drop Gage to measure stick-out

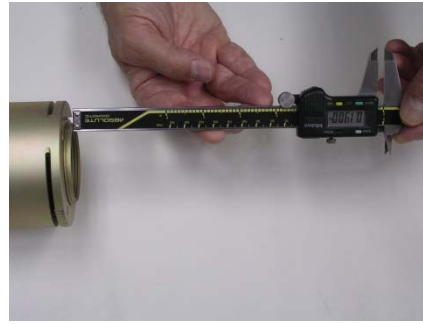

Picture 6F – Use of Calipers to measure stick-out

5. Hand tighten the assembly to a snug fit.
6. Recheck the stud stick-out length. If the stick-out length does not match the hardware drawing, adjust the nuts as necessary.

7.0 Hydraulic Tensioner Equipment Assembly

7.1 Hydraulic Equipment Inspection

7.1.1 Hydraulic Tensioner Inspection

CAUTION

Riverhawk recommends that the tensioner be returned to Riverhawk for periodic inspections. Replacement of obsolete tensioners is recommended. Functional upgrades are also recommended. Riverhawk should be notified 3-6 months prior to a planned outage to schedule an inspection service.

Do **not** bleed the air from the hydraulic lines and tensioner at this time. See section 8 for bleeding instructions on when to bleed the air from the hydraulic lines.

WARNING

To avoid failure, ensure safety, and proper operation, the tensioner assembly must be installed on a stud in the flange before bleeding and pressurizing the tensioner. Do not use the tensioner at any pressure unless the tool is installed on a stud in a flange.

Clean puller screw and check for any debris and dents.



215 Clinton Road
New Hartford, NY 13413
Tel: +1 315 768 4855
Fax: +1 315 768 4941
Email: info@riverhawk.com

CUSTOMER'S INFORMATION BOX
CONTENTS ARE INDEPENDENT OF RIVERHAWK DOCUMENT CONTROL

GE DRAWING NUMBER	REV
373A4078	

IM-364 Revision G
Page 19 of 40

Inspect the tensioner guard for any signs of damage including cracked welds. Any guards modified in the field should be replaced. Bent guards should be replaced. Also, be sure the rubber pad is in place on the guard, if missing, replace.

Inspect the outside of the tensioner for discoloration patterns that may indicate submersion and internal damage.

Perform an inventory of the loose equipment supplied with the tensioner. An inventory list is provided on the tensioner's technical drawing (Riverhawk HT-xxxx listed in section 2.0 and 4.5). Replacement parts are available from Riverhawk.

7.1.1.1 Hydraulic Tensioner's Burst Disc Replacement

The hydraulic tensioner's burst disc is a key element in the overall safe use of the hydraulic tensioner. The burst disc's location is shown on the tensioner's technical drawing (Riverhawk HT-xxxx listed in section 2.0 and 4.5).

Each tensioner is shipped from our factory with one burst disc already installed in the tensioner and with another spare disc for field replacement. Extra burst discs are available from Riverhawk for replacement purposes.

To replace a damaged burst disc:

1. Remove the hydraulic port's dispersion nut, compression ring, and damaged burst disc.
2. Discard the damaged burst disc.
3. Clean the dispersion nut, compression ring, new burst disc, and the hydraulic port with a solvent to ensure a dirt-free installation.
4. Reassemble new burst disc, compression ring, and dispersion nut into the same hydraulic port.

Warning

A damaged burst disc must be replaced with a burst disc of the same design and pressure rating. Do not substitute a damaged burst disc with a different disc type, a different pressure rating, or a foreign object.

7.1.2 Hydraulic Pump Kit Inspection

Refer to the Hydraulic Pump Kit Instruction Manual, IM-293 (GE VENDOC 373A4058). The latest revision may be obtained by contacting Riverhawk Company or thru www.riverhawk.com.



215 Clinton Road
New Hartford, NY 13413
Tel: +1 315 768 4855
Fax: +1 315 768 4941
Email: info@riverhawk.com

CUSTOMER'S INFORMATION BOX
CONTENTS ARE INDEPENDENT OF RIVERHAWK DOCUMENT CONTROL

GE DRAWING NUMBER	REV
373A4078	

7.1.3 Hydraulic Hose Inspection

Check the hydraulic hose for any damage including bent hose ends and split outer lining. If any damaged is found, replace the hose immediately by contacting the Riverhawk Company.

7.2 Hydraulic Fittings

Information on the correct assembly of the hydraulic pump's and hydraulic hose's hydraulic fittings can be found in Appendix B1.

8.0 Assembly of Tensioner on a Stud

8.1 Handling of the Tensioner

The tensioner used in this application is designed to require no special lifting instructions. Do not drop any part of the tensioner on the operator or other nearby personnel.

8.2 Kit Assembly

Connect the hydraulic hose from the hydraulic pump to the tensioner. **Do not pressurize** the tensioner at this time or you may cause damage to the tensioner.

Refer to the hardware assembly drawing (HF-xxxx) listed in Section 2.0 of this manual and the tensioner assembly drawing (HT-xxxx) listed in Section 4.5 of this manual to determine how the tensioner must be assembled on the load coupling for its correct operation.



215 Clinton Road
New Hartford, NY 13413
Tel: +1 315 768 4855
Fax: +1 315 768 4941
Email: info@riverhawk.com

CUSTOMER'S INFORMATION BOX
CONTENTS ARE INDEPENDENT OF RIVERHAWK DOCUMENT CONTROL

GE DRAWING NUMBER	REV
373A4078	

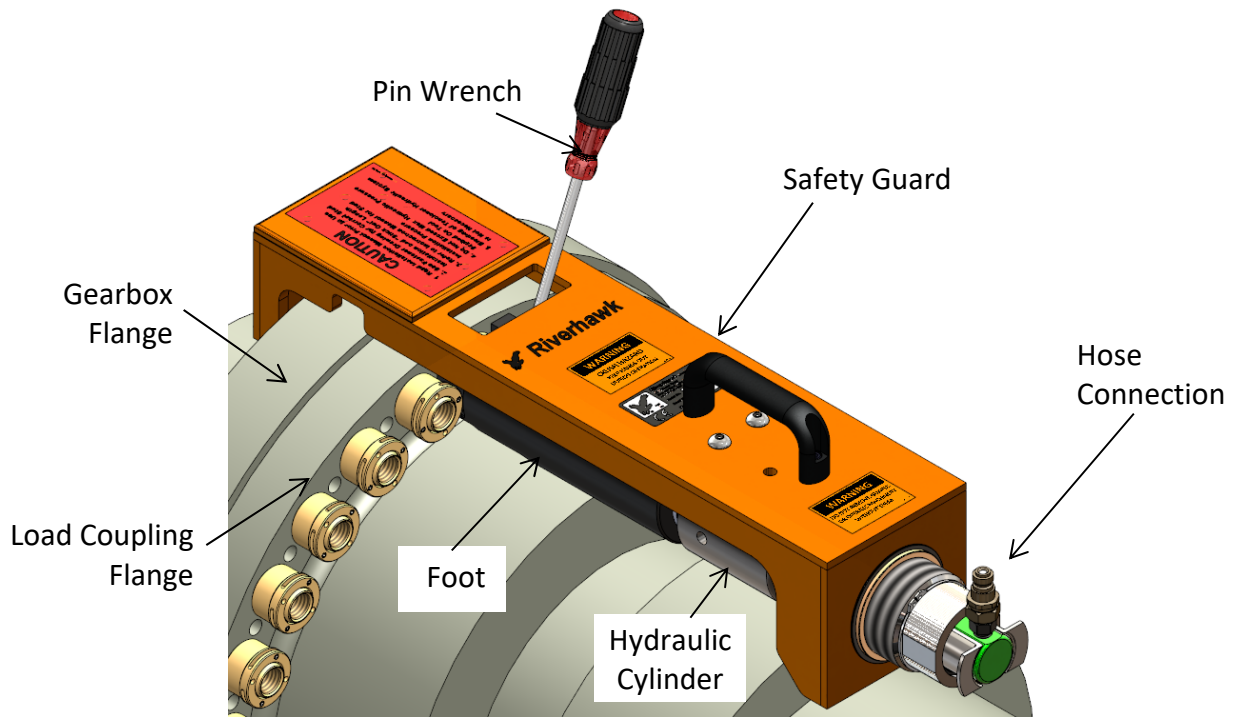

Picture 8A – Features of the Hydraulic Tensioner HT-6745

Note: Coupling flange appearance may vary depending on its manufacturer

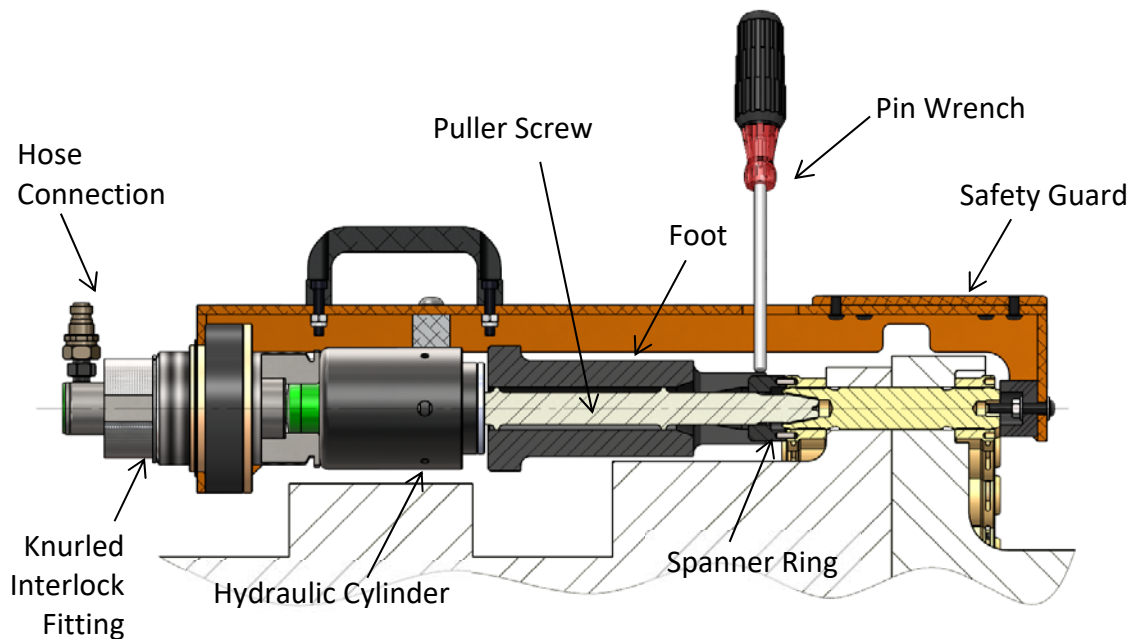

Picture 8B – Cutaway view of Hydraulic Tensioner HT-6745

Note: Coupling flange appearance may vary depending on its manufacturer



215 Clinton Road
 New Hartford, NY 13413
 Tel: +1 315 768 4855
 Fax: +1 315 768 4941
 Email: info@riverhawk.com

CUSTOMER'S INFORMATION BOX
 CONTENTS ARE INDEPENDENT OF RIVERHAWK DOCUMENT CONTROL

GE DRAWING NUMBER	REV
373A4078	

Note: Before threading the puller screw into the stud, carefully check the cleanliness of both the stud's and the puller screw's conical threads. Apply a light coat of clean turbine oil or a spray lubricant to the puller screw. Do not use "Never Seize" on the conical threads. This procedure will ease assembly and assure positive mating of the threads before tightening.

Assembly sequence is as follows:

1. Open the hydraulic return valve on the pump to allow hydraulic fluid to be pushed back from the puller tool into the pump reservoir. (This is automatic on the air-operated hydraulic pump)
2. Insert the puller screw into the tapered thread of the stud and hand tighten. **Be sure not to cross-thread the puller screw.**
3. Place the spanner ring on the nut.
4. Using an Allen wrench, tighten the puller screw and then back off the puller screw 1/2 a turn.
5. Retighten the puller screw by hand until it is fully inserted. **DO NOT BACK OFF THE PULLER SCREW.**
6. Place the foot over the puller screw and orientate it into position.
7. Thread the tensioner onto the puller screw until it stops. Please note that the internal stop inside the tensioner will cause a gap in between the foot and tensioner. The gap should be 1/16" [1.6mm] to 3/16" [4.8mm]. **DO NOT ATTEMPT TO TIGHTEN THE TENSIONER AGAINST THE FOOT.**
8. Place the guard over the tensioner and position the guide pin into the hole in the backside of the stud.
9. Tighten the knurled interlock fitting by hand until it firmly presses against the tensioner. There should be no gap between the tensioner the interlock fitting.
10. Activate the custom connector from the rear of guard by pushing on the center with your thumb and pulling the tabs with your fore finger and middle finger. Push the assembly forward until it locks into the tensioner. Release fingers from the tabs and then remove thumb, ensure connection is firmly engaged or else the tensioner will not be connected to the pump.



215 Clinton Road
New Hartford, NY 13413
Tel: +1 315 768 4855
Fax: +1 315 768 4941
Email: info@riverhawk.com

CUSTOMER'S INFORMATION BOX
CONTENTS ARE INDEPENDENT OF RIVERHAWK DOCUMENT CONTROL

GE DRAWING NUMBER	REV
373A4078	

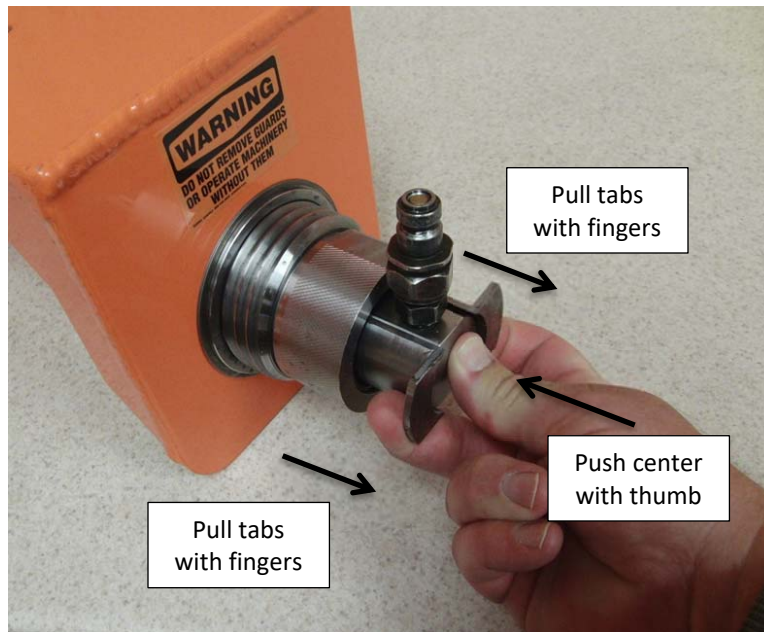

Picture 8E - Activation of the safety interlock

11. Connect the hydraulic pump to the tensioner. The tensioner should now be completely assembled and ready for use.

8.3 Bleeding Hydraulic System

WARNING

To avoid failure, ensure safety, and proper operation, the tensioner assembly must be installed on a stud in the flange before bleeding and pressurizing the tensioner. Do not use the tensioner at any pressure unless the tool is installed on a stud in a flange.

Bleeding of the hydraulic system is not necessary with this tensioner design.

9.0 Stud Tensioning

The studs will be tensioned in two steps, at 50% pressure and at final pressure. Follow the tensioning sequence for each flange joint as defined on the record sheets found at the end of this manual.

9.1 Tensioning at 50% pressure

After the tensioner is properly installed apply hydraulic pressure to the tool. Bring the pressure to the 50% level in accordance with the following table.

CUSTOMER'S INFORMATION BOX
CONTENTS ARE INDEPENDENT OF RIVERHAWK DOCUMENT CONTROL

GE DRAWING NUMBER	REV
373A4078	



215 Clinton Road
New Hartford, NY 13413
Tel: +1 315 768 4855
Fax: +1 315 768 4941
Email: info@riverhawk.com

WARNING

The safety cage must be in place at all times. Keep hands out of designated areas at all times when the tensioner is pressurized otherwise personal injury can occur.

CAUTION

Before threading the puller screw into the stud, carefully check the cleanliness of both the stud's and the puller screw's conical threads. Apply a light coat of clean turbine oil or a spray lubricant to the puller screw. This procedure will ease assembly and assure positive mating of the threads before tightening. Do not use "Never Seize" on the conical threads.

CAUTION

Do not exceed the maximum pressure marked on the tensioner. Excessive pressure can damage the stud and puller screw.

CAUTION

Do not tighten the nut while the tool is coming up to pressure; wait until pressure is achieved before attempting to tighten the nut with the spanner ring. If the tool is not properly installed, the tool could jump off the stud while coming up to pressure.

<u>Flange Position</u>	<u>Stud Size</u>	<u>50% Pressure</u>	<u>50% Stretch</u>
Gas Turbine to Load Coupling	1-1/8" [29 mm]	9000 psi [620 bar]	Do not measure Do not use
Load Coupling to Load Gear	1-1/8" [29 mm]	9000 psi [620 bar]	Do not measure Do not use

Firmly tighten the cylindrical nuts with approximately 10 ft·lbs [13.5 N·m] of torque using the pin wrench and spanner ring. Continue to turn the nut until it contacts the flange.

9.2 Removing the Tensioner from an Installed Stud

The tensioner removal is accomplished by the follows steps:

1. Release the hydraulic pressure by either releasing the hand switch on the AP-0532 Pump Kit or by opening the valve on the MP-0130 Manual Pump Kit and leave the valve open.
2. Unscrew the knurled interlock fitting at the end of the guard and remove the guard from the tensioner.
3. Unscrew the tensioner from puller screw.



215 Clinton Road
New Hartford, NY 13413
Tel: +1 315 768 4855
Fax: +1 315 768 4941
Email: info@riverhawk.com

CUSTOMER'S INFORMATION BOX
CONTENTS ARE INDEPENDENT OF RIVERHAWK DOCUMENT CONTROL

GE DRAWING NUMBER	REV
373A4078	

4. Remove foot from around the puller screw.
5. Remove the spanner ring from the nut.
6. Unscrew the puller screw using an Allen wrench. Tapping the Allen wrench with a hammer or the use of a breaker bar may be necessary to loosen the puller screw. Do not use an impact wrench as this can damage the puller screw.
7. Move the tool to the next bolt hole following the tensioning pattern from the stretched record sheets at the end of this manual.

9.3 Tensioning at Final Pressure

Repeat the pulling and tightening procedure stated above at full pressure. After all of the studs have been tensioned, measure the final stud length. The final pressure and required stretch values are listed in the following table.

WARNING

The safety cage must be in place at all times. Keep hands out of designated areas at all times when the tensioner is pressurized otherwise personal injury can occur.

CAUTION

Before threading the puller screw into the stud, carefully check the cleanliness of both the stud's and the puller screw's conical threads. Apply a light coat of clean turbine oil or a spray lubricant to the puller screw. This procedure will ease assembly and assure positive mating of the threads before tightening. Do not use "Never Seize" on the conical threads.

CAUTION

Do not exceed the maximum pressure marked on the tensioner. Excessive pressure can damage the stud and puller screw.

CAUTION

Do not tighten the nut while the tool is coming up to pressure; wait until pressure is achieved before attempting to tighten the nut with the spanner ring. If the tool is not properly installed, the tool could jump off the stud while coming up to pressure.

<u>Flange Position</u>	<u>Stud Size</u>	<u>Final Pressure</u>	<u>Final Stretch</u>
Gas Turbine to Load Coupling	1-1/8" [29 mm]	18000 psi [1240 bar]	0.010" - 0.012" [0.25 mm - 0.31 mm]
Load Coupling to Load Gear	1-1/8" [29 mm]	18000 psi [1240 bar]	0.010" - 0.012" [0.25 mm - 0.31 mm]

CUSTOMER'S INFORMATION BOX

CONTENTS ARE INDEPENDENT OF RIVERHAWK DOCUMENT CONTROL

GE DRAWING NUMBER	REV
373A4078	



215 Clinton Road
 New Hartford, NY 13413
 Tel: +1 315 768 4855
 Fax: +1 315 768 4941
 Email: info@riverhawk.com

Firmly tighten the cylindrical nuts with approximately 10 ft·lbs [13.5 N·m] of torque using the pin wrench and spanner ring. Continue to turn the nut until it contacts the flange.

Failure to achieve the correct final stretch values will result in an incorrectly tensioned stud.

Incorrect stretch values can be corrected by uninstalling some or all of the selected studs. Re-measure the initial length of the studs and repeat the installation instructions studs. Excessive stretch variations can also be corrected by the same method.

Have final stretch values approved by the supervisor responsible for the installation.

10.0 Thread Locking the Nut

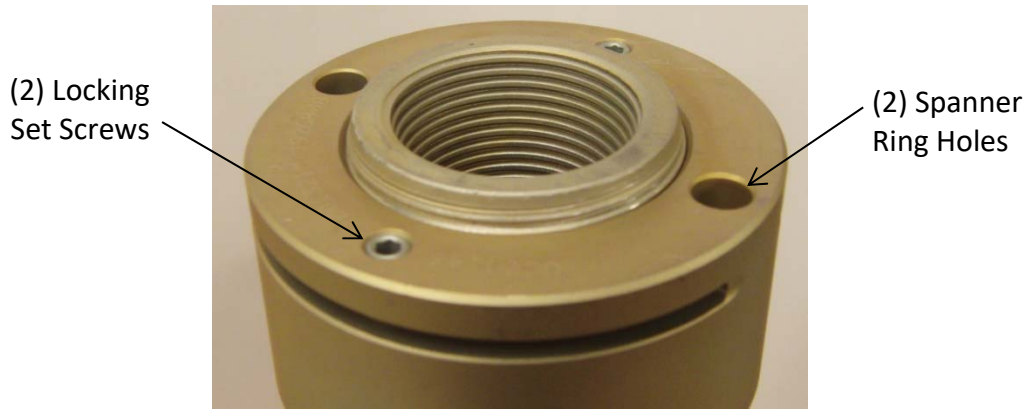

Picture 10A - Riverhawk Locknut

Mechanical lock nuts have two set screws located in the top face. Before threading the nut onto the stud, check to be certain the set screws are free to turn. Once the nut is seated torque the set screws to the values specified in the following table. When seated and torqued to the values specified, the load created by the set screw displaces the thread of the nut in the area of the web thereby creating the desired locking action.

<u>Flange Position</u>	<u>Stud Size</u>	<u>Set Screw Size</u>	<u>Torque</u>
Gas Turbine to Load Coupling	1-1/8" [29 mm]	#10-32UN	30 in·lbs - 36 in·lbs [3.4 N·m – 4.1 N·m]
Load Coupling to Load Gear	1-1/8" [29 mm]	#10-32UN	30 in·lbs - 36 in·lbs [3.4 N·m – 1.1 N·m]

CUSTOMER'S INFORMATION BOX
CONTENTS ARE INDEPENDENT OF RIVERHAWK DOCUMENT CONTROL

GE DRAWING NUMBER	REV
373A4078	



215 Clinton Road
New Hartford, NY 13413
Tel: +1 315 768 4855
Fax: +1 315 768 4941
Email: info@riverhawk.com

11.0 Stud and Nut Removal

11.1 Handling of the Tensioner

The tensioner used in this application is designed for no special lifting instructions. Do not drop any part of the tensioner on the operator or other nearby personnel.

11.2 Stud and Nut Removal

WARNING

The safety cage must be in place at all times. Keep hands out of designated areas at all times when the tensioner is pressurized otherwise personal injury can occur.

CAUTION

Before threading the puller screw into the stud, carefully check the cleanliness of both the stud's and the puller screw's conical threads. Apply a light coat of clean turbine oil or a spray lubricant to the puller screw. This procedure will ease assembly and assure positive mating of the threads before tightening. Do not use "Never Seize" on the conical threads.

CAUTION

Do not exceed the maximum pressure marked on the tensioner. Excessive pressure can damage the stud and puller screw.

CAUTION

Do not tighten the nut while the tool is coming up to pressure; wait until pressure is achieved before attempting to tighten the nut with the spanner ring. If the tool is not properly installed, the tool could jump off the stud while coming up to pressure.

Refer to the hardware assembly drawing (HF-xxxx) listed in Section 2.0 of this manual and the tensioner assembly drawing (HT-xxxx) listed in Section 4.5 of this manual to determine how the tensioner must be assembled on the load coupling for its correct operation.

Section 8.0 contains diagrams of the tensioner equipment.

Note: Before threading the puller screw into the stud, carefully check the cleanliness of both the stud's and the puller screw's conical threads. Apply a light coat of clean turbine oil or a spray lubricant to the puller screw. Do not use "Never Seize" on the conical threads. This procedure will ease assembly and assure positive mating of the threads before tightening.

Disassembly sequence is as follows:



215 Clinton Road
New Hartford, NY 13413
Tel: +1 315 768 4855
Fax: +1 315 768 4941
Email: info@riverhawk.com

CUSTOMER'S INFORMATION BOX
CONTENTS ARE INDEPENDENT OF RIVERHAWK DOCUMENT CONTROL

GE DRAWING NUMBER	REV
373A4078	

1. If present, remove the windage plugs from the studs by loosening the plug's set screws with an Allen wrench and then unscrew the plug from the stud. It may be necessary to use either a flat-bladed screwdriver or another Allen wrench to stop the windage plug from rotating. Do not misplace the set screws.
2. Using a wire brush (GT-4354) and shop air, clean the internal tapered thread of the stud to remove any debris/deposits which may have accumulated during service as described in section 5.2.2. Do not continue until ALL debris is removed from the threads.

WARNING

Do not use a hydraulic tensioner to remove a stud with damaged conical threads.

3. With an Allen wrench, loosen the nut's two locking set screws but do not remove them from the nut.



Picture 11A - Loosening of a nut's set screws

4. Connect the hydraulic hose from the hydraulic pump to the tensioner. **Do not pressurize** the tensioner at this time or you may cause damage to the tensioner.
5. Open the hydraulic return valve on the pump to allow hydraulic fluid to be pushed back from the puller tool into the pump reservoir. (This is automatic on the air-operated hydraulic pump)
6. Insert the puller screw into the tapered thread of the stud and hand tighten. **Be sure not to cross-thread the puller screw.**
7. Place the spanner ring on the nut.
8. Using an Allen wrench, tighten the puller screw and then back off the puller screw 1/2 a turn.



215 Clinton Road
New Hartford, NY 13413
Tel: +1 315 768 4855
Fax: +1 315 768 4941
Email: info@riverhawk.com

CUSTOMER'S INFORMATION BOX
CONTENTS ARE INDEPENDENT OF RIVERHAWK DOCUMENT CONTROL

GE DRAWING NUMBER	REV
373A4078	

9. Retighten the puller screw by hand until it is fully inserted. **DO NOT BACK OFF THE PULLER SCREW.**
10. Place the foot over the puller screw and orientate it into position.
11. Thread the tensioner onto the puller screw until it stops. Please note that the internal stop inside the tensioner will cause a gap in between the foot and tensioner. The gap should be 1/16" [1.6mm] to 3/16" [4.8mm]. **DO NOT ATTEMPT TO TIGHTEN THE TENSIONER AGAINST THE FOOT.**
12. Place the guard over the tensioner and position the guide pin into the hole in the backside of the stud.
13. Tighten the knurled interlock fitting by hand until it firmly presses against the tensioner. There should be no gap between the tensioner the interlock fitting.
14. Activate the custom connector from the rear of guard by pushing on the center with your thumb and pulling the tabs with your fore finger and middle finger. Push the assembly forward until it locks into the tensioner. Release fingers from the tabs and then remove thumb, ensure connection is firmly engaged or else the tensioner will not be connected to the pump.

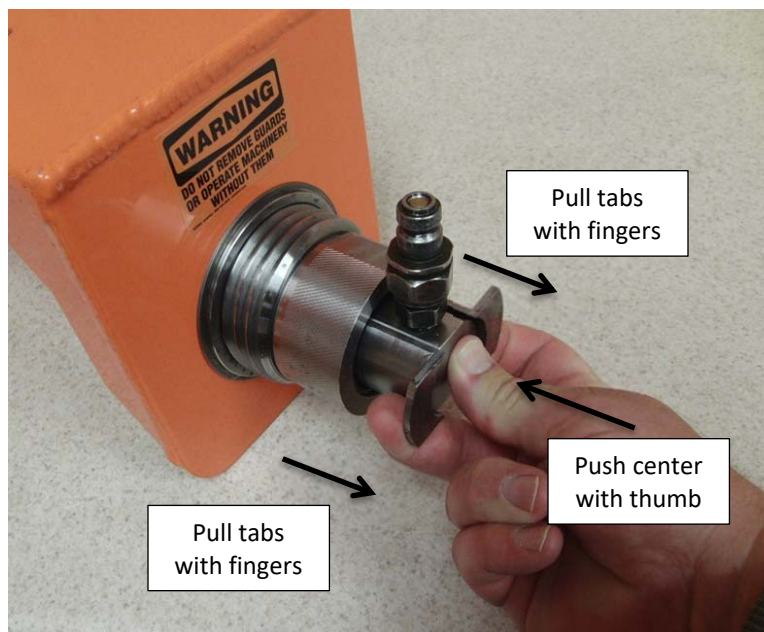

Picture 11B - Activation of the safety interlock

15. Connect the hydraulic pump to the tensioner and apply the appropriate hydraulic pressure per this table.



215 Clinton Road
 New Hartford, NY 13413
 Tel: +1 315 768 4855
 Fax: +1 315 768 4941
 Email: info@riverhawk.com

CUSTOMER'S INFORMATION BOX
 CONTENTS ARE INDEPENDENT OF RIVERHAWK DOCUMENT CONTROL

GE DRAWING NUMBER	REV
373A4078	

<u>Flange Position</u>	<u>Stud Size</u>	<u>Final (100%) Pressure</u>
Gas Turbine to Load Coupling	1-1/8" [29 mm]	18000 psi [1240 bar]
Load Coupling to Load Gear	1-1/8" [29 mm]	18000 psi [1240 bar]

16. Turn the spanner ring with the pin wrench. Loosen and turn the nut approximately 3/4 of a turn.

17. Release the hydraulic pressure.

11.3.1 Removing the Tensioner from a Stud

The tensioner removal is accomplished by the follows steps:

1. Release the hydraulic pressure by either releasing the hand switch on the AP-0532 Pump Kit or by opening the valve on the MP-0130 Manual Pump Kit and leave the valve open.
2. Unscrew the knurled interlock fitting at the end of the guard and remove the guard from the tensioner.
3. Unscrew the tensioner from puller screw.
4. Remove foot from around the puller screw.
5. Remove the spanner ring from the nut.
6. Unscrew the puller screw using an Allen wrench. Tapping the Allen wrench with a hammer or the use of a 1'-2' breaker bar may be necessary to loosen the puller screw. Do not use an impact wrench as this can damage the puller screw.
7. Move the tool to the next bolt hole following the tensioning pattern from the stretched record sheets at the end of this manual.

12.0 Storage Instructions

Follow these directions to properly store your hydraulic tensioner and hydraulic pump kit for long term storage and shipment.

If any damage is observed, contact the Riverhawk Company to schedule a maintenance inspection.



215 Clinton Road
New Hartford, NY 13413
Tel: +1 315 768 4855
Fax: +1 315 768 4941
Email: info@riverhawk.com

CUSTOMER'S INFORMATION BOX
CONTENTS ARE INDEPENDENT OF RIVERHAWK DOCUMENT CONTROL

GE DRAWING NUMBER	REV
373A4078	

12.1 Hydraulic Pump Kit Storage

Refer to the Hydraulic Pump Kit Instruction Manual, IM-293 (GE VENDOC 373A4058). The latest revision may be obtained by contacting Riverhawk Company or thru www.riverhawk.com.

12.2 Hydraulic Tensioner Storage

Check the tensioner for any damage:

1. Clean puller screw and check for any debris and dents.
2. Knurled interlock fitting should be clean and free to rotate.
3. Inspect the tensioner guard for any signs of damage. Bent guards must be replaced.

If any damage is observed, contact the Riverhawk Company to schedule a maintenance inspection.

Place the protective plastic cap on the guard's knurled interlock fitting.

Coat the hydraulic tensioner with a light coat of oil and place the tensioner into the original shipping container.

12.3 Store shipping container

Secure the hydraulic pump and hydraulic tensioner into the original shipping containers using the supplied wood braces.

Seal the original shipping container and store under shelter and protected from moisture, sand, and grit.

13.0 Frequently Asked Questions

This section contains some frequently asked questions and problems. If the steps listed here do not solve your problem, contact the Riverhawk Company thru our website, email, or phone call.

Q: Can I rent a hydraulic tensioner kit?

A: Yes, Riverhawk has rental tensioner kits available for most of our hydraulic tensioners.



215 Clinton Road
New Hartford, NY 13413
Tel: +1 315 768 4855
Fax: +1 315 768 4941
Email: info@riverhawk.com

CUSTOMER'S INFORMATION BOX
CONTENTS ARE INDEPENDENT OF RIVERHAWK DOCUMENT CONTROL

GE DRAWING NUMBER	REV
373A4078	

Q: A tensioner has pulled itself out of the stud's conical threads. Can I continue using a tensioner on this stud?

A: No. Both the tensioner and the stud may have been damaged and must be removed from the work area. If the stud is tensioned, a Nut Buster repair kit, from Riverhawk, must be used to remove the damaged stud by drilling out the nut. Leaving a damaged stud in place will lead to a safety hazard on future outages.

Riverhawk can supply a replacement stud and nut based on the initial weight certification supplied with the hardware set (see section 4.2). The damaged tensioner should also be returned to Riverhawk for inspection and repair.

If a stud must be left in place, paint the damaged stud with a generous amount of indelible, bright-colored paint. Notify the appropriate GE Safety and Service personnel. Note the location of the damaged stud in the services notes for the machine.

Q: The hydraulic tensioner has been taken up to its final pressure. The final stretch length is short of the final stretch target. What is the next step?

A: Do not increase the hydraulic pressure. Check if the hydraulic pump is set to the right pressure. Install the tensioner and re-pressurize the tensioner to the final pressure then recheck the stretch measurement. If the stretch value is still short, remove the stud from the hole and re-measure the stud's initial length then try to install the stud again.

Q: The hydraulic tensioner has been taken up to its final pressure. The final stretch length is larger than the final stretch target. What is the next step?

A: Remove the stud from the bolt hole. Check if the hydraulic pump is set to the right pressure. Re-measure the stud's initial length then try to install the stud again.



215 Clinton Road
New Hartford, NY 13413
Tel: +1 315 768 4855
Fax: +1 315 768 4941
Email: info@riverhawk.com

CUSTOMER'S INFORMATION BOX
CONTENTS ARE INDEPENDENT OF RIVERHAWK DOCUMENT CONTROL

GE DRAWING NUMBER	REV
373A4078	

- Q:** The tensioner is at its final pressure, but the nut cannot be loosened.
- A:** If the nuts cannot be loosened at the final pressure, continually increasing the pressure will not help and can be dangerous and in some cases make it harder to remove the nut. Check the nut to see if its set screws have been loosened. Check for and remove any corrosion around the nut's threads. Apply penetrating oil between the stud and the nut.
- Q:** How do I clean the conical threads on a stud?
- A:** The conical threads are best cleaned using a spiral wound brass brush in a drill as described in section 5.2.2
- Q:** During the initial steps of removing a tensioned stud, the stick-out length is found to be wrong.
- A:** Do not proceed. Contact Riverhawk for assistance. With the wrong stick-out length, the hydraulic tensioner has a limited stroke and may not work properly and can be damaged.
- Q:** The hydraulic pump appears to be leaking.
- A:** Check the hose connection to the hydraulic pump. If the 1/4" high pressure fitting is not assembled correctly as shown in section 7.2, it may look like the pump is leaking. If the problem continues, it may be necessary to open the pump kit. Contact Riverhawk for guidance.
- Q:** The hydraulic hose has a collar on it that can't be moved by hand
- A:** The hydraulic fitting is shown in section 7.2. The collar is sometimes held in place with a thread locking compound. This prevents the collar from moving too easily. It may be necessary to adjust this collar with a set of vise-grip pliers. Be careful to not strip the threads off the tube or hose end.



215 Clinton Road
New Hartford, NY 13413
Tel: +1 315 768 4855
Fax: +1 315 768 4941
Email: info@riverhawk.com

CUSTOMER'S INFORMATION BOX
CONTENTS ARE INDEPENDENT OF RIVERHAWK DOCUMENT CONTROL

GE DRAWING NUMBER	REV
373A4078	

14.0 Revision History

Revision Letter	Effective Date	Description
G	Apr 3, 2023	Added 306T4564 to title page and section 2
F	Jul 15, 2022	Revised figures 6A and 6B in section 6; Inserted Appendix B1
E	Jan 27, 2022	Updated EC Declaration of Conformity; Added UKCA Declaration of Conformity
D	Aug 13, 2019	Added 133T8375 to title page; Inserted sections 2.1, 2.2, and 2.3
C	Nov 20, 2018	Added 131T2640 to title page; Inserted sections 2.1, 2.2, and 2.3; Insert Picture 6D
B	Sep 28, 2017	Added 381A6850P021, P022, and P023 to the title page and section 2
A	Sep 29, 2016	Relocated instructions related to Load Gear to Generator connection and tensioner HT-6754 to IM-406 (GE 373A4099)
-	Mar 27, 2015	Released



215 Clinton Road
 New Hartford, NY 13413
 Tel: +1 315 768 4855
 Fax: +1 315 768 4941
 Email: info@riverhawk.com

CUSTOMER'S INFORMATION BOX
 CONTENTS ARE INDEPENDENT OF RIVERHAWK DOCUMENT CONTROL

GE DRAWING NUMBER	REV
373A4078	

Appendix A1

EC Declaration of Conformity

Manufacturer: Riverhawk Company
Address: 215 Clinton Road
New Hartford, NY 13413, USA

The hydraulic pump and bolt tensioning tool described in this manual are used for installing and applying tension to large bolts that are specifically designed by Riverhawk Company to be tensioned hydraulically.

All applicable sections of European Directive 2006/42/EC for machinery have been applied and fulfilled in the design and manufacture of the hydraulic pump and bolt tensioning tool described in this manual. Reference also ISO 12100:2010, ISO 4413:2010, and ISO 4414:2010.

Furthermore, this equipment has been manufactured under the Riverhawk quality system per EN ISO 9001:2015

Consult the Declaration of Conformance included with the shipment of this equipment that identifies the authorized Riverhawk representative, applicable serial numbers, and appropriate signature.



215 Clinton Road
New Hartford, NY 13413
Tel: +1 315 768 4855
Fax: +1 315 768 4941
Email: info@riverhawk.com

CUSTOMER'S INFORMATION BOX
CONTENTS ARE INDEPENDENT OF RIVERHAWK DOCUMENT CONTROL

GE DRAWING NUMBER	REV
373A4078	

Appendix A2

UKCA Declaration of Conformity

Manufacturer: Riverhawk Company
Address: 215 Clinton Road
New Hartford, NY 13413, USA

The hydraulic pump and bolt tensioning tool described in this manual are used for installing and applying tension to large bolts that are specifically designed by Riverhawk Company to be tensioned hydraulically.

All applicable sections of Supply of Machinery (Safety) 2008 have been applied and fulfilled in the design and manufacture of the hydraulic pump and bolt tensioning tool described in this manual. Reference also ISO 12100:2010, ISO 4413:2010, and ISO 4414:2010.

Furthermore, this equipment has been manufactured under the Riverhawk quality system per EN ISO 9001:2015

Consult the Declaration of Conformance included with the shipment of this equipment that identifies the authorized Riverhawk representative, applicable serial numbers, and appropriate signature.



215 Clinton Road
New Hartford, NY 13413
Tel: +1 315 768 4855
Fax: +1 315 768 4941
Email: info@riverhawk.com

CUSTOMER'S INFORMATION BOX
CONTENTS ARE INDEPENDENT OF RIVERHAWK DOCUMENT CONTROL

GE DRAWING NUMBER	REV
373A4078	

Appendix B1 - Hydraulic Fittings

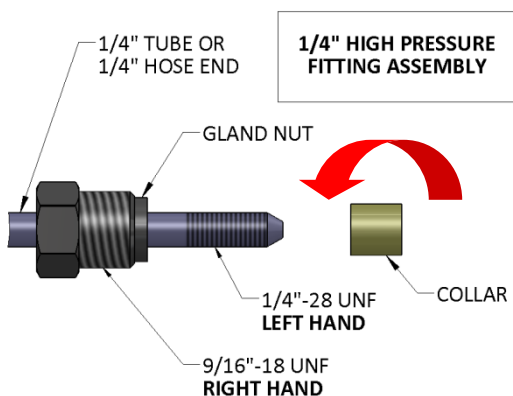

Illustration 1

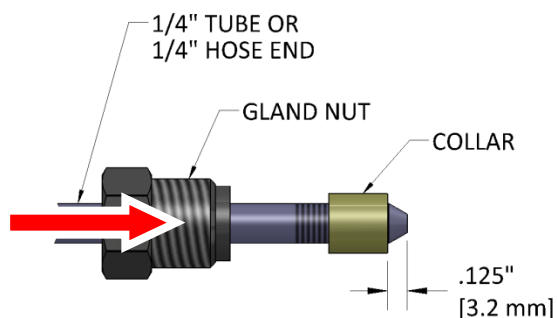

Illustration 2

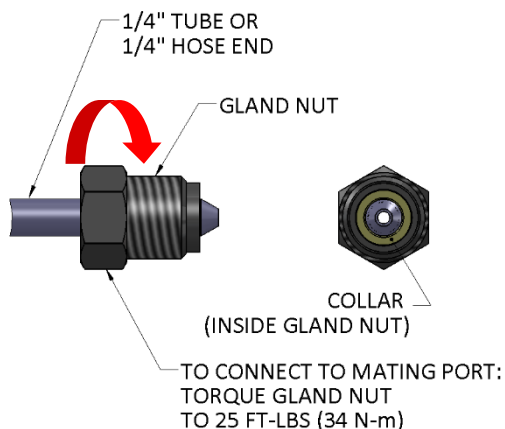

Illustration 3

Riverhawk tensioners use a 1/4" High Pressure port to connect its hydraulic hoses. The hose connector is made from a three piece assembly: a gland nut, a collar, and a 1/4" tube or 1/4" hose end. (See Illustration 1)

To assembly the fitting, slide the gland nut over the 1/4" tube or 1/4" hose end. Turn the collar counter-clockwise (**left hand** thread) on to the tube or hose end as shown in Illustration 1.

The collar should be placed .125" (3.2 mm) from the tip of the cone. (See Illustration 2) It may be necessary to adjust this collar with a set of vise-grip pliers. Be careful to not strip the threads off the tube or hose end.

Slide the gland nut down over the collar. (See Illustration 3) Insert the 1/4" tube or 1/4" hose end into tensioner or hydraulic pump. While firmly holding the tube or hose end to stop it from rotating, turn the gland nut clockwise (**right hand** thread) and torque the gland nut to 25 FT-LBS (34 N-m).

Tips:

- Make sure all parts are clean and free from debris.
- Protect the cone on the end of the 1/4" tube or 1/4" hose end from scratches as this is the sealing surface.
- Replace red plastic caps when finished to protect the threads and cone.



215 Clinton Road
 New Hartford, NY 13413
 Tel: +1 315 768 4855
 Fax: +1 315 768 4941
 Email: info@riverhawk.com

CUSTOMER'S INFORMATION BOX	
CONTENTS ARE INDEPENDENT OF RIVERHAWK DOCUMENT CONTROL	
GE DRAWING NUMBER	REV
373A4078	

Appendix C1

STRETCH RECORD SHEET FOR
THE GAS TURBINE TO LOAD COUPLING

TURBINE NUMBER:

DATE:

TECHNICIAN:

SUPERVISOR:

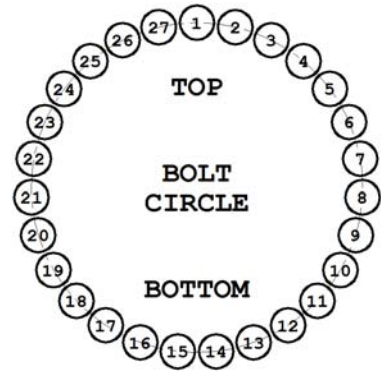

Hole Number	Starting Length	Final Length	Final Stretch
1			
14			
2			
15			
3			
16			
4			
17			
5			
18			
6			
19			
7			
20			
8			
21			
9			
22			
10			
23			
11			
24			
12			
25			
13			
26			
27			

CUSTOMER'S INFORMATION BOX

CONTENTS ARE INDEPENDENT OF RIVERHAWK DOCUMENT CONTROL

GE DRAWING NUMBER	REV
373A4078	



215 Clinton Road
New Hartford, NY 13413
Tel: +1 315 768 4855
Fax: +1 315 768 4941
Email: info@riverhawk.com

Appendix C2

STRETCH RECORD SHEET FOR
THE LOAD COUPLING TO GEARBOX

TURBINE NUMBER:

DATE:

TECHNICIAN:

SUPERVISOR:

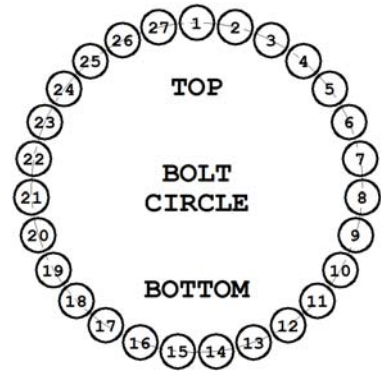

Hole Number	Starting Length	Final Length	Final Stretch
1			
14			
2			
15			
3			
16			
4			
17			
5			
18			
6			
19			
7			
20			
8			
21			
9			
22			
10			
23			
11			
24			
12			
25			
13			
26			
27			

CUSTOMER'S INFORMATION BOX

CONTENTS ARE INDEPENDENT OF RIVERHAWK DOCUMENT CONTROL

GE DRAWING NUMBER	REV
373A4078	



215 Clinton Road
New Hartford, NY 13413
Tel: +1 315 768 4855
Fax: +1 315 768 4941
Email: info@riverhawk.com