



**INSTRUCTION MANUAL IM-269**  
**For Gas Turbine Tensioned Studs and Nuts**

**Fr.9FA Turbine to HITACHI Generator GE102T5689P001  
 GE102T5689P002**

**Fr. 9FA Turbine to Load Coupling GE102T5689P004**

**Load Coupling to HITACHI Generator GE102T5689P005**

**CUSTOMER'S INFORMATION BOX**

CONTENTS ARE INDEPENDENT OF RIVERHAWK DOCUMENT CONTROL

<b>GE Power &amp; Water</b>		GENERAL ELECTRIC COMPANY	
<b><u>VENDOR SUPPLIED</u></b>			
GE NOT TO REVISE. GE REVISION LEVEL IS SHOWN ON THIS APPLIQUE. THIS DOCUMENT IS FILED UNDER THE GE DRAWING NUMBER.			
THIS DOCUMENT SHALL BE REVISED IN ITS ENTIRETY. ALL SHEETS OF THIS DOCUMENT ARE THE SAME REVISION LEVEL AS INDICATED IN THIS VENDOR SUPPLIED DRAWING APPLIQUE.			
MLI: _____ OF _____			
GE SIGNATURES	DATE	GE DRAWING NUMBER	REV
CHECKED:		<b>373A4004</b>	
ISSUED:			

The Riverhawk Company reserves the right to make changes updating this document without dissemination or notice. The latest revision level may be obtained by contacting Riverhawk Company directly or visit our website at [www.riverhawk.com](http://www.riverhawk.com)



Repairs – Rentals  
 Field Service

215 Clinton Road  
 New Hartford, NY 13413  
 Tel: +1 315 768 4855  
 Fax: +1 315 768 4941  
 Email: [info@riverhawk.com](mailto:info@riverhawk.com)

**Table of Contents**

Section	Description	Page Number
1.0	Cautions and Safety Warnings	3
2.0	Scope	3
3.0	Quick Check-List	4
4.0	General Preparations	6
5.0	Hardware Set Preparations	8
6.0	Stud and Nut Assembly	10
7.0	Assembly of Hydraulic Tensioner Equipment	12
8.0	Assembly of Tensioner on Stud	15
9.0	Stud Tensioning	20
10.0	Thread Locking	22
11.0	Windage Plug Installation	23
12.0	Stud and Nut Removal	25
13.0	Storage Instructions	27
14.0	Frequently Asked Questions	29
15.0	Revision History	31
Appendix A1	EC Declaration of Conformity	32
Appendix A2	UKCA Declaration of Conformity	33
Appendix B1	Turbine Side Stretch Record Sheet	34
Appendix B2	Generator Side Stretch Record Sheet	35



215 Clinton Road  
 New Hartford, NY 13413  
 Tel: +1 315 768 4855  
 Fax: +1 315 768 4941  
 Email: info@riverhawk.com

**CUSTOMER'S INFORMATION BOX**  
 CONTENTS ARE INDEPENDENT OF RIVERHAWK DOCUMENT CONTROL

GE DRAWING NUMBER	REV
373A4004	

## 1.0 Cautions and Safety Warnings

### CAUTION

Personal injury and equipment damage can occur if the puller screw is not securely engaged with the tapered thread of the stud. Proper engagement is achieved when the puller screw is tight in the stud and the Tensioner Assembly is free to rotate.

### CAUTION

The “9FA gas turbine to the load coupling” flange uses a different tensioner than the “load coupling to HITACHI generator” flange. Verify the correct tensioner is being used.

### WARNING

The safety cage MUST be in place and hands kept out of designated areas at all times when the tensioner is pressurized otherwise personal injury can occur.

### CAUTION

DO NOT EXCEED THE MAXIMUM PRESSURE VIBROSCRIBED ON THE PULLER BODY. Excessive pressure can damage the stud and the puller screw.

### CAUTION

DO NOT EXCEED THE MAXIMUM PRESSURE VIBROSCRIBED ON THE PULLER BODY. Excessive pressure can damage the stud and puller screw

**Note:** Before threading the puller screw into the stud, carefully check the cleanliness of both the stud's and the puller screw's conical threads. Be sure to remove all dirt from the root of the studs' conical threads. Apply a light coat of clean turbine oil or a spray lubricant to the puller screw. Do not use “Never Seize” on the conical threads. This procedure will ease assembly and assure positive mating of the threads before tightening.

## 2.0 Scope

This document describes the procedure to be used to install studs and nuts supplied by Riverhawk Company in the flanges at the turbine/coupling and coupling/generator connections. This hardware is depicted on the following drawings. These drawings as well as Tooling drawings form a part of this manual.

### Hardware Sets:

HF-5376 HF-5458 HF-5459

### Hydraulic Tensioners:

HT-0445 HT-5407



215 Clinton Road  
New Hartford, NY 13413  
Tel: +1 315 768 4855  
Fax: +1 315 768 4941  
Email: info@riverhawk.com

### CUSTOMER'S INFORMATION BOX CONTENTS ARE INDEPENDENT OF RIVERHAWK DOCUMENT CONTROL

GE DRAWING NUMBER	REV
373A4004	

### 3.0 Quick Checklist

The following checklist is intended as a summary of the steps needed to use the Riverhawk-supplied equipment. New personnel or those experienced personnel who have not used the Riverhawk equipment recently are encouraged to read the entire manual.

#### EQUIPMENT INSPECTION

- Check oil level in hydraulic pump.
- Check air pressure at 80 psi [5.5 bar] minimum. (For air-driven pumps)
- Check hydraulic hose for damage.
- Test pump.
- Inspect tensioner for any damage.

#### NUT AND STUD PREPARATION

- Inspect stud and nuts for any damage.
- Measure stud length.
- Clean the studs and nuts.
- Install studs and nuts (off-center) into the flange.
- Set stick-out dimension on the coupling side of the flange.
- Hand tighten all studs.
- Verify stick-out measurement (VERY IMPORTANT)



215 Clinton Road  
New Hartford, NY 13413  
Tel: +1 315 768 4855  
Fax: +1 315 768 4941  
Email: info@riverhawk.com

**CUSTOMER'S INFORMATION BOX**  
CONTENTS ARE INDEPENDENT OF RIVERHAWK DOCUMENT CONTROL

GE DRAWING NUMBER	REV
373A4004	

**Tensioning (Bolt installation)**

- Match the tensioner setup to the flange joint.
- Apply a light coat of clean turbine oil or spray lubricant to the puller screw. **DO NOT USE "NEVER SEIZE" ON THE CONICAL THREADS.**
- Slide spanner ring over the puller screw.
- Mount the tensioner on the stud in flange.
- Install spanner ring onto nut.
- Insert 1/2" hex Allen wrench into the back side of the stud.
- Tighten the puller screw.
- Back off puller screw 1/2 turn.
- Retighten the puller screw and leave tight. **DO NOT BACK OFF PULLER SCREW.**
- Bleed the tensioner. **Do NOT bleed tensioner off of a stud! Damage to the tool will result!**
- Tension to 50%. Consult manual for correct pressure.
- Use the pin wrench in spanner ring to tighten nut.
- Release pressure, move to next stud in pattern.
- Repeat above steps at final pressure.
- Measure final stud length and record on stretch datasheets. Calculate stretch.
- Torque nuts' set screws.



215 Clinton Road  
New Hartford, NY 13413  
Tel: +1 315 768 4855  
Fax: +1 315 768 4941  
Email: info@riverhawk.com

**CUSTOMER'S INFORMATION BOX**  
CONTENTS ARE INDEPENDENT OF RIVERHAWK DOCUMENT CONTROL

GE DRAWING NUMBER	REV
373A4004	

**Detensioning (Stud removal)**

- Loosen nuts' set screws
- Inspect and clean studs' conical threads. **Do not continue until ALL debris is removed from the threads! Do not try to use the tensioner to remove a damaged stud!**
- Apply a light coat of clean turbine oil or spray lubricant to the puller screw. **DO NOT USE "NEVER SEIZE" ON THE CONICAL THREADS.**
- Slide spanner ring over the puller screw.
- Mount the tensioner on the stud.
- Install spanner ring into nut.
- Tighten the puller screw.
- Back off puller screw 1/2 a turn.
- Retighten the puller screw and leave tight. **DO NOT BACK OFF PULLER SCREW.**
- Bleed the tensioner. **Do NOT bleed tensioner off of a stud! Damage to the tool will result!**
- Apply final pressure.
- Loosen nut with the spanner ring and pin wrench.
- Move to next stud in pattern

**4.0 General Preparations**

**Read and understand all instructions before installing and tensioning studs.**

This equipment produces very high hydraulic pressures and very high forces. Operators must exercise caution, wear safety glasses and hard hats when using this equipment.

High pressure fluid from the Hydraulic Pressure Kit system pressurizes the tensioner which generates a stretching force that actually stretches the stud. As the stud is stretched the nut lifts off the flange. The nut is then reseated into position on the flange by turning a nut driver



215 Clinton Road  
New Hartford, NY 13413  
Tel: +1 315 768 4855  
Fax: +1 315 768 4941  
Email: info@riverhawk.com

**CUSTOMER'S INFORMATION BOX**  
CONTENTS ARE INDEPENDENT OF RIVERHAWK DOCUMENT CONTROL

GE DRAWING NUMBER	REV
373A4004	

by hand. When the nut is tight against the flange, the pressure in the tensioner is released leaving the stud loaded to its predetermined value.

#### 4.1 Machine Preparation

The flange to be tensioned must be **fully closed prior to positioning** the studs in the flanges. Also, it will be advantageous to remove as many obstructions as possible from the flange area, such as speed probes and conduit.

#### 4.2 Hardware – Balance

- Hardware is supplied as weight balanced sets
- Studs and nuts are interchangeable within sets
- Do not intermix with other sets
- Save weight certification supplied with each set for the purchase of spare parts

#### 4.3 Tensioner – Care and Handling

- When not in use, the tensioner shall be maintained in a clean environment and all caps and plugs for hydraulic openings and fittings must be in place.
- When in use, the tensioner shall be protected from sand and grit.
- Long term storage – coat tensioner with oil, return to original container, seal container and protect from moisture. **DO NOT STORE OUTSIDE**
- Shipment – coat tensioner with oil and ship in original container.

#### 4.4 Hand Tools

Several hand wrenches and micrometers will be required to perform installation and measurement of the studs:

- 5/8" wrench
- 1" wrench
- 1" Socket and Impact Wrench
- A set of Allen Wrenches
- 3' – 4' Breaker Bar
- 12" to 13" micrometer or caliper



215 Clinton Road  
New Hartford, NY 13413  
Tel: +1 315 768 4855  
Fax: +1 315 768 4941  
Email: info@riverhawk.com

**CUSTOMER'S INFORMATION BOX**  
CONTENTS ARE INDEPENDENT OF RIVERHAWK DOCUMENT CONTROL

GE DRAWING NUMBER	REV
373A4004	

## 4.5 Special Tools

Hydraulic Tensioner Kit: HT-0445 Hydraulic Tensioner  
**GAS TURBINE SIDE ONLY**  
(reference GE 359B2507)

HT-5407 Hydraulic Tensioner  
**GENERATOR SIDE ONLY**  
(reference GE 269B8709)

Hydraulic Pump Kit: AP-0532 Air-Operated Hydraulic Pump  
(recommended)  
(reference GE 359B2502)

MP-0130 Manual Hand-Operated  
Hydraulic Pump  
(reference GE 359B2506)

## 5.0 Hardware Set Preparations

### 5.1 Nut Preparation

For new installations, the nuts should come sealed from the factory and will need no cleaning.

Previously installed nuts require cleaning: Wire brush using a petroleum-based solvent to remove any foreign material on the external surfaces and threads.

**Do not apply thread lubricants to the threads.**

Finish the cleaning process by rinsing in a volatile solvent such as acetone and allow to dry.

### 5.2 Stud Preparation

For new installations, the studs should come sealed from the factory and will need no cleaning.



215 Clinton Road  
New Hartford, NY 13413  
Tel: +1 315 768 4855  
Fax: +1 315 768 4941  
Email: info@riverhawk.com

**CUSTOMER'S INFORMATION BOX**  
CONTENTS ARE INDEPENDENT OF RIVERHAWK DOCUMENT CONTROL

GE DRAWING NUMBER	REV
373A4004	

Revision C  
Page 8 of 35



### 5.2.1 Stud Cleaning - Old Installations

Previously installed studs may require cleaning. Clean conical threads should have a bright and shiny appearance.

If cleaning is required, follow these steps:

1. Blow out the threads with compressed air to remove loose debris and dry conical threads. Do not apply a solvent or other cleaning solution to the threads as this may chemically attack the stud.
2. Use Stud Cleaning Kit, GT-4253 or a similar 1" diameter Brass power brush.



Picture of Brass Power Brush

3. Insert the brush into an electric drill and set drill to run in a counterclockwise direction at high speed.
4. Work the drill in a circular motion while moving the brush in and out to clean all of the threads. Try not to hold the brush in one place too long, so as not to remove the stud's protective coating.
5. Blow out the threads with compressed air to remove loosened debris.
6. Visually inspect threads for cleanliness. Threads should be bright and shiny.
7. Repeat if any dirt can be seen in the threads.
8. Inspect threads for any damage that may have been caused by previous installation.

**Do not apply thread lubricants to the threads.**

Finish the cleaning process by rinsing in a volatile solvent such as acetone and allow to dry.



215 Clinton Road  
New Hartford, NY 13413  
Tel: +1 315 768 4855  
Fax: +1 315 768 4941  
Email: info@riverhawk.com

**CUSTOMER'S INFORMATION BOX**  
CONTENTS ARE INDEPENDENT OF RIVERHAWK DOCUMENT CONTROL

GE DRAWING NUMBER	REV
373A4004	

Revision C  
Page 9 of 35

### 5.3 Stud Length Measurement

Stud measurement will require a micrometer or caliper, which will measure 12" to 13" (304.8 mm to 330.2 mm).

Measure and record the initial length of the studs. The following suggestions will improve your results:

- **Plan to start and finish any flange in the same day.**
- **Studs and flange must be at the same temperature.**
- **Number each stud with a marker.**
- **Mark the location of measurement on stud end with a permanent marker.**
- **Measure each stud to nearest 0.001" (.02 mm).**
- **Record each measurement on the supplied charts.**
- **Do not allow the micrometer to set in the sun.**

### 6.0 Stud and Nut Assembly

Refer to Hardware Assembly Drawing (HF-) listed in Section 2.0 of this manual.

1. Before threading the nut onto the stud check to be certain that the set screws are free to turn.
2. Assemble front-side nut to the tapered thread end (Pull End) of the stud. Please note that the front and back side nuts are different.
3. Slide the stud and nut assembly into the flange from the coupling side as shown in Figures 1 and 2.
4. Install the nut on the back-side of the flange. Please note that the front and back side nuts are different.
5. **Adjust the nut/stud assembly so that the stud protrudes from the face of the cylindrical nut by the amount depicted on the hardware drawing (from section 2) and shown in Figures 1 and 2. SETTING THIS PROTRUSION (or stick-out) OF STUD TO NUT IS CRITICAL FOR PROPER TENSIONER OPERATION. A metal stick-out gage is provided with the tensioner to assist the operator in setting the protrusion dimension (See Figure 3 for this and other methods).**



215 Clinton Road  
New Hartford, NY 13413  
Tel: +1 315 768 4855  
Fax: +1 315 768 4941  
Email: info@riverhawk.com

CUSTOMER'S INFORMATION BOX  
CONTENTS ARE INDEPENDENT OF RIVERHAWK DOCUMENT CONTROL

GE DRAWING NUMBER	REV
373A4004	

Revision C  
Page 10 of 35

- Hand tighten the back-side nut, without turning the stud or front-side nut, to a snug fit.

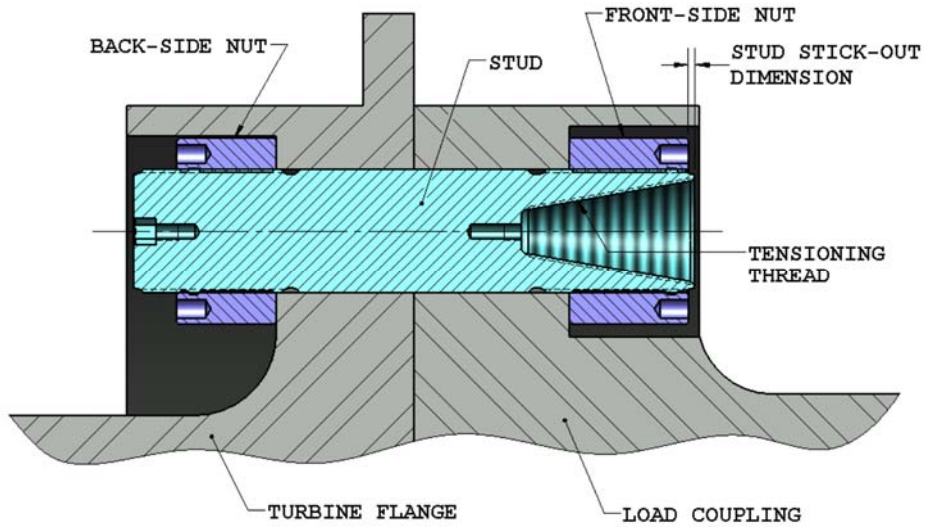

Figure 1 – Cutaway View of Turbine Flange to Load Coupling Bolted Joint

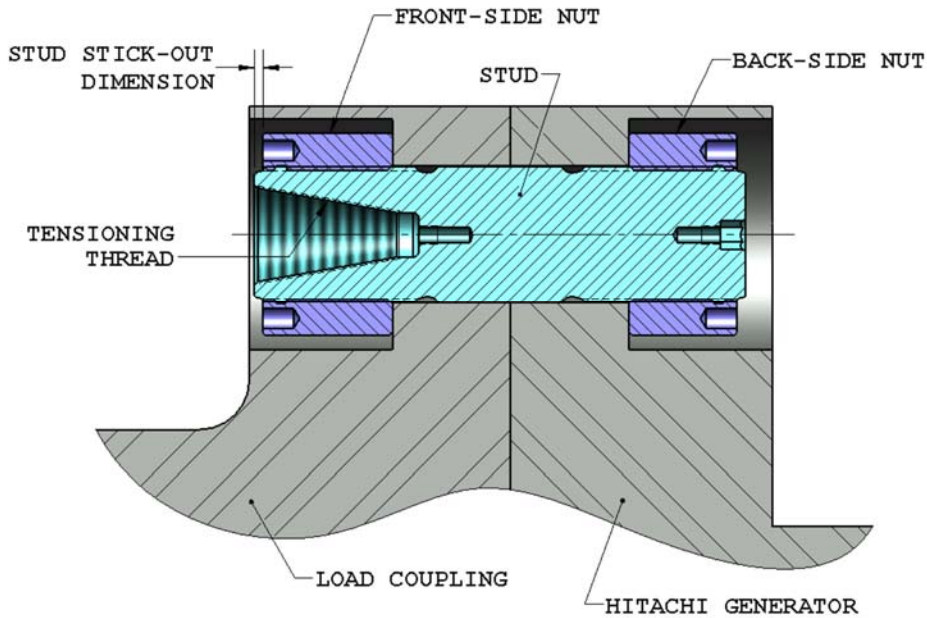

Figure 2 – Cutaway View of Load Coupling to Hitachi Generator Bolted Joint



215 Clinton Road  
 New Hartford, NY 13413  
 Tel: +1 315 768 4855  
 Fax: +1 315 768 4941  
 Email: info@riverhawk.com

CUSTOMER'S INFORMATION BOX  
 CONTENTS ARE INDEPENDENT OF RIVERHAWK DOCUMENT CONTROL

GE DRAWING NUMBER	REV
373A4004	



Stick-Out Gage



Drop Gage

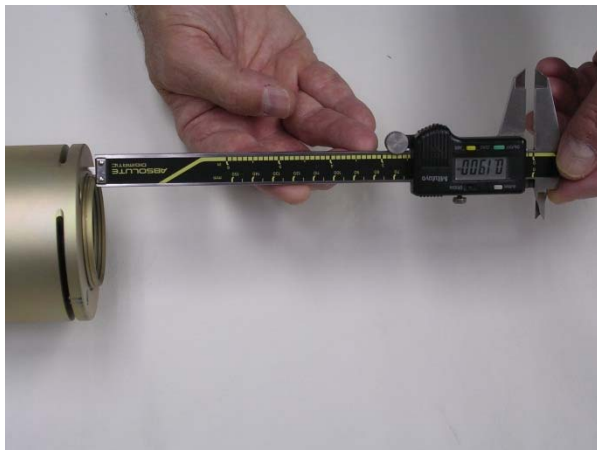

Digital Calipers

Figure 3 – Pictures of a Stick-Out Measurement Methods

## 7.0 Assembly of Hydraulic Tensioner Equipment

### 7.1 Check Hydraulic Equipment

#### 7.1.1 Check Hydraulic Tensioners

Clean puller screw and check for any debris and dents.



215 Clinton Road  
New Hartford, NY 13413  
Tel: +1 315 768 4855  
Fax: +1 315 768 4941  
Email: info@riverhawk.com

CUSTOMER'S INFORMATION BOX  
CONTENTS ARE INDEPENDENT OF RIVERHAWK DOCUMENT CONTROL

GE DRAWING NUMBER	REV
373A4004	

Revision C  
Page 12 of 35

Puller screw should be free to rotate and move back and forth.

Seam between cylinders closed tightly.

Inspect tensioner guard for any signs of damage. Bent guards should be replaced. Also, be sure the rubber pad is in place on the end of the guard, if missing, replace.

### 7.1.2 Check Hydraulic Pump Kit

The pump kit is shipped full of hydraulic oil. The pump reservoir cap is sealed for shipment.

Replace the grey shipping cap with the red plastic reservoir cap.

To use the pump, turn cap to the vent position and follow the operating instructions on the inside cover.

To prevent oil spillage, close cap when not in use. Lost oil should be replaced with Enerpac Hydraulic Oil. ISO 32 or equivalent hydraulic oil may be substituted.

Test pump by dead-heading (leave port plug in place) and run pump – should hold steady pressure.

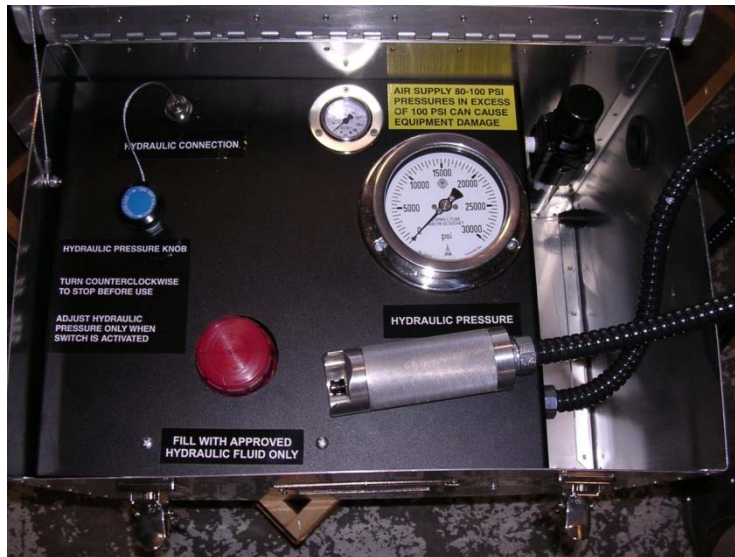

Sample Picture of AP-0532 Hydraulic Pump with hydraulic connection plugged for testing



215 Clinton Road  
New Hartford, NY 13413  
Tel: +1 315 768 4855  
Fax: +1 315 768 4941  
Email: info@riverhawk.com

**CUSTOMER'S INFORMATION BOX**  
CONTENTS ARE INDEPENDENT OF RIVERHAWK DOCUMENT CONTROL

GE DRAWING NUMBER	REV
373A4004	

## 7.2 Hydraulic Fittings

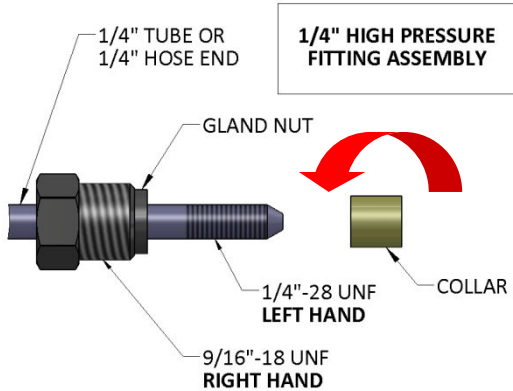

Illustration 1

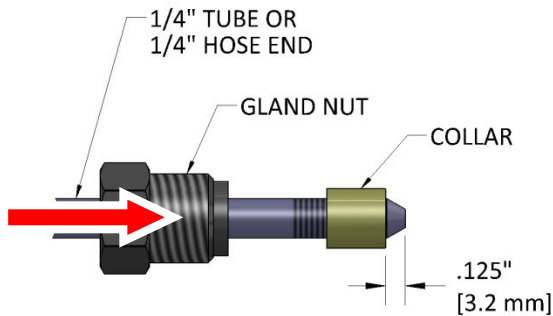

Illustration 2

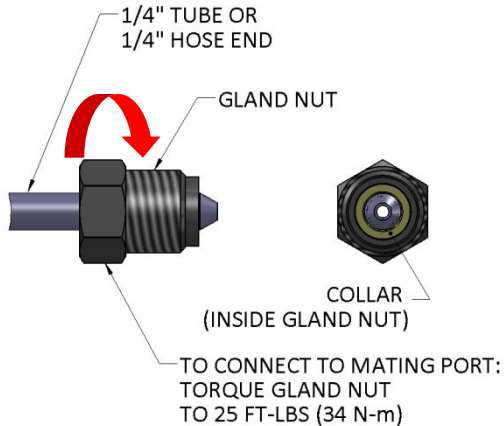

Illustration 3

Riverhawk hydraulic pumps use a 1/4" High Pressure port to connect its hydraulic hoses. The hose connector is made from a three piece assembly: a gland nut, a collar, and a 1/4" tube or 1/4" hose end. (See Illustration 1)

To assembly the fitting, slide the gland nut over the 1/4" tube or 1/4" hose end. Turn the collar counter-clockwise (**left hand** thread) on to the tube or hose end as shown in Illustration 1.

The collar should be placed .125" (3.2 mm) from the tip of the cone. (See Illustration 2) It may be necessary to adjust this collar with a set of vise-grip pliers. Be careful to not strip the threads off the tube or hose end.

Slide the gland nut down over the collar. (See Illustration 3) Insert the 1/4" tube or 1/4" hose end into the tensioner's quick coupler. While firmly holding the tube or hose end to stop it from rotating, turn the gland nut clockwise (**right hand** thread) and torque the gland nut to 25 FT-LBS (34 N-m).

### Tips:

- Make sure all parts are clean and free from debris.
- Protect the cone on the end of the 1/4" tube or 1/4" hose end from scratches as this is the sealing surface.
- Replace red plastic caps when finished to protect the threads and cone.



215 Clinton Road  
New Hartford, NY 13413  
Tel: +1 315 768 4855  
Fax: +1 315 768 4941  
Email: info@riverhawk.com

### CUSTOMER'S INFORMATION BOX

CONTENTS ARE INDEPENDENT OF RIVERHAWK DOCUMENT CONTROL

GE DRAWING NUMBER	REV
373A4004	

## 8.0 Assembly of Tensioner on Stud

### **CAUTION**

The “9FA gas turbine to the load coupling” flange uses a different tensioner than the “load coupling to HITACHI generator” flange. Verify the correct tensioner is being used

Riverhawk tensioner **HT-0445** is for the **GAS TURBINE SIDE ONLY**.

Riverhawk tensioner **HT-5407** is for the **GENERATOR SIDE ONLY**.

## 8.1 Handling of the Tensioner

Rest the tensioner on top of the coupling shaft. Using a strap just long enough to go around the coupling shaft, attach each end to the handles of the tensioner. One way to do this is to attach the strap by looping the strap through itself and around the handle of the tensioner on one side then around the coupling shaft and finally attached to the handle on the other side with a D-shackle. This will help hold the tensioner in place should it fall off of the shaft. The strap also helps the operators move the tensioner around the shaft while tensioning.

If possible, use a ‘Come-along’ or chain fall from the ceiling of the coupling room and attach it to the tensioner using a short strap wrapped through the handles and around the top of the tensioner. This will allow the operators to easily move the tensioner around the coupling shaft by supporting the weight of the tool.

## 8.2 Kit Assembly

Assemble the hydraulic pump with its hose to the tensioner and bleed out the air per following instructions in section 8.3.



215 Clinton Road  
New Hartford, NY 13413  
Tel: +1 315 768 4855  
Fax: +1 315 768 4941  
Email: info@riverhawk.com

### **CUSTOMER'S INFORMATION BOX** CONTENTS ARE INDEPENDENT OF RIVERHAWK DOCUMENT CONTROL

GE DRAWING NUMBER	REV
373A4004	

Revision C  
Page 15 of 35



Sample picture showing hose attached to a tensioner

**Note:** Before threading the puller screw into the stud, carefully check the cleanliness of both the stud's and the puller screw's conical threads. Apply a light coat of clean turbine oil or a spray lubricant to the puller screw. Do not use "Never Seize" on the conical threads. This procedure will ease assembly and assure positive mating of the threads before tightening.

Refer to Tensioner Assembly drawing and photo for views of the tensioner to flange mounting. All tensioning will be performed on the coupling side of the flange connections.



215 Clinton Road  
New Hartford, NY 13413  
Tel: +1 315 768 4855  
Fax: +1 315 768 4941  
Email: info@riverhawk.com

**CUSTOMER'S INFORMATION BOX**  
CONTENTS ARE INDEPENDENT OF RIVERHAWK DOCUMENT CONTROL

GE DRAWING NUMBER	REV
373A4004	



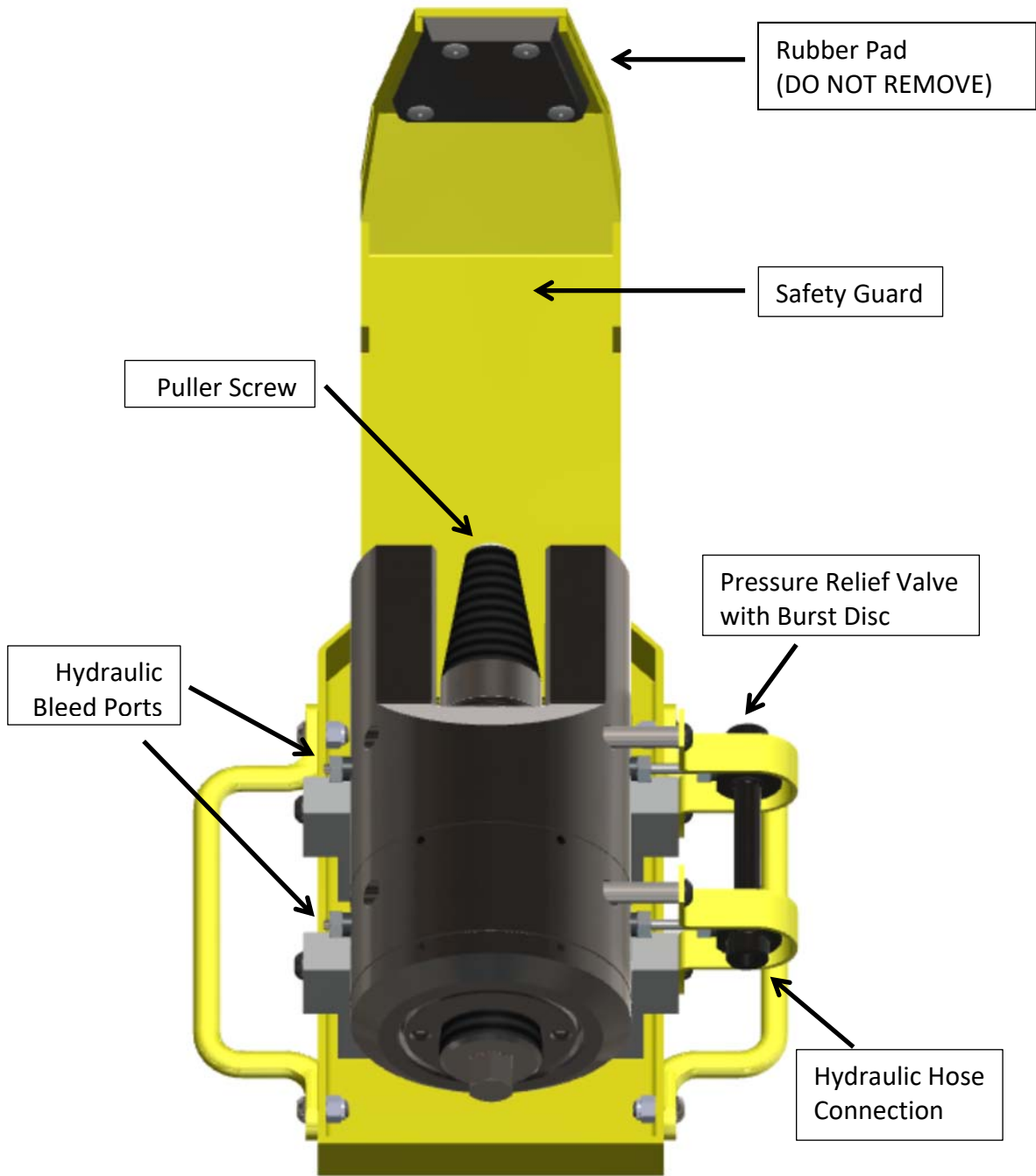

Figure of HT-0445 Tensioner



215 Clinton Road  
New Hartford, NY 13413  
Tel: +1 315 768 4855  
Fax: +1 315 768 4941  
Email: info@riverhawk.com

**CUSTOMER'S INFORMATION BOX**  
CONTENTS ARE INDEPENDENT OF RIVERHAWK DOCUMENT CONTROL

GE DRAWING NUMBER	REV
373A4004	

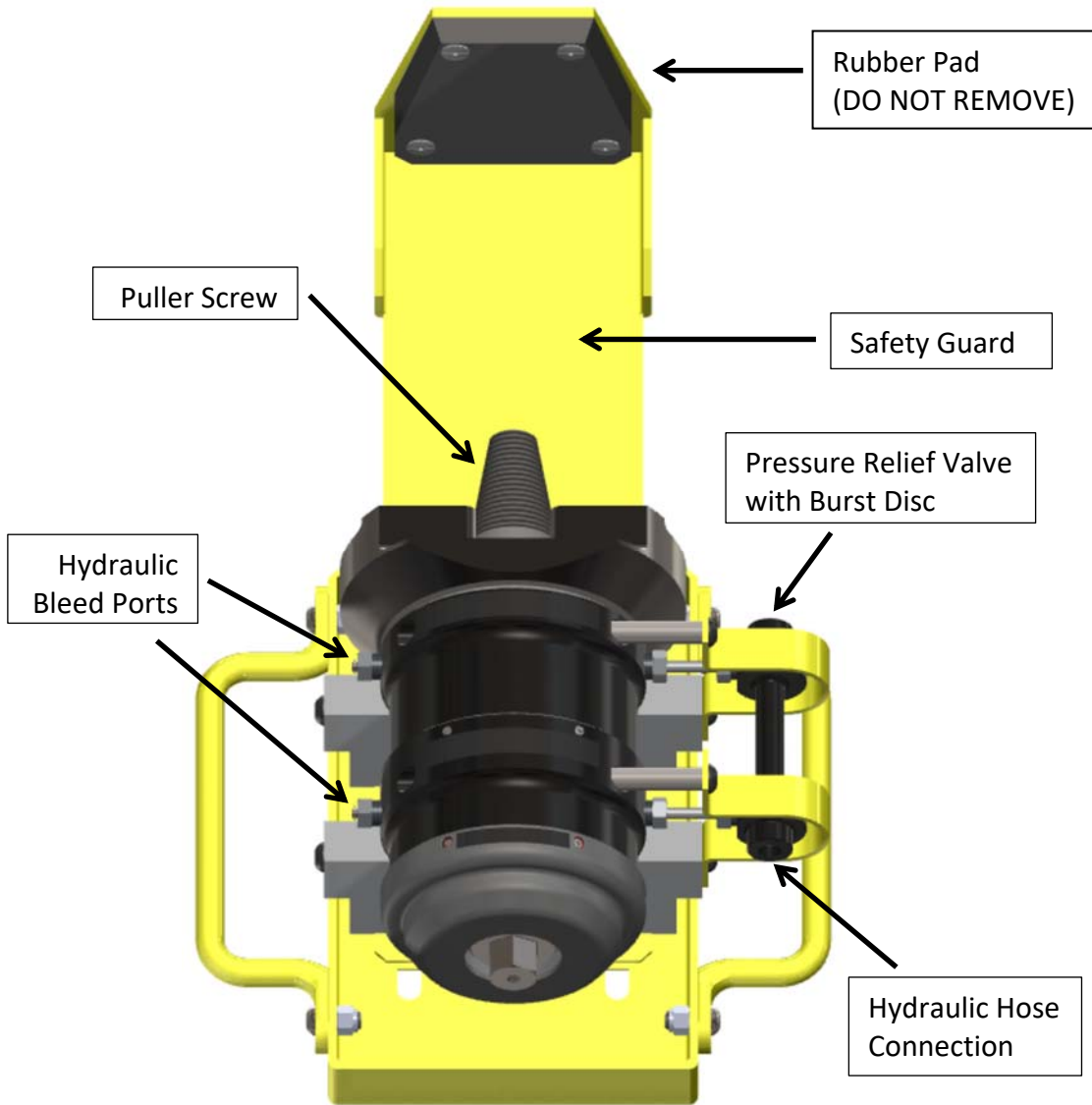

Figure of HT-5407 Tensioner



215 Clinton Road  
New Hartford, NY 13413  
Tel: +1 315 768 4855  
Fax: +1 315 768 4941  
Email: info@riverhawk.com

**CUSTOMER'S INFORMATION BOX**  
CONTENTS ARE INDEPENDENT OF RIVERHAWK DOCUMENT CONTROL

GE DRAWING NUMBER	REV
373A4004	

Assembly sequence is as follows:

- Place the spanner ring (different for each end turbine or generator) over the puller screw on the tensioner.
- Place and hold the tensioner assembly over the end of the stud to be tightened.



- Slide the puller screw in to the tapered thread of the stud and hand tighten. **Be sure not to cross thread assembly.**
- Hold the stud steady with a 1/2" hex key wrench and lightly tighten the puller screw into the conical thread of the stud with a wrench.
- Place the spanner ring on the cylindrical nut located on the stud.
- At this point the Tensioner Assembly **MUST BE FREE TO ROTATE**, the puller screw must be tight in the stud. **DO NOT BACK OFF PULLER SCREW.**

If the tensioner is not free to rotate when the puller screw is tight then, either (1) the stud is not properly positioned in the flange and recheck the stick-out length and reposition the nuts, or (2) The tensioner is damaged and must be returned for repair.

### CAUTION

Personal injury and equipment damage can occur if the puller screw is not securely engaged with the tapered thread of the stud. Proper engagement is achieved when the puller screw is tight in the stud and the Tensioner Assembly is free to rotate.

### 8.3 Bleeding Hydraulic System

Follow the tensioner assembly instructions of Section 8.0



215 Clinton Road  
 New Hartford, NY 13413  
 Tel: +1 315 768 4855  
 Fax: +1 315 768 4941  
 Email: info@riverhawk.com

CUSTOMER'S INFORMATION BOX  
 CONTENTS ARE INDEPENDENT OF RIVERHAWK DOCUMENT CONTROL

GE DRAWING NUMBER	REV
373A4004	

**TO AVOID FAILURE, ENSURE SAFETY AND PROPER OPERATION THE TENSIONER ASSEMBLY MUST BE MOUNTED ON THE STUD BEFORE BLEEDING THE SYSTEM AND TENSIONING BEGINS.**

The tensioner has four ports, one for pressurizing, two for bleeding the system and a fourth pressure relief port. To facilitate bleeding, start by first mounting the tensioner at the 9 o'clock stud position. Also, make sure that the pump is always situated below the tensioner assembly.

The tensioner is equipped with 5/8" hex coned stem bleeder fittings installed in the bleeder ports. With these two fittings loosened simultaneously, stroke the pump repeatedly until the streams of oil exiting the tool from each port are free of air, then retighten the fittings.

**Note:** The hose is stiff; use of this tooling can be simplified by temporarily mounting the tensioner on one stud prior to final tightening of fittings. This will reduce the tendency for the fittings to loosen during use.

**9.0 Stud Tensioning**

The studs will be tensioned in two steps, at 50% pressure and at final pressure. Follow the tensioning sequence for each flange joint as defined on the data sheets found at the end of this manual

**WARNING**

**The safety cage MUST be in place and hands kept out of designated areas at all times when the tensioner is pressurized otherwise personal injury can occur.**

**9.1 Tensioning at 50% pressure**

After the tensioner is properly installed apply hydraulic pressure to the tool. Bring the pressure to the 50% level in accordance with the following table.

<u>Flange Position</u>	<u>Stud Size</u>	<u>50% Pressure</u>	<u>50% Stretch</u>
Turbine to Coupling	2-3/4" [71 mm]	10000 psi [690 bar]	Do not measure Do not use
Coupling to Generator	2-3/4" [71 mm]	8000 psi [550 bar]	Do not measure Do not use



215 Clinton Road  
 New Hartford, NY 13413  
 Tel: +1 315 768 4855  
 Fax: +1 315 768 4941  
 Email: info@riverhawk.com

**CUSTOMER'S INFORMATION BOX**  
 CONTENTS ARE INDEPENDENT OF RIVERHAWK DOCUMENT CONTROL

GE DRAWING NUMBER	REV
373A4004	

Turn the cylindrical nut using the spanner ring and pin wrench until it bottoms on the flange.

### 9.2 Removing the Tensioner from an Installed Stud

The tensioner removal is accomplished by the follows steps:

1. Release the hydraulic pressure by either releasing the hand switch on the AP-0532 Pump Kit or by opening the valve on the MP-0130 Manual Pump Kit and leave the valve open.
2. Unscrew the puller screw using a wrench and breaker bar. Do not use an impact wrench as this can damage the tensioner.
3. Move the tool to the next stud/nut assembly to be tensioned, following the sequence/pattern as defined on the supplied data sheets .

### 9.3 Tensioning at Final Pressure

Repeat the pulling and tightening procedure stated above at full pressure.

Turn the cylindrical nut using the spanner ring and pin wrench until it bottoms on the flange.

Measure the length of the each stud after all of the studs have been fully tensioned. The final pressure and required stretch values are listed in the following table:

<u>Flange Position</u>	<u>Stud Size</u>	<u>Final Pressure</u>	<u>Final Stretch</u>
Turbine to Coupling	2-3/4" [71 mm]	17000 psi [1170 bar]	0.022" - 0.024" [0.56 mm - 0.61 mm]
Coupling to Generator	2-3/4" [71 mm]	16000 psi [1100 bar]	0.011" - 0.013" [0.28 mm - 0.33 mm]

**Note:** Before threading the puller screw into the stud, carefully check the cleanliness of both the stud's and the puller screw's conical threads. Be sure to remove all dirt from the root of the studs' conical threads. Apply a light coat of clean turbine oil or spray lubricant to the puller screw. Do not use "Never Seize" on the conical threads. This procedure will ease assembly and assure positive mating of the threads before tightening. **DO NOT BACK OFF THE PULLER SCREW.**



215 Clinton Road  
 New Hartford, NY 13413  
 Tel: +1 315 768 4855  
 Fax: +1 315 768 4941  
 Email: info@riverhawk.com

**CUSTOMER'S INFORMATION BOX**  
 CONTENTS ARE INDEPENDENT OF RIVERHAWK DOCUMENT CONTROL

GE DRAWING NUMBER	REV
373A4004	

**CAUTION**

DO NOT EXCEED THE MAXIMUM PRESSURE VIBROSCRIBED ON THE PULLER BODY. Excessive pressure can damage the stud and puller screw.

Have the final stretch values approved by the supervisor responsible for the installation.

**10.0 Thread Locking**

Once pulling and tensioning is completed all stud nuts must be locked in position. Mechanical Locknuts have two set screws located in the top face (see Figure 4).



Figure 4 – Mechanical Locknut

Once the nut has been seated with the spanner ring and pin wrench, torque the set screws to the values specified in the following table.

When seated and torqued to the values specified the load created by the set screw moves the nut's thread to create the locking action.



215 Clinton Road  
New Hartford, NY 13413  
Tel: +1 315 768 4855  
Fax: +1 315 768 4941  
Email: info@riverhawk.com

**CUSTOMER'S INFORMATION BOX**  
CONTENTS ARE INDEPENDENT OF RIVERHAWK DOCUMENT CONTROL

GE DRAWING NUMBER	REV
373A4004	

Revision C  
Page 22 of 35

<u>Stud Size</u>	<u>Set Screw Size</u>	<u>Torque</u>
2-1/4" [58 mm]	1/4"-28 UN	70 in·lbs - 80 in·lbs [7.9 N·m - 9.0 N·m]
2-3/4" [71 mm]	3/8"-24 UN	200 in·lbs - 250 in·lbs [22.6 N·m - 28.2 N·m]

### 11.0 Windage Plug Installation

#### 11.1 Turbine Side Windage Plugs

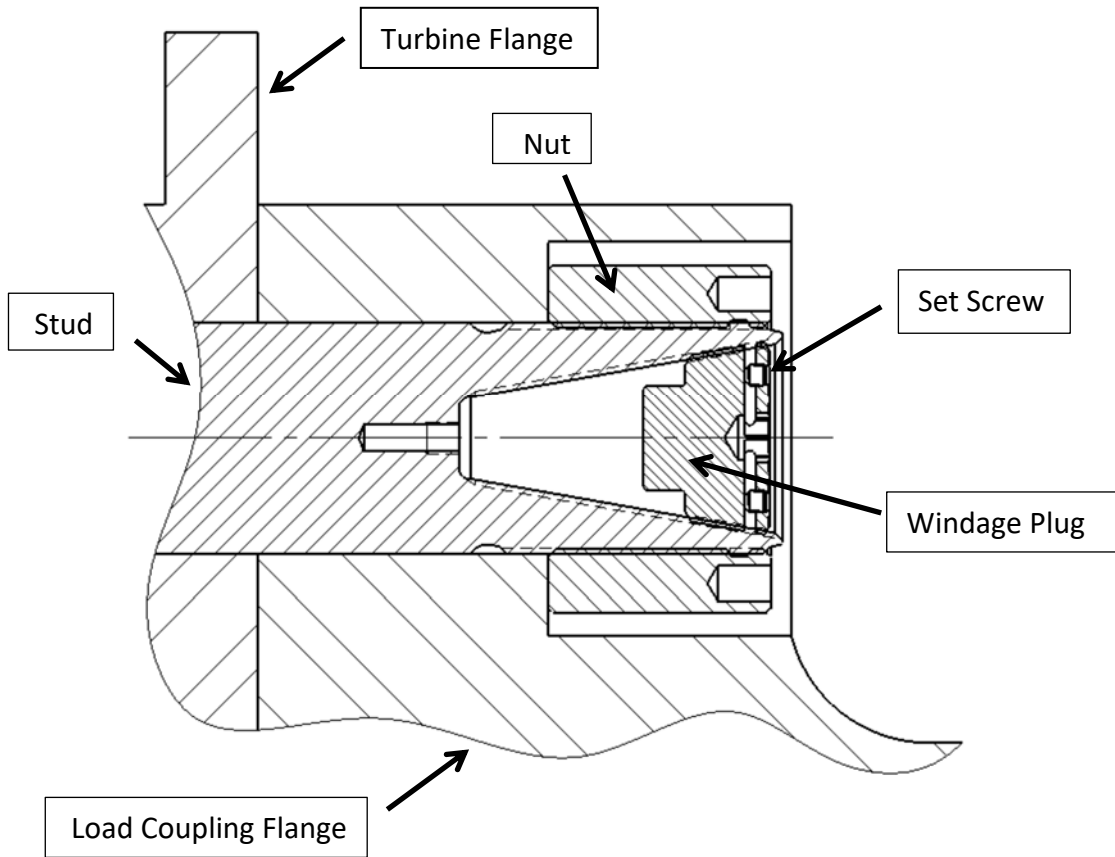

1. Using a 1/2" [12.7 mm] Allen wrench, thread windage plug fully into the stud's conical thread.



215 Clinton Road  
 New Hartford, NY 13413  
 Tel: +1 315 768 4855  
 Fax: +1 315 768 4941  
 Email: info@riverhawk.com

**CUSTOMER'S INFORMATION BOX**  
 CONTENTS ARE INDEPENDENT OF RIVERHAWK DOCUMENT CONTROL

GE DRAWING NUMBER	REV
373A4004	

2. Torque the plug to 200-250 in-lbs [22.6-28.2 N-m].
3. Torque the plug's two set screws.

Windage Plug Part Number	Set Screw Torque
7001867	80-90 in-lbs [9.0-10.1 N-m].
7003513	145-155 in-lbs [16.4-17.5 N-m].

**CAUTION**

The windage plugs must rest a minimum of .06" [1.5 mm] below the end of the stud

**11.2 Generator Side Windage Plugs**

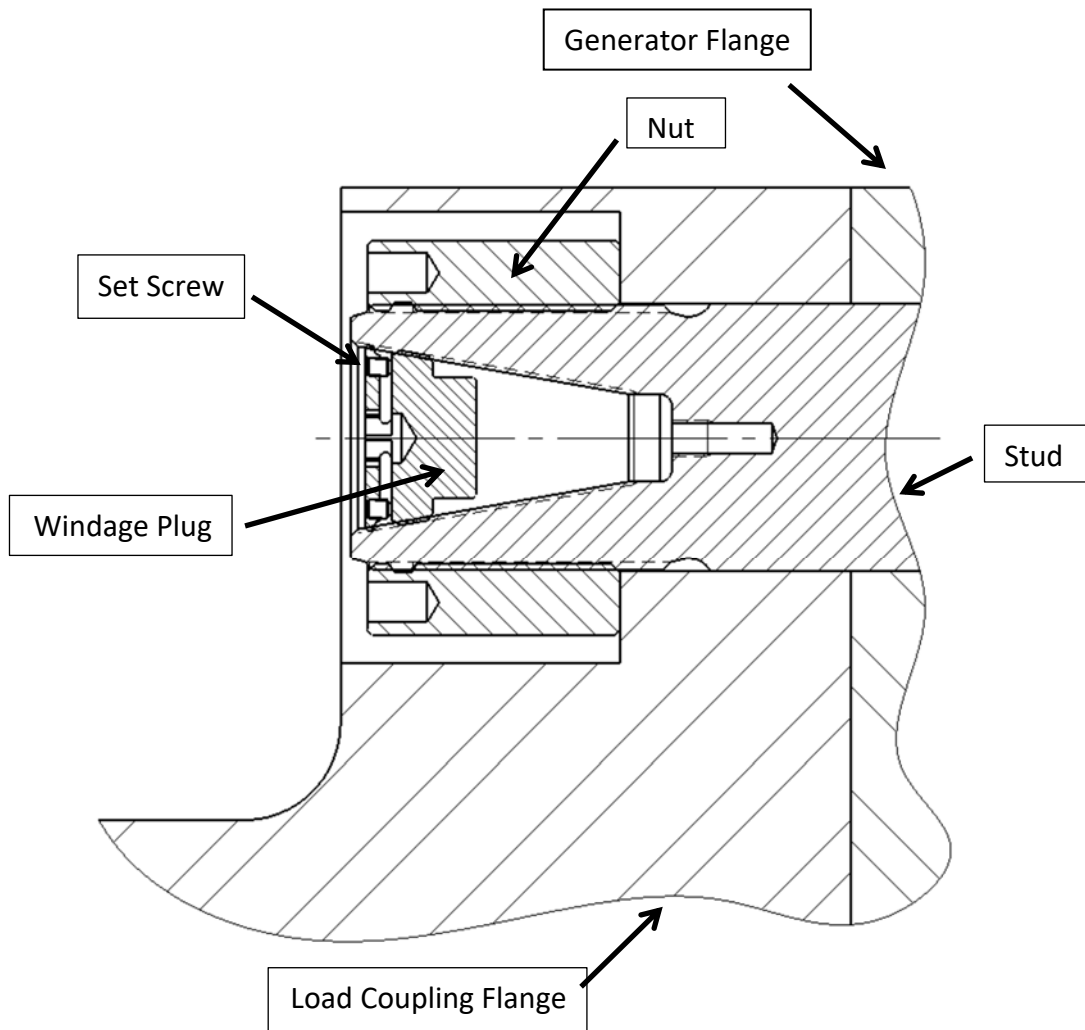

**CUSTOMER'S INFORMATION BOX**  
 CONTENTS ARE INDEPENDENT OF RIVERHAWK DOCUMENT CONTROL

GE DRAWING NUMBER	REV
373A4004	



215 Clinton Road  
 New Hartford, NY 13413  
 Tel: +1 315 768 4855  
 Fax: +1 315 768 4941  
 Email: info@riverhawk.com



1. Using a 1/2" [12.7 mm] Allen wrench, thread windage plug fully into the stud's conical thread.
2. Torque the plug to 200-250 in-lbs [22.6-28.2 N-m].
3. Torque the plug's set screws.

Windage Plug Part Number	Set Screw Torque
7001867	80-90 in-lbs [9.0-10.1 N-m].
7003513	145-155 in-lbs [16.4-17.5 N-m].

**CAUTION**

The windage plugs must rest a minimum of .06" [1.5 mm] below the end of the stud

**12.0 Stud and Nut Removal**

Begin by checking the stick-out dimension of the installed studs. The installed stick-out dimension should be less than the un-installed stick out dimension (see drawings in Section 2.0) plus twice the stretch value from Section 9.3. If the stick-dimensions are high, contact Riverhawk for the special instructions.

**12.1 Removal of Windage Plugs**

1. Remove any dirt on or around the windage plug in the stud.
2. Torque the two set screws to release the mechanical locking feature.
3. Using a 1/2" Allen wrench, torque the windage plug to remove it from the stud

See section 11.0 for diagrams.

**12.2 Removal of Assemblies with Mechanical Locknuts**

1. Using a wire brush, GT-4253, and shop air clean the internal tapered thread of the stud to remove any debris/deposits which may have accumulated during service as described in section 5.2.2.



215 Clinton Road  
 New Hartford, NY 13413  
 Tel: +1 315 768 4855  
 Fax: +1 315 768 4941  
 Email: info@riverhawk.com

**CUSTOMER'S INFORMATION BOX**  
 CONTENTS ARE INDEPENDENT OF RIVERHAWK DOCUMENT CONTROL

GE DRAWING NUMBER	REV
373A4004	

2. With an Allen-wrench, loosen the two locking set screws but do not remove from the nut.

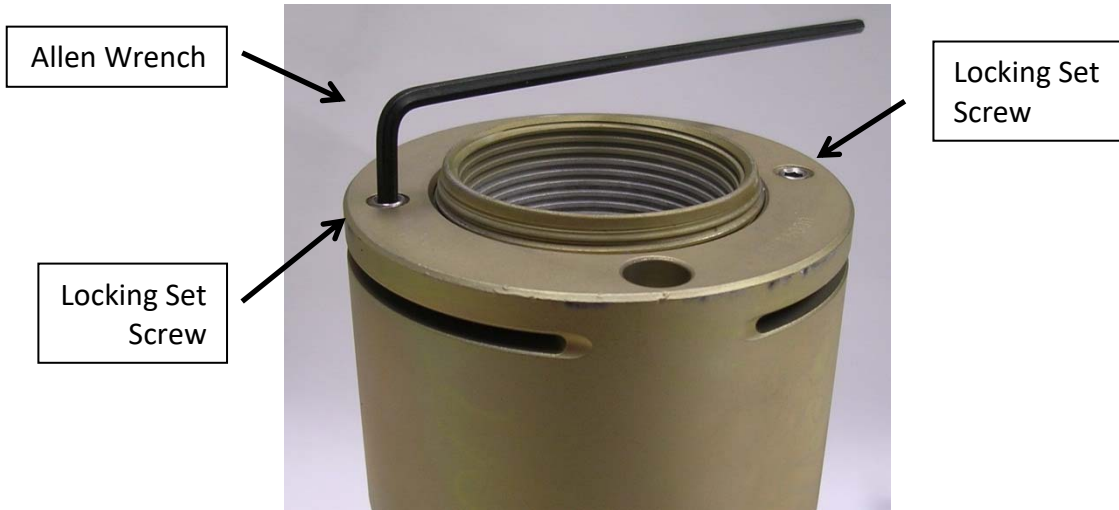

Sample Picture of the loosening of a nut's set screws

3. Install the appropriate tensioner to the stud as described in Section 8.0.
4. Apply the appropriate hydraulic pressure. **REMEMBER: DO NOT BACK OFF THE PULLER SCREW.**

<u>Flange Position</u>	<u>Stud Size</u>	<u>Removal Pressure</u>
Turbine to Coupling	2-3/4" [71 mm]	17500 psi [1210 bar]
Coupling to Generator	2-3/4" [71 mm]	16500 psi [1140 bar]

5. Using the spanner ring and pin wrench, loosen the nut, then release the pressure.

### 12.3 Removing the Tensioner from a Stud

The tensioner removal is to accomplished by the follows steps:



215 Clinton Road  
New Hartford, NY 13413  
Tel: +1 315 768 4855  
Fax: +1 315 768 4941  
Email: info@riverhawk.com

CUSTOMER'S INFORMATION BOX  
CONTENTS ARE INDEPENDENT OF RIVERHAWK DOCUMENT CONTROL

GE DRAWING NUMBER	REV
373A4004	

1. Release the hydraulic pressure by either releasing the hand switch on the AP-0532 Pump Kit or by opening the valve on the MP-0130 Manual Pump Kit and leave the valve open.
2. Insert 1/2" hex Allen wrench into the back side of the stud to prevent the stud from rotating while you unscrew the puller screw.
3. Unscrew the puller screw using a wrench and, if necessary, a breaker bar. Do not use an impact wrench as this can damage the tensioner.
4. Move the tool to the next stud/nut assembly to be tensioned, following the sequence/pattern as defined on the supplied data sheets.

### 13.0 Storage Instructions

Follow these directions to properly store your hydraulic tensioner and hydraulic pump kit for long term storage and shipment.

If any damage is observed, contact the Riverhawk Company to schedule a maintenance inspection.

#### 13.1 Hydraulic Pump Kit Storage

##### 13.1.1 AP-0532 Air-Driven hydraulic pump

Plug the pump's hydraulic port with the pump's metal plug.

The red oil reservoir cap should be removed and stored inside the pump with the extra air hose fittings.

Place the grey and black storage cap into the oil reservoir opening and tighten to secure the oil from spillage.

Check the hydraulic hose for any damage including bent hose ends and split outer lining. If any damaged is found, replace the hose immediately by contacting the Riverhawk Company.

Place red plastic end caps on the hose ends to protect the hose ends from damage.



215 Clinton Road  
New Hartford, NY 13413  
Tel: +1 315 768 4855  
Fax: +1 315 768 4941  
Email: info@riverhawk.com

**CUSTOMER'S INFORMATION BOX**  
CONTENTS ARE INDEPENDENT OF RIVERHAWK DOCUMENT CONTROL

GE DRAWING NUMBER	REV
373A4004	

Revision C  
Page 27 of 35

Wind the hydraulic hose into a circle no smaller than 14" (360mm) and place into the original shipping container.

Place the hydraulic pump kit into the original shipping container.

### 13.1.2 MP-0130 Manual hydraulic pump

Plug the pump's hydraulic port with the pump's metal plug  
Secure the grey vent plug on the reservoir with a 3/8" (10mm) hex Allen key.

Check the hydraulic hose for any damage including bent hose ends and split outer lining. If any damaged is found, replace the hose immediately by contacting the Riverhawk Company.

Place red plastic end caps on the hose ends to protect the hose ends from damage.

Wind the hydraulic hose around the pump and secure in place with the hose clamps.

Place the hydraulic pump kit into the original shipping container.

### 13.2 Hydraulic Tensioner Storage

Check the tensioner for any damage

1. Clean puller screw and check for any debris and dents.
2. Puller screw should be free to rotate and move back and forth.
3. Seam between cylinders closed tightly.
4. Inspect tensioner guard for any signs of damage. Bent guards should be replaced. Also, be sure the rubber pad is in place on the end of the guard, if missing, replace.

If any damage is observed, contact the Riverhawk Company to schedule a maintenance inspection.

Place protective red plastic cap into the hydraulic port.

Coat the hydraulic tensioner with a light coat of oil and place the tensioner into the original shipping container.



215 Clinton Road  
New Hartford, NY 13413  
Tel: +1 315 768 4855  
Fax: +1 315 768 4941  
Email: info@riverhawk.com

**CUSTOMER'S INFORMATION BOX**  
CONTENTS ARE INDEPENDENT OF RIVERHAWK DOCUMENT CONTROL

GE DRAWING NUMBER	REV
373A4004	

### 13.3 Store shipping container

Secure the hydraulic pump and hydraulic tensioner into the original shipping containers using the supplied wood braces.

Seal the original shipping container and store under shelter and protected from moisture, sand, and grit.

### 14.0 Frequently Asked Questions

This section contains some frequently asked questions and problems. If the steps listed here do not solve your problem, contact the Riverhawk Company thru our website, email, or phone call.

- Q:** A tensioner has pulled itself out of the stud's conical threads. Can I continue using a tensioner on this stud?
- A:** No. Both the tensioner and the stud may have been damaged. If the stud is tensioned, a Nut Buster repair kit, from Riverhawk, must be used to remove the damaged stud by drilling out the nut. Riverhawk can supply a replacement stud and nut based on the initial weight certification supplied with the hardware set (see section 4.2). The damaged tensioner should also be returned to Riverhawk for inspection and repair.
- Q:** The hydraulic tensioner has been taken up to its final pressure. The final stretch length is short of the final stretch target. What is the next step?
- A:** Do not increase the hydraulic pressure. Check if the hydraulic pump is set to the right pressure. Install the tensioner and re-pressurize the tensioner to the final pressure then recheck the stretch measurement. If the stretch value is still short, remove the stud from the hole and re-measure the stud's initial length then try to install the stud again.
- Q:** The hydraulic tensioner has been taken up to its final pressure. The final stretch length is larger than the final stretch target. What is the next step?
- A:** Remove the stud from the bolt hole. Check if the hydraulic pump is set to the right pressure. Re-measure the stud's initial length then try to install the stud again.



215 Clinton Road  
New Hartford, NY 13413  
Tel: +1 315 768 4855  
Fax: +1 315 768 4941  
Email: info@riverhawk.com

**CUSTOMER'S INFORMATION BOX**  
CONTENTS ARE INDEPENDENT OF RIVERHAWK DOCUMENT CONTROL

GE DRAWING NUMBER	REV
373A4004	

- Q:** Is there an easier way to support or move the tensioner around the coupling shaft?
- A:** Use two straps. One around the coupling shaft and the other attach to any overhead support. Straps must be slack during mounting tensioner to stud and during tensioning.
- Q:** The tensioner is at its final pressure, but the nut cannot be loosen.
- A:** If the nuts cannot be loosened at the final pressure, continually increasing the pressure will not help and can be dangerous and in some cases make it harder to remove the nut. Check the nut to see if its set screws have been loosened. Check for and remove any corrosion around the nut's threads.
- Q:** How do I clean the conical threads on a stud?
- A:** The conical threads are best cleaned using a spiral wound brass brush in a drill as described in section 5.2.1
- Q:** During the initial steps of removing a tensioned stud, the stick-out length is found to be wrong.
- A:** Do not proceed. Contact Riverhawk for assistance. With the wrong stick-out length, the hydraulic tensioner has a limited stroke and may not work properly and can be damaged.
- Q:** The hydraulic pump appears to be leaking.
- A:** Check the hose connection to the hydraulic pump. If the 1/4" high pressure fitting is not assembled correctly it may look like the pump is leaking. If the problem continues, it may be necessary to open the pump kit. Contact Riverhawk for guidance.
- Q:** The hydraulic hose has a collar on it that can't be moved by hand
- A:** The collar is sometimes held in place with a thread locking compound. This prevents the collar from moving too easily. It may be necessary to adjust this collar with a set of vise-grip pliers. Be careful to not strip the threads off the tube or hose end.



215 Clinton Road  
New Hartford, NY 13413  
Tel: +1 315 768 4855  
Fax: +1 315 768 4941  
Email: info@riverhawk.com

**CUSTOMER'S INFORMATION BOX**  
CONTENTS ARE INDEPENDENT OF RIVERHAWK DOCUMENT CONTROL

GE DRAWING NUMBER	REV
373A4004	

**15.0 Revision History**

Revision Letter	Effective Date	Description
C	Feb 1, 2023	Added Windage Plug Part Number chart to section 11.1 and 11.2
B	May 3, 2022	Updated EC Declaration of Conformity; Added UKCA Declaration of Conformity
A	Jan 2, 2013	Added EC Statement (Appendix A3)
-	Feb 14, 2012	Released



215 Clinton Road  
 New Hartford, NY 13413  
 Tel: +1 315 768 4855  
 Fax: +1 315 768 4941  
 Email: info@riverhawk.com

**CUSTOMER'S INFORMATION BOX**  
 CONTENTS ARE INDEPENDENT OF RIVERHAWK DOCUMENT CONTROL

GE DRAWING NUMBER	REV
373A4004	

## Appendix A1

### EC Declaration of Conformity

Manufacturer: Riverhawk Company  
Address: 215 Clinton Road  
New Hartford, NY 13413, USA

The hydraulic pump and bolt tensioning tool described in this manual are used for installing and applying tension to large bolts that are specifically designed by Riverhawk Company to be tensioned hydraulically.

All applicable sections of European Directive 2006/42/EC for machinery have been applied and fulfilled in the design and manufacture of the hydraulic pump and bolt tensioning tool described in this manual. Reference also ISO 12100:2010, ISO 4413:2010, and ISO 4414:2010.

Furthermore, this equipment has been manufactured under the Riverhawk quality system per EN ISO 9001:2015

Consult the Declaration of Conformance included with the shipment of this equipment that identifies the authorized Riverhawk representative, applicable serial numbers, and appropriate signature.



215 Clinton Road  
New Hartford, NY 13413  
Tel: +1 315 768 4855  
Fax: +1 315 768 4941  
Email: info@riverhawk.com

**CUSTOMER'S INFORMATION BOX**  
CONTENTS ARE INDEPENDENT OF RIVERHAWK DOCUMENT CONTROL

GE DRAWING NUMBER	REV
373A4004	

Revision C  
Page 32 of 35



## Appendix A2

### UKCA Declaration of Conformity

Manufacturer: Riverhawk Company  
Address: 215 Clinton Road  
New Hartford, NY 13413, USA

The hydraulic pump and bolt tensioning tool described in this manual are used for installing and applying tension to large bolts that are specifically designed by Riverhawk Company to be tensioned hydraulically.

All applicable sections of Supply of Machinery (Safety) 2008 have been applied and fulfilled in the design and manufacture of the hydraulic pump and bolt tensioning tool described in this manual. Reference also ISO 12100:2010, ISO 4413:2010, and ISO 4414:2010.

Furthermore, this equipment has been manufactured under the Riverhawk quality system per EN ISO 9001:2015

Consult the Declaration of Conformance included with the shipment of this equipment that identifies the authorized Riverhawk representative, applicable serial numbers, and appropriate signature.



215 Clinton Road  
New Hartford, NY 13413  
Tel: +1 315 768 4855  
Fax: +1 315 768 4941  
Email: info@riverhawk.com

**CUSTOMER'S INFORMATION BOX**  
CONTENTS ARE INDEPENDENT OF RIVERHAWK DOCUMENT CONTROL

GE DRAWING NUMBER	REV
373A4004	

Revision C  
Page 33 of 35

**Appendix B1**

STRETCH RECORD SHEET FOR THE TURBINE END

TURBINE NUMBER:

DATE:

TECHNICIAN:

SUPERVISOR:

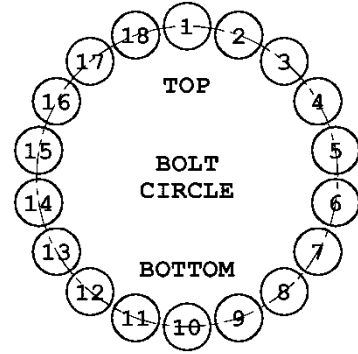

HOLE NUMBER	STARTING LENGTH	FINAL LENGTH	FINAL STRETCH
1			
10			
2			
11			
3			
12			
4			
13			
5			
14			
6			
15			
7			
16			
8			
17			
9			
18			

**CUSTOMER'S INFORMATION BOX**  
 CONTENTS ARE INDEPENDENT OF RIVERHAWK DOCUMENT CONTROL

GE DRAWING NUMBER	REV
373A4004	



215 Clinton Road  
 New Hartford, NY 13413  
 Tel: +1 315 768 4855  
 Fax: +1 315 768 4941  
 Email: info@riverhawk.com

**Appendix B2**

STRETCH RECORD SHEET FOR THE GENERATOR END

TURBINE NUMBER:

DATE:

TECHNICIAN:

SUPERVISOR:

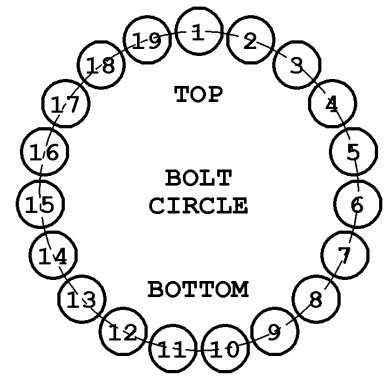

HOLE NUMBER	STARTING LENGTH	FINAL LENGTH	FINAL STRETCH
1			
11			
6			
16			
2			
12			
7			
17			
3			
13			
8			
18			
4			
14			
9			
19			
5			
15			
10			

**CUSTOMER'S INFORMATION BOX**  
 CONTENTS ARE INDEPENDENT OF RIVERHAWK DOCUMENT CONTROL

GE DRAWING NUMBER	REV
373A4004	



215 Clinton Road  
 New Hartford, NY 13413  
 Tel: +1 315 768 4855  
 Fax: +1 315 768 4941  
 Email: info@riverhawk.com