



INSTRUCTION MANUAL IM-152
For Gas Turbine and Steam Turbine
Tensioned Studs and Nuts

Applicable Bolting Connections

Fr. 9FB or Fr. 9FA Gas Turbine to 330H or 450H Generator
 Fr. 9FB or Fr. 9FA to Load Coupling
 Load Coupling or Steam Turbine to 330H or 450H Generator
 Fr. 9FB or Fr. 9FA Gas Turbine to 330H or 450H Generator with Windage Plugs
 Steam Turbine to 330H or 450H Generator
 Fr. 9FA to Load Coupling

Applicable GE Ordering Sheet Part Numbers

382A4341P001	403A4659G001	HPEC-JJ-382A4341G004
382A4341P002		HPEC-JJ-382A4341P005
382A4341P003	808L7424G0001	
382A4341P004		HE-BSII-361A6162P003
382A4341P005		HE-BSII-361A6162P005
382A4341P006		
382A4341P007		

CUSTOMER'S INFORMATION BOX

CONTENTS ARE INDEPENDENT OF RIVERHAWK DOCUMENT CONTROL

GE Power & Water		GENERAL ELECTRIC COMPANY	
<u>VENDOR SUPPLIED</u>			
GE NOT TO REVISE. GE REVISION LEVEL IS SHOWN ON THIS APPLIQUE. THIS DOCUMENT IS FILED UNDER THE GE DRAWING NUMBER.			
THIS DOCUMENT SHALL BE REVISED IN ITS ENTIRETY. ALL SHEETS OF THIS DOCUMENT ARE THE SAME REVISION LEVEL AS INDICATED IN THIS VENDOR SUPPLIED DRAWING APPLIQUE.			
MLI: _____ OF _____			
GE SIGNATURES		DATE	
CHECKED:		GE DRAWING NUMBER	
ISSUED:		373A4009	
_____		REV	

The Riverhawk Company reserves the right to update this document without dissemination or notice. The latest revision may be obtained by contacting Riverhawk Company or thru www.riverhawk.com.



Repairs – Rentals
 Field Service

215 Clinton Road
 New Hartford, NY 13413
 Tel: +1 315 768 4855
 Fax: +1 315 768 4941
 Email: info@riverhawk.com

Table of Contents

Section	Description	Page Number
1.0	Cautions and Safety Warnings	3
2.0	Scope and GE Part Number Cross Reference	5
3.0	Quick Checklist	7
4.0	General Preparations	9
5.0	Hardware Set Preparations	11
6.0	Stud and Nut Assembly	14
7.0	Hydraulic Tensioner Equipment Assembly	16
8.0	Assembly of Tensioner on Stud	18
9.0	Stud Tensioning	21
10.0	Thread Locking and Windage Plug Installation	23
11.0	Stud and Nut Removal	25
12.0	Storage Instructions	27
13.0	Frequently Asked Questions	28
14.0	Revision History	30
Appendix A1	EC Declaration of Conformity	32
Appendix A2	UKCA Declaration of Conformity	33
Appendix B1	Hydraulic Fittings	34
Appendix B2	Puller Screw Release Tape	35
Appendix C1	18-Bolt Tensioning Pattern (GT-LC) Record Sheet	36
Appendix C2	18-Bolt Tensioning Pattern (LC-LG) Record Sheet	37



215 Clinton Road
 New Hartford, NY 13413
 Tel: +1 315 768 4855
 Fax: +1 315 768 4941
 Email: info@riverhawk.com

CUSTOMER'S INFORMATION BOX
 CONTENTS ARE INDEPENDENT OF RIVERHAWK DOCUMENT CONTROL

GE DRAWING NUMBER	REV
373A4009	

1.0 Cautions and Safety Warnings

WARNING

Improper tool use and the failure to follow the correct procedures are the primary root causes of tool failures and personal injuries. A lack of training or experience can lead to incorrect hardware installation or incorrect tool use. Only trained operators with careful, deliberate actions should use hydraulic tensioners. Contact Riverhawk Company with any training needs.

WARNING

Risk of high pressure hydraulic fluid injection. Riverhawk tools operate under high pressure. Thoroughly inspect all hoses and connections for damage or leaks prior to using this equipment.

CAUTION

Personal injury and equipment damage can occur if the proper health and safety codes and procedures are not followed. Contact the site's health and safety office to determine all applicable safety rules and regulations.

WARNING

The proper personal protective equipment must be worn at all times. Riverhawk recommends at a minimum, safety glasses, long sleeve shirt, hard hat, heavy work gloves, and steel toe shoes.

CAUTION

It is especially important to check the condition of the conical thread used to tension the stud. Thread damage from previous abuse can lead to failure of the stud or tensioning equipment

CAUTION

Riverhawk recommends that the tensioner should be returned to Riverhawk for periodic inspections. Replacement of obsolete tensioners is recommended. Functional upgrades are also recommended. The Riverhawk Service Returns Coordinator should be notified 3-6 months prior to a planned outage to schedule an inspection service.

WARNING

A damaged burst disc must be replaced with a with a burst disc of the same design and pressure rating. Do not substitute a damaged burst disc with a different disc type, a different pressure rating, or a foreign object.



215 Clinton Road
New Hartford, NY 13413
Tel: +1 315 768 4855
Fax: +1 315 768 4941
Email: info@riverhawk.com

CUSTOMER'S INFORMATION BOX
CONTENTS ARE INDEPENDENT OF RIVERHAWK DOCUMENT CONTROL

GE DRAWING NUMBER	REV
373A4009	

Revision R
Page 3 of 37

WARNING

To avoid failure, ensure safety, and proper operation, the tensioner assembly must be installed on a stud in the flange before bleeding and pressurizing the tensioner. Do not use the tensioner at any pressure unless the tool is installed on a stud in a flange.

CAUTION

Do not over extend the tensioner. Over extension can cause the piston to lose its seal and leak oil.

CAUTION

Personal injury and equipment damage can occur if the puller screw is not securely engaged with the tapered threads of the stud. Proper engagement is achieved when the puller screw is tight in the stud and the tensioner assembly is free to turn.

WARNING

The safety cage must be in place at all times. When the tensioner is pressurized hands must be kept out of designated areas to avoid any potential for personal injury.

CAUTION

Before threading the puller screw into the stud, carefully check the cleanliness of both the stud's and the puller screw's conical threads. Apply a light coat of clean turbine oil or a spray lubricant to the puller screw. This procedure will ease assembly and assure positive mating of the threads before tightening. Do not use "Never Seize" on the conical threads.

CAUTION

Do not tighten the nut while the tool is coming up to pressure; wait until pressure is achieved before attempting to tighten the nut with the spanner ring. If the tool is not properly installed, the tool could jump off the stud while coming up to pressure.

CAUTION

Do not exceed the maximum pressure marked on the tensioner. Excessive pressure can damage the stud and puller screw.

WARNING

FIRE HAZARD: DO NOT heat when puller assembly is in place. Personal injury or equipment damage may occur. Use of an Oxy-Acetylene torch is not recommended



215 Clinton Road
New Hartford, NY 13413
Tel: +1 315 768 4855
Fax: +1 315 768 4941
Email: info@riverhawk.com

CUSTOMER'S INFORMATION BOX
CONTENTS ARE INDEPENDENT OF RIVERHAWK DOCUMENT CONTROL

GE DRAWING NUMBER	REV
373A4009	

2.0 Scope

This document describes the procedure to be used to install the stud and nut sets supplied by the Riverhawk Company in the flanges at the Turbine/Coupling, Coupling/Generator, and Steam Turbine/Generator connections.

The various frame configurations covered in this manual are listed in Sections 2.1 through 2.7 with differences as related to connective hardware defined. Listed also are the pertinent hardware drawings (HF-xxxx). These drawings as well as tooling drawings (HT-xxxx) form part of this manual.

2.1 Frame 9FB or Frame 9FA Gas Turbine to 330H or 450H Generator

GE PART NUMBER	RIVERHAWK P/N	GE VENDOC P/N
GE 382A4341P001	HF-2019	GE 359B2518
GE 382A4341P002	HF-2019	GE 359B2518

The hydraulic tool used for installation and removal is Riverhawk HT-2287.

These hardware drawings depict the complete stud and nut package for the Gas Turbine to Load Coupling (3" size, Qty 18) as well as the Load Coupling to Generator (3" size, Qty 18).

2.2 Frame 9FB or Frame 9FA Gas Turbine to Load Coupling

GE PART NUMBER	RIVERHAWK P/N	GE VENDOC P/N
GE 382A4341P004	HF-2523	GE 359B2541

The hydraulic tool used for installation and removal is Riverhawk HT-2287.

These hardware drawings depict the complete stud and nut package for the Gas Turbine to Load Coupling (3" size, Qty 18).

2.3 Load Coupling or Steam Turbine to 330H or 450H Generator

GE PART NUMBER	RIVERHAWK P/N	GE VENDOC P/N
GE 382A4341P003	HF-2523	GE 359B2541

The hydraulic tool used for installation and removal is Riverhawk HT-2287.

These hardware drawings depict the complete stud and nut package for the Load Coupling or Steam Turbine to Generator (3" size, Qty 18).



215 Clinton Road
 New Hartford, NY 13413
 Tel: +1 315 768 4855
 Fax: +1 315 768 4941
 Email: info@riverhawk.com

CUSTOMER'S INFORMATION BOX
 CONTENTS ARE INDEPENDENT OF RIVERHAWK DOCUMENT CONTROL

GE DRAWING NUMBER	REV
373A4009	

2.4 Frame 9FB or Frame 9FA Gas Turbine to 330H or 450H Generator with Windage Plugs

GE PART NUMBER	RIVERHAWK P/N	GE VENDOC P/N
GE 382A4341P005	HF-3447	GE 359B2585
GE 382A4341P006	HF-3447	GE 359B2585

The hydraulic tool used for installation and removal is Riverhawk HT-2287.

These hardware drawings depict the complete stud and nut package for the Gas Turbine to Load Coupling (3" size, Qty 18) as well as the Load Coupling to Generator (3" size, Qty 18). The drawings also depict the windage plugs (Qty 36) used to enclose the conical thread of each stud.

2.5 Steam Turbine to 330H or 450H Generator

GE PART NUMBER	RIVERHAWK P/N	GE VENDOC P/N
GE 808L7424G0001	HF-2523 MTP-4779	GE 359B2541 GE 368B4792

The hydraulic tool used for installation and removal is Riverhawk HT-2287.

These hardware drawings depict the complete stud and nut package for the Gas Turbine to Load Coupling (3" size, Qty 18) as well as the Load Coupling to Generator (3" size, Qty 18). The drawings also depict the alignment pins (Qty 2) used to align the flange prior to bolting.

2.6 Frame 9FA to Load Coupling

GE HARBIN PART NUMBER	RIVERHAWK P/N
HPEC-JJ-382A4341G004	HF-3794
HPEC-JJ-382A4341P005	HF-3794
HE-BSII-361A6162P003	HF-5379
HE-BSII-361A6162P005	HF-5379

The hydraulic tool used for installation and removal is Riverhawk HT-3795.

These hardware drawings depict the complete stud and nut package for the Gas Turbine to Load Coupling (3" size, Qty 18). The drawing HF-5379 also depicts the windage plugs (Qty 18) used to enclose the conical thread of each stud.



215 Clinton Road
 New Hartford, NY 13413
 Tel: +1 315 768 4855
 Fax: +1 315 768 4941
 Email: info@riverhawk.com

CUSTOMER'S INFORMATION BOX
 CONTENTS ARE INDEPENDENT OF RIVERHAWK DOCUMENT CONTROL

GE DRAWING NUMBER	REV
373A4009	

2.7 Hydraulic Tooling

GE PART NUMBER	RIVERHAWK P/N	GE VENDOC P/N
GE 382A4341P007	HT-2287	GE 359B2538
	AP-0532	GE 359B2502
GE 403A4659G001	HT-2287	GE 359B2538

3.0 Quick Checklist

The following checklist is intended as a summary of the steps needed to use the Riverhawk-supplied equipment. New personnel or those experienced personnel who have not used the Riverhawk equipment recently are encouraged to read the entire manual.

EQUIPMENT INSPECTION

- Check oil level in hydraulic pump.
- Check air pressure at 80psi [5.5 bar] minimum. (For air-driven pumps)
- Check hydraulic hose for damage.
- Test pump.
- Inspect tensioner for any damage.

NUT AND STUD PREPARATION

- Inspect studs and nuts for any damage.
- Clean the studs and nuts.
- Measure stud lengths. (VERY IMPORTANT)
- Install studs and nuts (off-center) into the flange.
- Set stick-out dimension on the coupling side of the flange.



215 Clinton Road
 New Hartford, NY 13413
 Tel: +1 315 768 4855
 Fax: +1 315 768 4941
 Email: info@riverhawk.com

CUSTOMER'S INFORMATION BOX
 CONTENTS ARE INDEPENDENT OF RIVERHAWK DOCUMENT CONTROL

GE DRAWING NUMBER	REV
373A4009	

- Hand tighten nuts on turbine / generator side of flange.
- Verify stick-out measurement (**VERY IMPORTANT**)

TENSIONING (Bolt Installation)

- Check tensioner drawing for correct parts and part numbers.
- Apply a light coat of clean turbine oil or spray lubricant to the puller screw. **DO NOT USE “NEVER SEIZE” ON THE CONICAL THREADS.**
- Install one puller screw release tape strip into stud. (Appendix B2)
- Slide spanner ring over the puller screw.
- Install the tensioner on the stud in flange and slide spanner ring onto nut.
- Insert 1/2” hex Allen wrench into the back side of the stud.
- Tighten the puller screw. Then back off puller screw 1/2 a turn.
- Retighten the puller screw and leave tight. **DO NOT BACK OFF PULLER SCREW.**
- Bleed the tensioner. **Do NOT bleed tensioner off of a stud! Damage to the tool will result!**
- Tension to 50%. Consult manual for correct pressure.
- Use the pin wrench in spanner ring to tighten nut.
- Release pressure, move to next stud in pattern.
- Repeat above steps at final pressure.
- Measure final stud length and record on stretch datasheets. Calculate stretch.
- Torque the nuts' set screws.



215 Clinton Road
New Hartford, NY 13413
Tel: +1 315 768 4855
Fax: +1 315 768 4941
Email: info@riverhawk.com

CUSTOMER'S INFORMATION BOX
CONTENTS ARE INDEPENDENT OF RIVERHAWK DOCUMENT CONTROL

GE DRAWING NUMBER	REV
373A4009	

- Install the windage plugs and torque their set screws (if required).

DETENSIONING (Stud Removal)

- If installed, loosen the windage plugs' set screws and remove the windage plugs from the studs
- Loosen nuts' set screws
- Inspect and clean studs' conical threads. **Do not continue until ALL debris is removed from the threads!** See instruction manual IM-220. **Do not try to use the tensioner to remove a damaged stud!**
- Apply a light coat of clean turbine oil or spray lubricant to the puller screw. **DO NOT USE "NEVER SEIZE" ON THE CONICAL THREADS.**
- Slide spanner ring over the puller screw.
- Install the tensioner on the stud.
- Install spanner ring into nut.
- Tighten the puller screw. Then back off puller screw 1/2 a turn.
- Retighten the puller screw and leave tight. **DO NOT BACK OFF PULLER SCREW.**
- Bleed the tensioner. **Do NOT bleed tensioner off of a stud! Damage to the tool will result!**
- Apply final pressure.
- Loosen nut with the spanner ring and pin wrench.
- Move to next stud in pattern

4.0 General Preparations

Read and understand all instructions before installing and tensioning studs.



215 Clinton Road
New Hartford, NY 13413
Tel: +1 315 768 4855
Fax: +1 315 768 4941
Email: info@riverhawk.com

CUSTOMER'S INFORMATION BOX
CONTENTS ARE INDEPENDENT OF RIVERHAWK DOCUMENT CONTROL

GE DRAWING NUMBER	REV
373A4009	

Operators should be trained or have previous experience using Riverhawk tensioning equipment. Training will minimize the chance of improper use of the equipment.

The hydraulic tooling including the hydraulic hoses should be inspected prior to use. Inspection guidelines are listed in the following sub-sections.

This equipment produces very high hydraulic pressures and very high forces. Operators must exercise caution and wear the appropriate personal protective equipment when handling and operating the hydraulic tooling.

High-pressure oil from the hydraulic pump pressurizes the tensioner which generates a very large force that actually stretches the stud. As the stud is stretched the nut lifts off the flange. The nut is then turned by hand using the supplied spanner ring. Once the nut is tight against the flange, the pressure in the tensioner is released. The hardware is now clamping the flange together.

4.1 Machine Preparation

The flange to be tensioned must be fully closed prior to positioning of studs in the flanges. Turning the turbine and generator shafts is not required, but may be useful. Also, it will be advantageous to remove as many obstructions as possible from the flange area, such as speed probes, shipping plates, and conduit.

4.2 Hardware – Balance

Hardware is supplied as weight balanced sets. Studs and Nuts are interchangeable within sets. Do not intermix sets.

Save the weight certification supplied with each set. It will be needed for the purchase of replacement hardware.

4.3 Tensioner – Care and Handling

When not in use, the tensioner shall be maintained in a clean environment and all caps and plugs for hydraulic openings and fittings must be in place.

Use ISO 32 grade oil.

When in use, the tensioner shall be protected from sand and grit.

See section 12 for long term storage requirements.



215 Clinton Road
New Hartford, NY 13413
Tel: +1 315 768 4855
Fax: +1 315 768 4941
Email: info@riverhawk.com

CUSTOMER'S INFORMATION BOX
CONTENTS ARE INDEPENDENT OF RIVERHAWK DOCUMENT CONTROL

GE DRAWING NUMBER	REV
373A4009	

4.4 Hand Tools

Several hand wrenches and micrometers will be required to perform installation and measurement of the studs:

5/8" Wrench	1" Socket Wrench	3' to 4' Breaker Bar
1" Wrench	A set of Allen Wrenches	12" to 13" Micrometer

4.5 Special Tools

Hydraulic Tensioner Kit:	HT-2287 Hydraulic Tensioner, 3" (reference GE VENDOC 3592538)
	HT-3795 Hydraulic Tensioner, 3"

Hydraulic Pump Kit:	AP-0532 Air-Operated Hydraulic Pump (recommended) (reference GE VENDOC 359B2502)
	MP-0130 Manual Hand-Operated Hydraulic Pump (reference GE VENDOC 359B2506)

CAUTION

Riverhawk recommends that the tensioners be returned to Riverhawk for periodic inspections. Replacement of obsolete tensioners is recommended. Functional upgrades are also recommended. The Riverhawk Service Returns Coordinator should be notified 3-6 months prior to a planned outage to schedule an inspection service.

5.0 Hardware Set Preparations



215 Clinton Road
New Hartford, NY 13413
Tel: +1 315 768 4855
Fax: +1 315 768 4941
Email: info@riverhawk.com

CUSTOMER'S INFORMATION BOX
CONTENTS ARE INDEPENDENT OF RIVERHAWK DOCUMENT CONTROL

GE DRAWING NUMBER	REV
373A4009	

Revision R
Page 11 of 37

5.1 Nut Preparation

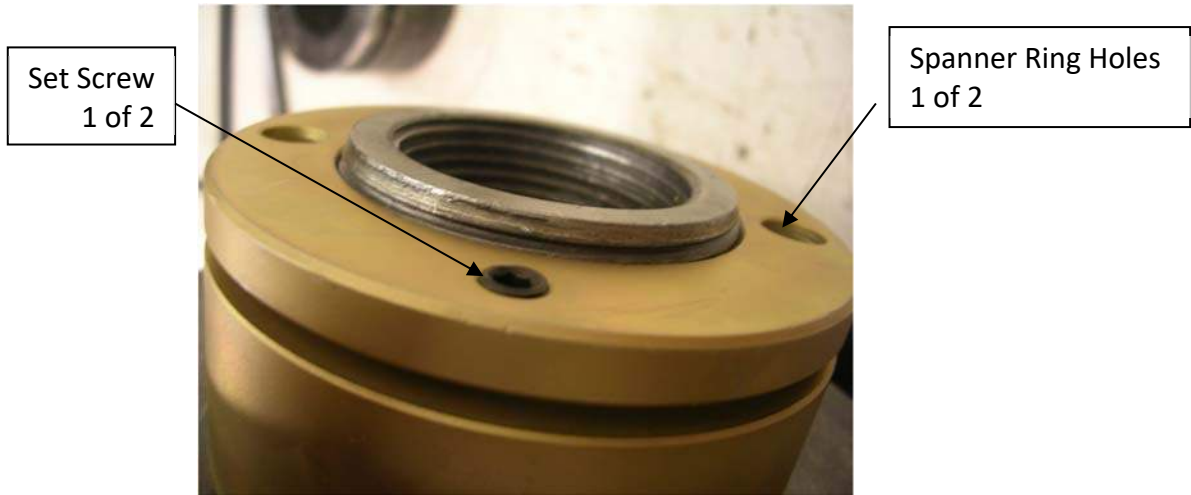

Picture 1 - Riverhawk Locknut

If there is any visible damage on a nut, do not use the nut and contact the Riverhawk Company for a replacement nut. Please be prepared to supply the turbine number, weight certification, and digital photographs for evaluation.

5.1.1 Nut Cleaning - New Installations

For new installations, the nuts should come sealed from the factory and will need no cleaning.

5.1.2 Nut Cleaning - Old Installations

Previously installed nuts require cleaning as follows: Wire brush using a petroleum-based solvent to remove any foreign material on the external surfaces and threads.

5.2 Stud Preparation

Check the stud for any visible damage. If there is any visible damage, do not use the stud and contact the Riverhawk Company for a replacement stud. Please be prepared to supply the turbine number, weight certification, and digital photographs for evaluation.



215 Clinton Road
New Hartford, NY 13413
Tel: +1 315 768 4855
Fax: +1 315 768 4941
Email: info@riverhawk.com

CUSTOMER'S INFORMATION BOX
CONTENTS ARE INDEPENDENT OF RIVERHAWK DOCUMENT CONTROL

GE DRAWING NUMBER	REV
373A4009	

Revision R
Page 12 of 37

CAUTION

It is especially important to check the condition of the conical thread used to tension the stud. Thread damage from previous abuse can lead to failure of the stud or tensioning equipment.

The conical threads of each stud must be clean of grit and dirt before installation or removal. This ensures the proper seating of the puller screw.

5.2.1 Stud Cleaning - New Installations

For new installations, the studs should come sealed from the factory and will need no cleaning.

5.2.2 Stud Cleaning - Old Installations

Previously installed studs may require cleaning. Clean conical threads should have a bright and shiny appearance.

If cleaning is required, follow these steps:

1. Blow out the threads with compressed air to remove loose debris and dry conical threads. Do not apply a solvent or other cleaning solution to the threads as this may chemically attack the stud.
2. Use Stud Cleaning Kit, GT-4253 or a similar 1" diameter Brass power brush.



Picture 2 - Brass Power Brush

3. Insert the brush into an electric drill and set drill to run in a counterclockwise direction at high speed.
4. Work the drill in a circular motion while moving the brush in and out to clean all of the threads. Try not to hold the brush in one place too long, so as not to remove the stud's protective coating.
5. Blow out the threads with compressed air to remove loosened debris.
6. Visually inspect threads for cleanliness. Threads should be bright and shiny.
7. Repeat if any dirt can be seen in the threads.



215 Clinton Road
New Hartford, NY 13413
Tel: +1 315 768 4855
Fax: +1 315 768 4941
Email: info@riverhawk.com

CUSTOMER'S INFORMATION BOX
CONTENTS ARE INDEPENDENT OF RIVERHAWK DOCUMENT CONTROL

GE DRAWING NUMBER	REV
373A4009	

8. Inspect threads for any damage that may have been caused by previous installation.
9. Do **not** apply thread lubricants such as “Never Seize” to the stud’s threads.
10. Finish the cleaning process by rinsing in a volatile solvent such as acetone and allow to dry.

5.3 Stud Length Measurement

Measure and record the initial lengths of the studs. The following suggestions will improve your results.

- **Plan to start and finish any flange in the same day.**
- **Studs and flange must be at the same temperature.**
- **Number each stud with a marker for later stretch measurement tracking.**
- **Mark the location of measurement on stud end with a permanent marker.**
- **Measure each stud to nearest 0.001 inch (.01 mm).**
- **Record each measurement on the supplied record sheets.**
- **Do not allow the measuring instruments to sit in the sun.**
- **The same person should make all measurements.**

6.0 Stud and Nut Assembly

Refer to the hardware assembly drawing (HF-xxxx) listed in Section 2.0 of this manual.

1. Assemble the cylindrical nut to the internal, conical thread end of the stud.
2. Slide the stud and cylindrical nut assembly into the flange as shown in Figure 1.



215 Clinton Road
New Hartford, NY 13413
Tel: +1 315 768 4855
Fax: +1 315 768 4941
Email: info@riverhawk.com

CUSTOMER'S INFORMATION BOX
CONTENTS ARE INDEPENDENT OF RIVERHAWK DOCUMENT CONTROL

GE DRAWING NUMBER	REV
373A4009	

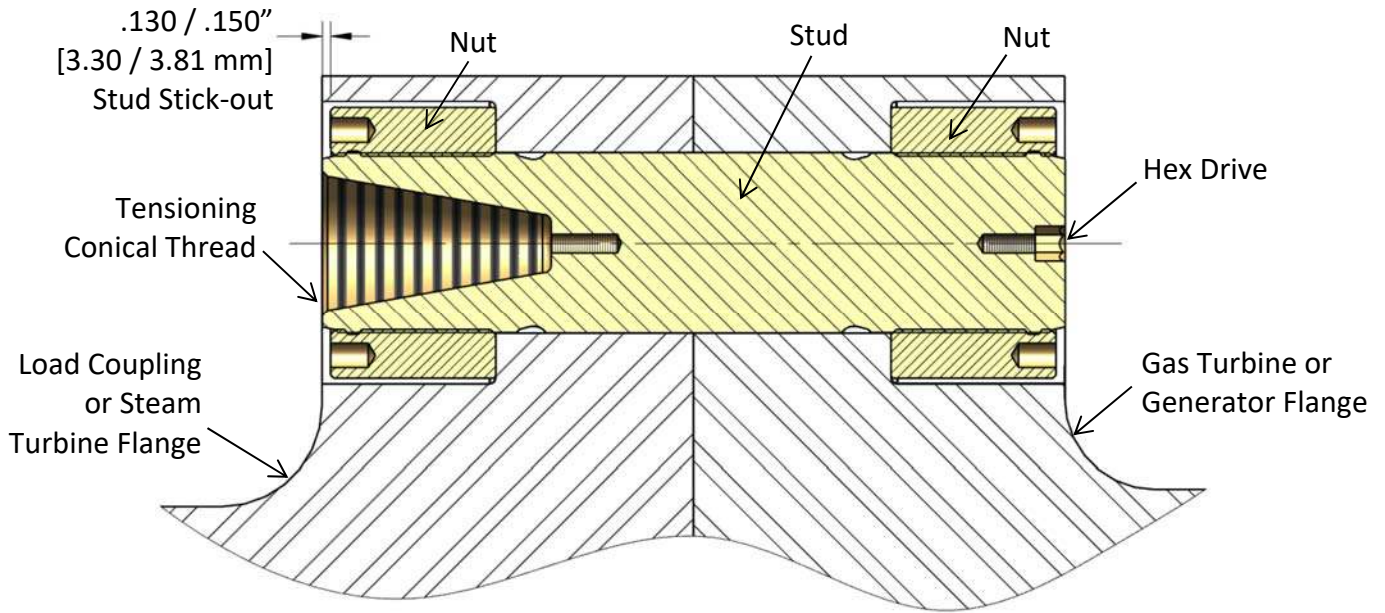

Figure 1 – Cross-section View of Bolted Flange Connection

3. Install the other nut on the backside.
4. Adjust the nut/stud assembly so that the stud sticks out (protrudes) from the face of the nut the amount shown. Best practice is to verify the stud stick-out dimension with the hardware set drawing for your application. If you don't have the hardware set drawing, it can be found in the GE Vendocs system or contact Riverhawk Company. (See section 2)

SETTING THIS PROTRUSION OF STUD TO NUT IS CRITICAL FOR PROPER TENSIONER OPERATION. A metal stick-out gage is provided with the tensioner to assist the operator in setting the protrusion dimension



215 Clinton Road
 New Hartford, NY 13413
 Tel: +1 315 768 4855
 Fax: +1 315 768 4941
 Email: info@riverhawk.com

CUSTOMER'S INFORMATION BOX
 CONTENTS ARE INDEPENDENT OF RIVERHAWK DOCUMENT CONTROL

GE DRAWING NUMBER	REV
373A4009	



Picture 3 – Use of Stick-Out Gage

5. Hand tighten the assembly to a snug fit.
6. Recheck the stud stick-out length. If the stick-out length does not match the hardware drawing, adjust the nuts as necessary.

7.0 Hydraulic Tensioner Equipment Assembly

7.1 Hydraulic Equipment Inspection

7.1.1 Hydraulic Tensioner Inspection

CAUTION

Riverhawk recommends that the tensioner be returned to Riverhawk for periodic inspections. Replacement of obsolete tensioners is recommended. Functional upgrades are also recommended. The Riverhawk Service Returns Coordinator should be notified 3-6 months prior to a planned outage to schedule an inspection service.

Do **not** bleed the air from the hydraulic lines and tensioner at this time. See section 8 for bleeding instructions on when to bleed the air from the hydraulic lines.

WARNING

To avoid failure, ensure safety, and proper operation, the tensioner assembly must be installed on a stud in the flange before bleeding and pressurizing the tensioner. Do not use the tensioner at any pressure unless the tool is installed on a stud in a flange.

Check puller screw usage life with Riverhawk service bulletin SB-08001.



215 Clinton Road
New Hartford, NY 13413
Tel: +1 315 768 4855
Fax: +1 315 768 4941
Email: info@riverhawk.com

CUSTOMER'S INFORMATION BOX
CONTENTS ARE INDEPENDENT OF RIVERHAWK DOCUMENT CONTROL

GE DRAWING NUMBER	REV
373A4009	

Revision R
Page 16 of 37

Clean puller screw and check for any debris and dents.

Puller screw should be free to rotate and move back and forth.

Seam between cylinders closed tightly.

Inspect the tensioner guard for any signs of damage including cracked welds. Any guards modified in the field should be replaced. Bent guards should be replaced. Also, be sure the rubber pad is in place on the end of the guard, if missing, replace.

Inspect the outside of the tensioner for discoloration patterns that may indicate submersion and internal damage.

Perform an inventory of the loose equipment supplied with the tensioner. An inventory list is provided on the tensioner's technical drawing (for example Riverhawk HT-xxxx). Replacement parts are available from Riverhawk.

7.1.1.1 Hydraulic Tensioner's Burst Disc Replacement

The hydraulic tensioner's burst disc is a key element in the overall safe use of the hydraulic tensioner.

Each tensioner is shipped from our factory with one burst disc already installed in the tensioner and with another spare disc for field replacement. Extra burst discs are available from Riverhawk for replacement purposes.

To replace a damaged burst disc:

1. Remove the hydraulic port's dispersion nut, compression ring, and damaged burst disc.
2. Discard the damaged burst disc.
3. Clean the dispersion nut, compression ring, new burst disc, and the hydraulic port with a solvent to ensure a dirt-free installation.
4. Reassemble new burst disc, compression ring, and dispersion nut into the same hydraulic port.

Warning

A damaged burst disc must be replaced with a with a burst disc of the same design and pressure rating. Do not substitute a damaged burst disc with a different disc type, a different pressure rating, or a foreign object.



215 Clinton Road
New Hartford, NY 13413
Tel: +1 315 768 4855
Fax: +1 315 768 4941
Email: info@riverhawk.com

CUSTOMER'S INFORMATION BOX
CONTENTS ARE INDEPENDENT OF RIVERHAWK DOCUMENT CONTROL

GE DRAWING NUMBER	REV
373A4009	

7.1.2 Hydraulic Pump Kit Inspection

Refer to the Hydraulic Pump Kit Instruction Manual, IM-293 (GE VENDOC 373A4058). The latest revision may be obtained by contacting Riverhawk Company or thru www.riverhawk.com.

7.1.3 Hydraulic Hose Inspection

Check the hydraulic hose for any damage including bent hose ends and split outer lining. If any damaged is found, replace the hose immediately by contacting the Riverhawk Company.

7.2 Hydraulic Fittings

Information on the correct assembly of the hydraulic pump's and hydraulic hose's hydraulic fittings can be found in Appendix B1.

8.0 Assembly of Tensioner on a Stud

8.1 Handling of the Tensioner

Rest the tensioner on top of the coupling shaft. Using a strap just long enough to go around the coupling shaft, attach each end to the handles of the tensioner. One way to do this is to attach the strap by looping the strap through itself around the handle of the tensioner on one side then around the coupling shaft and finally attached to the handle on the other side with a D-shackle. This will help hold the tensioner in place should it fall off of the shaft. The strap also helps the operators move the tensioner around the shaft while tensioning.

If possible, use a 'Come-along' or chain fall from the ceiling of the coupling room and attach it to the tensioner using a short strap wrapped through the handles and around the top of the tensioner. This will allow the operators to easily move the tensioner around the coupling shaft by supporting the weight of the tool.

8.2 Kit Assembly

Assemble the hydraulic pump with its hose to the tensioner and bleed out the air per following instructions in section 8.3.

Refer to the hardware assembly drawing (HF-xxxx) listed in Section 2.0 of this manual and the tensioner assembly drawing (HT-xxxx) listed in Section 4.5 of this manual to determine which side of the flange the tensioner must be located on in order to use the tensioner properly.



215 Clinton Road
New Hartford, NY 13413
Tel: +1 315 768 4855
Fax: +1 315 768 4941
Email: info@riverhawk.com

CUSTOMER'S INFORMATION BOX
CONTENTS ARE INDEPENDENT OF RIVERHAWK DOCUMENT CONTROL

GE DRAWING NUMBER	REV
373A4009	

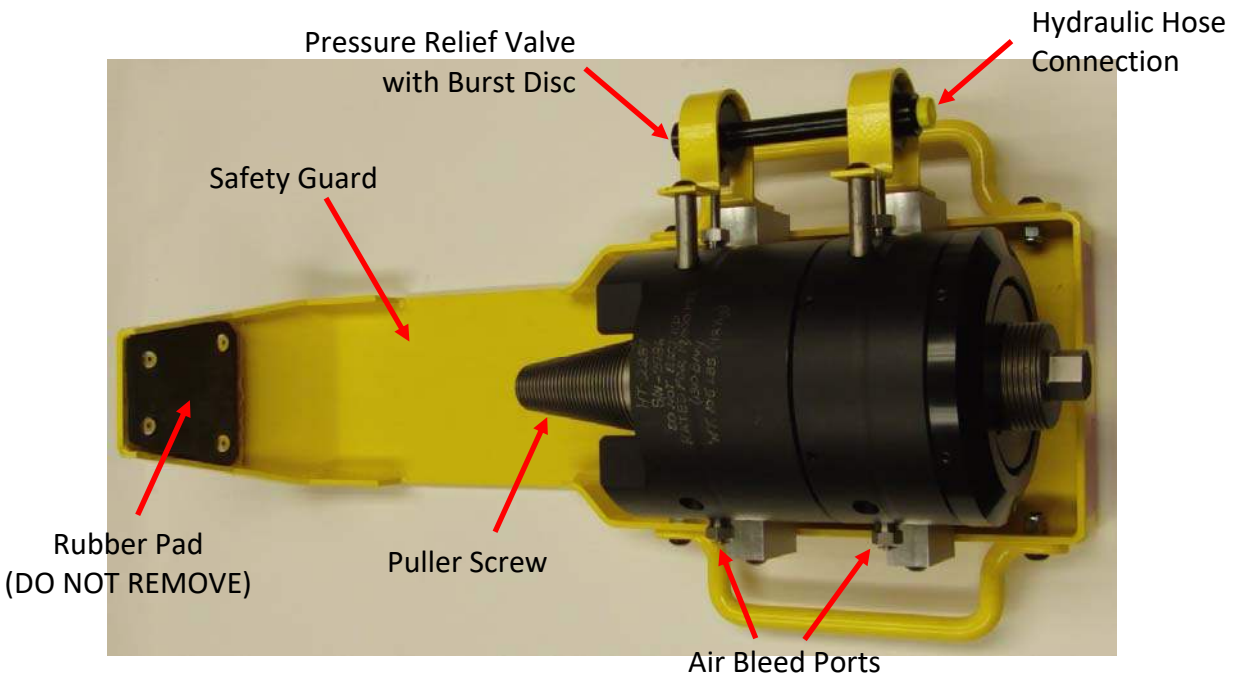

Picture 4 – Features of the Hydraulic Tensioner

Note: Before threading the puller screw into the stud, carefully check the cleanliness of both the stud's and the puller screw's conical threads. Apply a light coat of clean turbine oil or a spray lubricant to the puller screw. Do not use "Never Seize" on the conical threads. This procedure will ease assembly and assure positive mating of the threads before tightening.

Assembly sequence is as follows:

1. Open the hydraulic return valve on the pump to allow hydraulic fluid to be pushed back from the puller tool into the pump reservoir. (This is automatic on the air-operated hydraulic pump)
2. Place the spanner ring over the puller screw on the tensioner.
3. Install one puller screw release tape strip into the end of the stud. (Appendix B2)
4. Apply a light coat of clean turbine oil or a spray lubricant to the puller screw. Do not use "Never Seize" on the conical threads.
5. Place and hold the tensioner assembly over the end of the stud to be tightened.
6. Slide the puller screw in to the tapered thread of the stud and hand tighten. **Be sure not to cross thread assembly.**
7. Hold the stud steady with a 1/2" hex key wrench and lightly tighten the puller screw into the conical thread of the stud with a wrench.



215 Clinton Road
 New Hartford, NY 13413
 Tel: +1 315 768 4855
 Fax: +1 315 768 4941
 Email: info@riverhawk.com

CUSTOMER'S INFORMATION BOX
 CONTENTS ARE INDEPENDENT OF RIVERHAWK DOCUMENT CONTROL

GE DRAWING NUMBER	REV
373A4009	

8. Place the spanner ring on the cylindrical nut located on the stud.
9. At this point the Tensioner Assembly **MUST BE FREE TO ROTATE**, the puller screw must be tight in the stud. **DO NOT BACK OFF PULLER SCREW.**

If the tensioner is not free to rotate when the puller screw is tight then, either (1) the stud is not properly positioned in the flange and recheck the stick-out length and reposition the nuts, or (2) The tensioner is damaged and must be returned for repair.

CAUTION

Do not over extend the stud. Over extension can cause the piston to lose its seal and leak oil.

CAUTION

Personal injury and equipment damage can occur if the puller screw is not securely engaged with the tapered threads of the stud. Proper engagement is achieved when the puller screw is tight in the stud and the tensioner assembly is free to turn.

8.3 Bleeding Hydraulic System

WARNING

To avoid failure, ensure safety, and proper operation, the tensioner assembly must be installed on a stud in the flange before bleeding and pressurizing the tensioner. Do not use the tensioner at any pressure unless the tool is installed on a stud in a flange.

The tensioner has four ports, one for pressurizing, two for bleeding the system, and a fourth pressure relief port. To facilitate bleeding, start by first mounting the tensioner at the 9 o'clock stud position, this will critically place the bleed ports in their uppermost position. In addition, make sure that the pump is always situated below the tensioner assembly.

The tensioner is equipped with 5/8" hex coned stem bleeder fittings installed in the bleeder ports. With these two fittings loosened simultaneously, stroke the pump repeatedly until the streams of oil exiting the tool from each port are free of air, then retighten the fittings.

Note: The hose is stiff; use of this tooling can be simplified by temporarily installing the tensioner on one stud prior to final tightening of fittings. This will reduce the tendency for the fittings to loosen during use.



215 Clinton Road
New Hartford, NY 13413
Tel: +1 315 768 4855
Fax: +1 315 768 4941
Email: info@riverhawk.com

CUSTOMER'S INFORMATION BOX
CONTENTS ARE INDEPENDENT OF RIVERHAWK DOCUMENT CONTROL

GE DRAWING NUMBER	REV
373A4009	

9.0 Stud Tensioning

The studs will be tensioned in two steps, at 50% pressure and at final pressure. Follow the tensioning sequence for each flange joint as defined on the record sheets found at the end of this manual.

9.1 Tensioning at 50% pressure

After the tensioner is properly installed apply hydraulic pressure to the tool. Bring the pressure to the 50% level in accordance with the following table.

WARNING

The safety cage must be in place at all times. Keep hands out of designated areas at all times when the tensioner is pressurized otherwise personal injury can occur.

CAUTION

Before threading the puller screw into the stud, carefully check the cleanliness of both the stud's and the puller screw's conical threads. Apply a light coat of clean turbine oil or a spray lubricant to the puller screw. This procedure will ease assembly and assure positive mating of the threads before tightening. Do not use "Never Seize" on the conical threads.

CAUTION

Do not exceed the maximum pressure marked on the tensioner. Excessive pressure can damage the stud and puller screw.

CAUTION

Do not tighten the nut while the tool is coming up to pressure; wait until pressure is achieved before attempting to tighten the nut with the spanner ring. If the tool is not properly installed, the tool could jump off the stud while coming up to pressure.

<u>Flange Position</u>	<u>Stud Size</u>	<u>50% Pressure</u>	<u>50% Stretch</u>
Turbine to Coupling	3" [76 mm]	10000 psi [690 bar]	Do not measure Do not use
Coupling to Generator	3" [76 mm]	10000 psi [690 bar]	Do not measure Do not use
Steam Turbine to Generator	3" [76 mm]	10000 psi [690 bar]	Do not measure Do not use



215 Clinton Road
New Hartford, NY 13413
Tel: +1 315 768 4855
Fax: +1 315 768 4941
Email: info@riverhawk.com

CUSTOMER'S INFORMATION BOX
CONTENTS ARE INDEPENDENT OF RIVERHAWK DOCUMENT CONTROL

GE DRAWING NUMBER	REV
373A4009	

9.1.1 Tightening of 3" nuts

Turn the cylindrical nut using the spanner ring and pin wrench until it bottoms on the flange.

9.2 Removing the Tensioner from an Installed Stud

The tensioner removal is accomplished by the follows steps:

1. Release the hydraulic pressure by either releasing the hand switch on the AP-0532 Pump Kit or by opening the valve on the MP-0130 Manual Pump Kit and leave the valve open.
2. Unscrew the puller screw using a wrench and breaker bar. Do not use an impact wrench as this can damage the tensioner.
3. Move the tool to the next bolt hole following the tensioning pattern from the stretched record sheets at the end of this manual.

9.3 Tensioning at Final Pressure

Repeat the pulling and tightening procedure stated above at full pressure. After all of the studs have been tensioned, measure the final stud length. The final pressure and required stretch values are listed in the following table.

WARNING

The safety cage must be in place at all times. Keep hands out of designated areas at all times when the tensioner is pressurized otherwise personal injury can occur.

CAUTION

Before threading the puller screw into the stud, carefully check the cleanliness of both the stud's and the puller screw's conical threads. Apply a light coat of clean turbine oil or a spray lubricant to the puller screw. This procedure will ease assembly and assure positive mating of the threads before tightening. Do not use "Never Seize" on the conical threads.

CAUTION

Do not exceed the maximum pressure marked on the tensioner. Excessive pressure can damage the stud and puller screw.

CAUTION

Do not tighten the nut while the tool is coming up to pressure; wait until pressure is achieved before attempting to tighten the nut with the spanner ring. If the tool is not properly installed, the tool could jump off the stud while coming up to pressure.



215 Clinton Road
New Hartford, NY 13413
Tel: +1 315 768 4855
Fax: +1 315 768 4941
Email: info@riverhawk.com

CUSTOMER'S INFORMATION BOX
CONTENTS ARE INDEPENDENT OF RIVERHAWK DOCUMENT CONTROL

GE DRAWING NUMBER	REV
373A4009	

<u>Flange Position</u>	<u>Stud Size</u>	<u>Final Pressure</u>	<u>Final Stretch</u>
Turbine to Coupling	3" [76 mm]	18000 psi [1240 bar]	0.020" - 0.022" [0.51 mm - 0.56 mm]
Coupling to Generator	3" [76 mm]	18000 psi [1240 bar]	0.020" - 0.022" [0.51 mm - 0.56 mm]
Steam Turbine to Generator	3" [76 mm]	18000 psi [1240 bar]	0.020" - 0.022" [0.51 mm - 0.56 mm]

Excessive stretch variations or low stretch values can be corrected by uninstalling all or selected studs to the pressure values stated in the above table. Have final stretch values approved by the supervisor responsible for the installation.

9.3.1 Tightening of 3" nuts

Turn the cylindrical nut using the spanner ring and pin wrench until it bottoms on the flange.

10.0 Thread Locking and Windage Plug Installation

10.1 Thread Locking

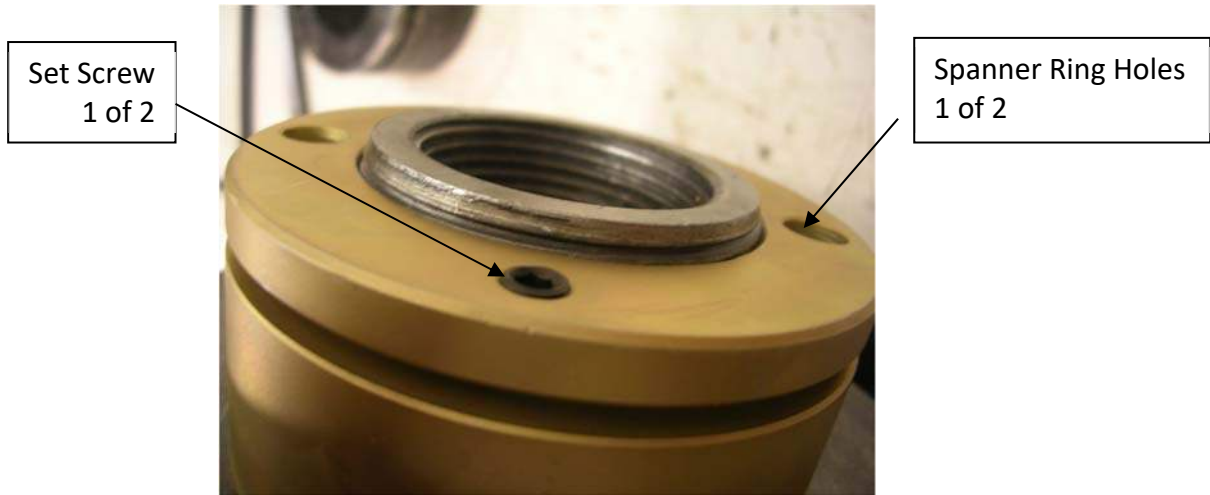

Picture 5 - Riverhawk Locknut

Mechanical lock nuts have two set screws located in the top face. Before threading the nut onto the stud check to be certain the set screws are free to turn. Once the nut is seated torque the set screws to the values specified in the following table. When seated and torqued to the



215 Clinton Road
New Hartford, NY 13413
Tel: +1 315 768 4855
Fax: +1 315 768 4941
Email: info@riverhawk.com

CUSTOMER'S INFORMATION BOX
CONTENTS ARE INDEPENDENT OF RIVERHAWK DOCUMENT CONTROL

GE DRAWING NUMBER	REV
373A4009	

values specified the load created by the set screw displaces the thread of the nut in the area of the web creating the desired locking action.

<u>Stud Size</u>	<u>Set Screw Size</u>	<u>Torque</u>
3" [76 mm]	3/8"-24 UN	200 in·lbs – 250 in·lbs [22.6 N·m – 28.2 N·m]

10.2 Windage Plug Installation

Refer to the hardware assembly drawing (HF-xxxx) listed in Section 2.0 of this manual to determine if windage plugs are required for the installation.

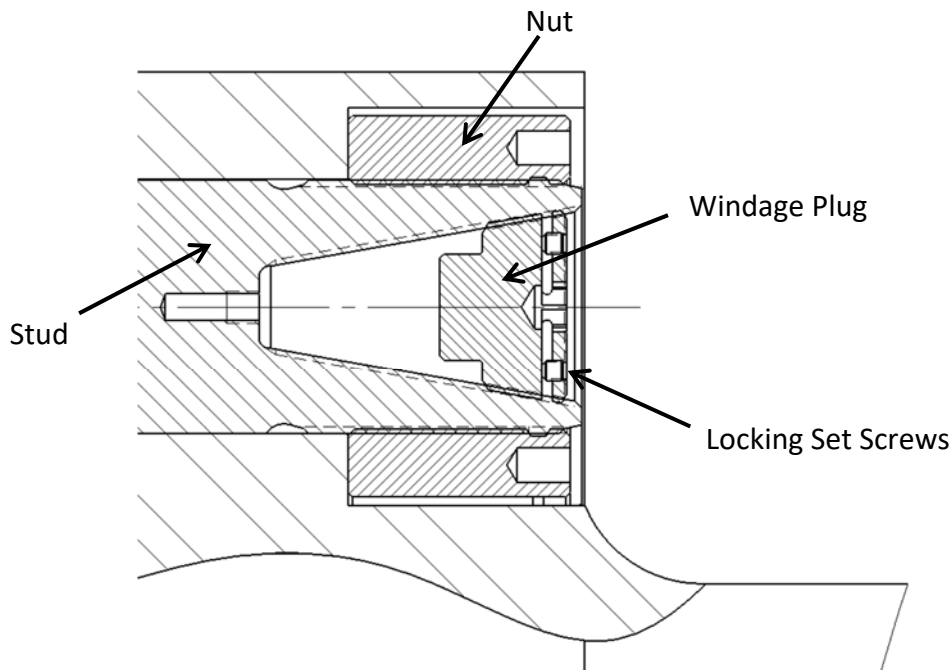

Figure 2 – Windage Plug Installation

Assembly sequence is as follows:

1. Verify the stud's internal threads are clean and free from oil.
2. Fully insert Windage Plug by threading it into the stud's internal thread.
3. Torque the windage plug to 200-250 in·lbs (22.6 – 28.2 N·m).
4. Tighten the windage plug's set screws.



215 Clinton Road
New Hartford, NY 13413
Tel: +1 315 768 4855
Fax: +1 315 768 4941
Email: info@riverhawk.com

CUSTOMER'S INFORMATION BOX
CONTENTS ARE INDEPENDENT OF RIVERHAWK DOCUMENT CONTROL

GE DRAWING NUMBER	REV
373A4009	

Windage Plug Part Number	Set Screw Torque
7001867	80-90 in-lbs [9.0-10.1 N-m].
7003513	145-155 in-lbs [16.4-17.5 N-m].

5. Check the distance the plug is inside of the stud. The plug should be at a minimum of .06" (1.5mm) below the face of the stud.

11.0 Stud and Nut Removal

11.1 Handling of the Tensioner

Rest the tensioner on top of the coupling shaft. Using a strap just long enough to go around the coupling shaft, attach each end to the handles of the tensioner. One way to do this is to attach the strap by looping the strap through itself around the handle of the tensioner on one side then around the coupling shaft and finally attached to the handle on the other side with a D-shackle. This will help hold the tensioner in place should it fall off of the shaft. The strap also helps the operators move the tensioner around the shaft while tensioning.

If possible, use a 'Come-along' or chain fall from the ceiling of the coupling room and attach it to the tensioner using a short strap wrapped through the handles and around the top of the tensioner. This will allow the operators to easily move the tensioner around the coupling shaft by supporting the weight of the tool.

11.2 Stud and Nut Removal

Removal is accomplished as follows:

- If present, remove the windage plugs from the studs by reversing the installation instructions from section 10.2. It may be necessary to use two Allen wrenches: one to stop the windage plug from rotating, one to remove the set screws. Do not misplace the set screws.
- Using a wire brush, GT-4253, and shop air clean the internal tapered thread of the stud to remove any debris/deposits which may have accumulated during service as described in section 5.2.2.
- With an Allen-wrench loosen the two locking set screws but do not remove from the nut.



215 Clinton Road
 New Hartford, NY 13413
 Tel: +1 315 768 4855
 Fax: +1 315 768 4941
 Email: info@riverhawk.com

CUSTOMER'S INFORMATION BOX
 CONTENTS ARE INDEPENDENT OF RIVERHAWK DOCUMENT CONTROL

GE DRAWING NUMBER	REV
373A4009	



Picture 6 - Loosening of a nut's set screws

- Install the appropriate tensioner to the stud as described in Section 8.0.
- Apply the appropriate hydraulic pressure per this table. **DO NOT BACK OFF THE PULLER SCREW.**

<u>Flange Position</u>	<u>Stud Size</u>	<u>Removal Pressure</u>
Turbine to Coupling	3" [76 mm]	18000 psi [1240 bar]
Coupling to Generator	3" [76 mm]	18000 psi [1240 bar]
Steam Turbine to Generator	3" [76 mm]	18000 psi [1240 bar]

- Using the spanner ring and spanner/pin wrenches, loosen the nut, then release the pressure.

11.3.1 Removing the Tensioner from a Stud

The tensioner removal is to accomplished by the follows steps:

1. Release the hydraulic pressure by either releasing the hand switch on the AP-0532 Pump Kit or by opening the valve on the MP-0130 Manual Pump Kit and leave the valve open.
2. Insert 1/2" hex Allen wrench into the back side of the stud to prevent the stud from rotating while you unscrew the puller screw.
3. Unscrew the puller screw using a wrench and, if necessary, a breaker bar. Do not use an impact wrench as this can damage the tensioner.



215 Clinton Road
 New Hartford, NY 13413
 Tel: +1 315 768 4855
 Fax: +1 315 768 4941
 Email: info@riverhawk.com

CUSTOMER'S INFORMATION BOX
 CONTENTS ARE INDEPENDENT OF RIVERHAWK DOCUMENT CONTROL

GE DRAWING NUMBER	REV
373A4009	

4. Move the tool to the next stud/nut assembly to be tensioned, following the sequence/pattern as defined on the supplied data sheets.

12.0 Storage Instructions

Follow these directions to properly store your hydraulic tensioner and hydraulic pump kit for long term storage and shipment.

If any damage is observed, contact the Riverhawk Company to schedule a maintenance inspection.

12.1 Hydraulic Pump Kit Storage

Refer to the Hydraulic Pump Kit Instruction Manual, IM-293 (GE VENDOC 373A4058). The latest revision may be obtained by contacting Riverhawk Company or thru www.riverhawk.com.

12.2 Hydraulic Tensioner Storage

Check the tensioner for any damage

1. Clean puller screw and check for any debris and dents.
2. Puller screw should be free to rotate and move back and forth.
3. Seam between cylinders closed tightly.
4. Inspect tensioner guard for any signs of damage. Bent guards should be replaced. Also, be sure the rubber pad is in place on the end of the guard, if missing, replace.

If any damage is observed, contact the Riverhawk Company to schedule a maintenance inspection.

Place protective red plastic cap into the hydraulic port.

Coat the hydraulic tensioner with a light coat of oil and place the tensioner into the original shipping container.

12.3 Store shipping container

Secure the hydraulic pump and hydraulic tensioner into the original shipping containers using the supplied wood braces.

Seal the original shipping container and store under shelter and protected from moisture, sand, and grit.



215 Clinton Road
New Hartford, NY 13413
Tel: +1 315 768 4855
Fax: +1 315 768 4941
Email: info@riverhawk.com

CUSTOMER'S INFORMATION BOX
CONTENTS ARE INDEPENDENT OF RIVERHAWK DOCUMENT CONTROL

GE DRAWING NUMBER	REV
373A4009	

13.0 Frequently Asked Questions

This section contains some frequently asked questions and problems. If the steps listed here do not solve your problem, contact the Riverhawk Company thru our website, email, or phone call.

Q: Can I rent a hydraulic tensioner kit?

A: Yes, Riverhawk has rental tensioner kits available for most of our hydraulic tensioners.

Q: A tensioner has pulled itself out of the stud's conical threads. Can I continue using a tensioner on this stud?

A: No. Both the tensioner and the stud may have been damaged and must be removed from the work area. If the stud is tensioned, a Nut Buster repair kit, from Riverhawk, must be used to remove the damaged stud by drilling out the nut. Leaving a damaged stud in place will lead to a safety hazard on future outages.

Riverhawk can supply a replacement stud and nut based on the initial weight certification supplied with the hardware set (see section 4.2). The damaged tensioner should also be returned to Riverhawk for inspection and repair.

If a stud must be left in place, paint the damaged stud with a generous amount of indelible, bright-colored paint. Notify the appropriate GE Safety and Service personnel. Note the location of the damaged stud in the services notes for the machine.

Q: The hydraulic tensioner has been taken up to its final pressure. The final stretch length is short of the final stretch target. What is the next step?

A: Do not increase the hydraulic pressure. Check if the hydraulic pump is set to the right pressure. Install the tensioner and re-pressurize the tensioner to the final pressure then recheck the stretch measurement. If the stretch value is still short, remove the stud from the hole and re-measure the stud's initial length then try to install the stud again.



215 Clinton Road
New Hartford, NY 13413
Tel: +1 315 768 4855
Fax: +1 315 768 4941
Email: info@riverhawk.com

CUSTOMER'S INFORMATION BOX
CONTENTS ARE INDEPENDENT OF RIVERHAWK DOCUMENT CONTROL

GE DRAWING NUMBER	REV
373A4009	

Q: The hydraulic tensioner has been taken up to its final pressure. The final stretch length is larger than the final stretch target. What is the next step?

A: Remove the stud from the bolt hole. Check if the hydraulic pump is set to the right pressure. Re-measure the stud's initial length then try to install the stud again.

Q: Is there an easier way to support or move the tensioner around the coupling shaft?

A: In section 8.1, a method using two straps, one around the coupling shaft and the other attach to an overhead support, is described that can help.

Q: The tensioner is at its final pressure, but the nut cannot be loosened.

A: If the nuts cannot be loosened at the final pressure, continually increasing the pressure will not help and can be dangerous and in some cases make it harder to remove the nut. Check the nut to see if its set screws have been loosened. Check for and remove any corrosion around the nut's threads.

Q: How do I clean the conical threads on a stud?

A: The conical threads are best cleaned using a spiral wound brass brush in a drill as described in section 5.2.2

Q: During the initial steps of removing a tensioned stud, the stick-out length is found to be wrong.

A: Do not proceed. Contact Riverhawk for assistance. With the wrong stick-out length, the hydraulic tensioner has a limited stroke and may not work properly and can be damaged.



215 Clinton Road
New Hartford, NY 13413
Tel: +1 315 768 4855
Fax: +1 315 768 4941
Email: info@riverhawk.com

CUSTOMER'S INFORMATION BOX
CONTENTS ARE INDEPENDENT OF RIVERHAWK DOCUMENT CONTROL

GE DRAWING NUMBER	REV
373A4009	

- Q:** The hydraulic pump appears to be leaking.
- A:** Check the hose connection to the hydraulic pump. If the 1/4" high pressure fitting is not assembled correctly as shown in section 7.2, it may look like the pump is leaking. If the problem continues, it may be necessary to open the pump kit. Contact Riverhawk for guidance.
- Q:** The hydraulic hose has a collar on it that can't be moved by hand
- A:** The hydraulic fitting is shown in section 7.2. The collar is sometimes held in place with a thread locking compound. This prevents the collar from moving too easily. It may be necessary to adjust this collar with a set of vise-grip pliers. Be careful to not strip the threads off the tube or hose end.

14.0 Revision History

Revision Letter	Effective Date	Description
R	Feb 1, 2023	Added Windage Plug Part Number chart to section 10.2
P	Jun 30, 2022	Updated figure 1 in section 6; Inserted Appendices B1 and B2
N	May 18, 2022	Updated EC Declaration of Conformity; Added UKCA Declaration of Conformity
M	Jan 15, 2015	Updated section 1.0, 4.3 and Appendix A3.
L	Jun 13, 2014	Updated EC Declaration of Conformity
K	Jan 2, 2013	Added Appendix A3: CE Statement of conformity
J	Nov 9, 2012	Reformatted, general update to warnings and cautions, Added IM-293 to sections 7.1.2 and 12.1, Moved and Renumbered figures and pictures
H	Nov 7, 2011	Added HF-5379 to section 2
G	Sept 12, 2011	Corrected spelling error on figure 1, Revised section 7.1.1, Removed figure 3, Revised stretch record sheets



215 Clinton Road
 New Hartford, NY 13413
 Tel: +1 315 768 4855
 Fax: +1 315 768 4941
 Email: info@riverhawk.com

CUSTOMER'S INFORMATION BOX
 CONTENTS ARE INDEPENDENT OF RIVERHAWK DOCUMENT CONTROL

GE DRAWING NUMBER	REV
373A4009	

Instruction Manual IM-152

F	Nov 29, 2010	Added 9FA Gas Turbine to 330H Generator to title page (page 1), Added 382A4341P005 and 382A4341 P006 to Fr. 9FB to 330H Generator
E	Aug 04, 2010	Added 450H Generator and Steam Turbine to title page (page 1)
D	Jun 10, 2009	Added turbine oil and removed "Never Seize" from sections 1.0, 3.0, 8.0, and 9.0
C	Mar 25, 2009	Added sections 3 and 14
B	Jun 23, 2008	
A	Feb 22, 2007	
-	Jan 09, 2004	Released



215 Clinton Road
 New Hartford, NY 13413
 Tel: +1 315 768 4855
 Fax: +1 315 768 4941
 Email: info@riverhawk.com

CUSTOMER'S INFORMATION BOX
 CONTENTS ARE INDEPENDENT OF RIVERHAWK DOCUMENT CONTROL

GE DRAWING NUMBER	REV
373A4009	

Appendix A1

EC Declaration of Conformity

Manufacturer: Riverhawk Company
Address: 215 Clinton Road
New Hartford, NY 13413, USA

The hydraulic pump and bolt tensioning tool described in this manual are used for installing and applying tension to large bolts that are specifically designed by Riverhawk Company to be tensioned hydraulically.

All applicable sections of European Directive 2006/42/EC for machinery have been applied and fulfilled in the design and manufacture of the hydraulic pump and bolt tensioning tool described in this manual. Reference also ISO 12100:2010, ISO 4413:2010, and ISO 4414:2010.

Furthermore, this equipment has been manufactured under the Riverhawk quality system per EN ISO 9001:2015

Consult the Declaration of Conformance included with the shipment of this equipment that identifies the authorized Riverhawk representative, applicable serial numbers, and appropriate signature.



215 Clinton Road
New Hartford, NY 13413
Tel: +1 315 768 4855
Fax: +1 315 768 4941
Email: info@riverhawk.com

CUSTOMER'S INFORMATION BOX
CONTENTS ARE INDEPENDENT OF RIVERHAWK DOCUMENT CONTROL

GE DRAWING NUMBER	REV
373A4009	

Appendix A2

UKCA Declaration of Conformity

Manufacturer: Riverhawk Company
Address: 215 Clinton Road
New Hartford, NY 13413, USA

The hydraulic pump and bolt tensioning tool described in this manual are used for installing and applying tension to large bolts that are specifically designed by Riverhawk Company to be tensioned hydraulically.

All applicable sections of Supply of Machinery (Safety) 2008 have been applied and fulfilled in the design and manufacture of the hydraulic pump and bolt tensioning tool described in this manual. Reference also ISO 12100:2010, ISO 4413:2010, and ISO 4414:2010.

Furthermore, this equipment has been manufactured under the Riverhawk quality system per EN ISO 9001:2015

Consult the Declaration of Conformance included with the shipment of this equipment that identifies the authorized Riverhawk representative, applicable serial numbers, and appropriate signature.



215 Clinton Road
New Hartford, NY 13413
Tel: +1 315 768 4855
Fax: +1 315 768 4941
Email: info@riverhawk.com

CUSTOMER'S INFORMATION BOX
CONTENTS ARE INDEPENDENT OF RIVERHAWK DOCUMENT CONTROL

GE DRAWING NUMBER	REV
373A4009	

Appendix B1 - Hydraulic Fittings

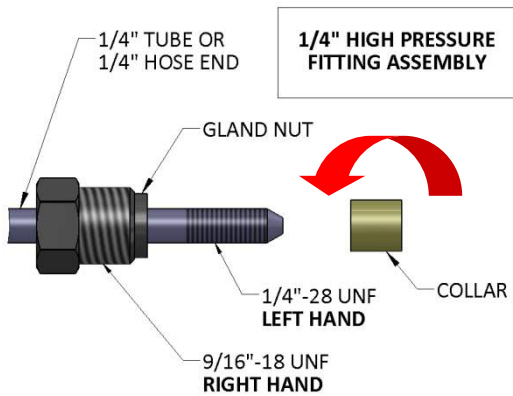

Illustration 1

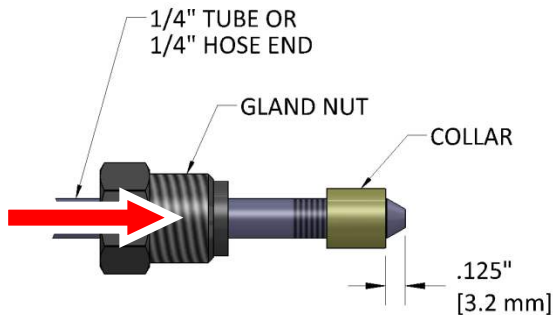

Illustration 2

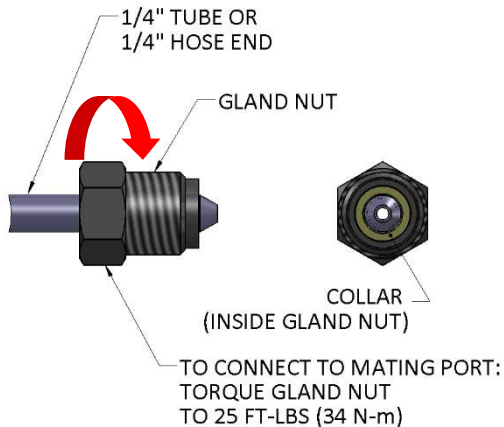

Illustration 3

Riverhawk tensioners use a 1/4" High Pressure port to connect its hydraulic hoses. The hose connector is made from a three piece assembly: a gland nut, a collar, and a 1/4" tube or 1/4" hose end. (See Illustration 1)

To assembly the fitting, slide the gland nut over the 1/4" tube or 1/4" hose end. Turn the collar counter-clockwise (**left hand** thread) on to the tube or hose end as shown in Illustration 1.

The collar should be placed .125" (3.2 mm) from the tip of the cone. (See Illustration 2) It may be necessary to adjust this collar with a set of vise-grip pliers. Be careful to not strip the threads off the tube or hose end.

Slide the gland nut down over the collar. (See Illustration 3) Insert the 1/4" tube or 1/4" hose end into tensioner or hydraulic pump. While firmly holding the tube or hose end to stop it from rotating, turn the gland nut clockwise (**right hand** thread) and torque the gland nut to 25 FT-LBS (34 N-m).

Tips:

- Make sure all parts are clean and free from debris.
- Protect the cone on the end of the 1/4" tube or 1/4" hose end from scratches as this is the sealing surface.
- Replace red plastic caps when finished to protect the threads and cone.



215 Clinton Road
 New Hartford, NY 13413
 Tel: +1 315 768 4855
 Fax: +1 315 768 4941
 Email: info@riverhawk.com

CUSTOMER'S INFORMATION BOX
 CONTENTS ARE INDEPENDENT OF RIVERHAWK DOCUMENT CONTROL

GE DRAWING NUMBER	REV
373A4009	

Appendix B2 – Puller Screw Release Tape Installation

Reference: GT-6516 (GE 373A4080)

Caution

Apply a light coat of clean turbine oil or a spray lubricant to the puller screw. This procedure will ease assembly and assure positive mating of the threads before tightening. Do not use “Never Seize” on the conical threads.

To use puller screw release tape

-During tensioner assembly

1. Following steps in the tensioner installation manual, before inserting the puller screw into the stud.
2. Insert a single puller screw release tape onto the internal thread of the stud leaving approximately 1/8” [3mm] sticking out of the end of the stud. (see picture below)
3. Insert puller screw into stud, per instruction manual and continue assembly of the tensioner.

-After tensioning and removal of tensioner from stud

1. Follow appropriate tensioner installation manual for disassembly of the tensioner.
2. Once tensioner is removed, clean studs internal thread and puller screw external thread to remove all debris left behind by puller screw release tape using brass power brush (GT-4253)

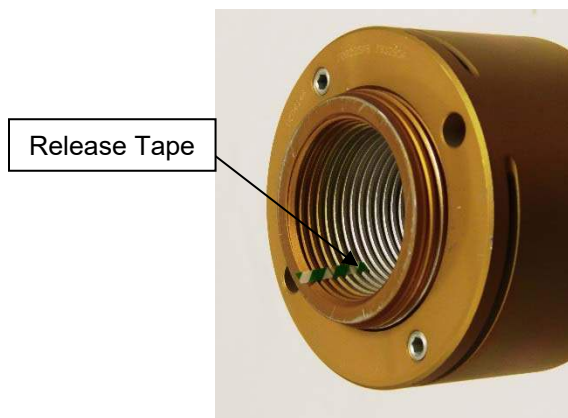

-Release tape should only be used for stud installation; puller screw engagement does not require the use of release tape during de-tensioning of the studs.

-Do not substitute for Riverhawk release tape, contact Riverhawk for support (+1) 315-768-4855 or www.Riverhawk.com



215 Clinton Road
New Hartford, NY 13413
Tel: +1 315 768 4855
Fax: +1 315 768 4941
Email: info@riverhawk.com

CUSTOMER'S INFORMATION BOX
CONTENTS ARE INDEPENDENT OF RIVERHAWK DOCUMENT CONTROL

GE DRAWING NUMBER	REV
373A4009	

Revision R
Page 35 of 37

Appendix C1

STRETCH RECORD SHEET FOR
THE GAS TURBINE TO LOAD COUPLING

TURBINE NUMBER:

DATE:

TECHNICIAN:

SUPERVISOR:

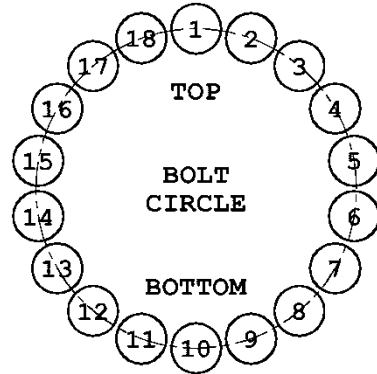

HOLE NUMBER	STARTING LENGTH	FINAL LENGTH	FINAL STRETCH
1			
10			
2			
11			
3			
12			
4			
13			
5			
14			
6			
15			
7			
16			
8			
17			
9			
18			

CUSTOMER'S INFORMATION BOX
CONTENTS ARE INDEPENDENT OF RIVERHAWK DOCUMENT CONTROL

GE DRAWING NUMBER	REV
373A4009	



215 Clinton Road
New Hartford, NY 13413
Tel: +1 315 768 4855
Fax: +1 315 768 4941
Email: info@riverhawk.com

Appendix C2

STRETCH RECORD SHEET FOR
THE LOAD COUPLING TO GENERATOR

TURBINE NUMBER:

DATE:

TECHNICIAN:

SUPERVISOR:

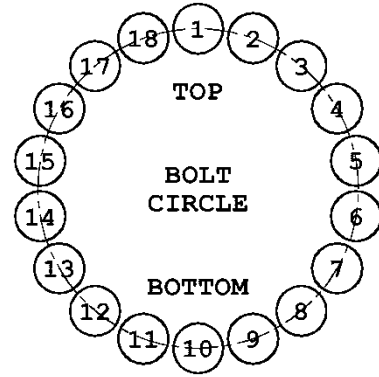

HOLE NUMBER	STARTING LENGTH	FINAL LENGTH	FINAL STRETCH
1			
10			
2			
11			
3			
12			
4			
13			
5			
14			
6			
15			
7			
16			
8			
17			
9			
18			

CUSTOMER'S INFORMATION BOX
CONTENTS ARE INDEPENDENT OF RIVERHAWK DOCUMENT CONTROL

GE DRAWING NUMBER	REV
373A4009	



215 Clinton Road
New Hartford, NY 13413
Tel: +1 315 768 4855
Fax: +1 315 768 4941
Email: info@riverhawk.com