



INSTRUCTION MANUAL IM-101
For Gas Turbine and Steam Turbine
Tensioned Studs and Nuts

Applicable Bolting Connections

- Fr. 6FA Gas Turbine to 6FA Generator
- Fr. 6FA Gas Turbine to Gearbox
- Gearbox to 6FA Generator
- Steam Turbine to 6FA Generator

Applicable GE Ordering Sheet Part Numbers

356A3954P001	381A6841P001	381A6850P006
356A3954P003		381A6850P007
356A3954P004	381A6850P001	381A6850P008
356A3954P005	381A6850P002	381A6850P010
356A3954P006	381A6850P003	381A6850P011
	381A6850P004	381A6850P014
361A6147P001	381A6850P005	381A6850P015

CUSTOMER'S INFORMATION BOX

CONTENTS ARE INDEPENDENT OF RIVERHAWK DOCUMENT CONTROL

GE Power & Water		GENERAL ELECTRIC COMPANY	
<u>VENDOR SUPPLIED</u>			
GE NOT TO REVISE. GE REVISION LEVEL IS SHOWN ON THIS APPLIQUE. THIS DOCUMENT IS FILED UNDER THE GE DRAWING NUMBER.			
THIS DOCUMENT SHALL BE REVISED IN ITS ENTIRETY. ALL SHEETS OF THIS DOCUMENT ARE THE SAME REVISION LEVEL AS INDICATED IN THIS VENDOR SUPPLIED DRAWING APPLIQUE.			
MLI: _____ OF _____			
GE SIGNATURES	DATE	GE DRAWING NUMBER	REV
CHECKED:		373A4008	
ISSUED:			

The Riverhawk Company reserves the right to update this document without dissemination or notice. The latest revision may be obtained by contacting Riverhawk Company or thru www.riverhawk.com.



Repairs – Rentals
Field Service

215 Clinton Road
New Hartford, NY 13413
Tel: +1 315 768 4855
Fax: +1 315 768 4941
Email: info@riverhawk.com

Table of Contents

Section	Description	Page Number
1.0	Cautions and Safety Warnings	3
2.0	Scope and GE Part Number Cross Reference	5
3.0	Quick Checklist	7
4.0	General Preparations	10
5.0	Hardware Set Preparations	13
6.0	Stud and Nut Assembly	16
7.0	Hydraulic Tensioner Equipment Assembly	18
8.0	Assembly of Tensioner on Stud	20
9.0	Stud Tensioning	30
10.0	Thread Locking	33
11.0	Stud and Nut Removal	35
12.0	Storage Instructions	38
13.0	Frequently Asked Questions	39
14.0	Revision History	42
Appendix A1	EC Declaration of Conformity	44
Appendix A2	UKCA Declaration of Conformity	45
Appendix B1	Hydraulic Fittings	46
Appendix C1	27-Bolt Tensioning Pattern (GT-LC) Record Sheet	47
Appendix C2	27-Bolt Tensioning Pattern (LC-LG) Record Sheet	48
Appendix C3	18-Bolt Tensioning Pattern (LG-GEN) Record Sheet	49



215 Clinton Road
 New Hartford, NY 13413
 Tel: +1 315 768 4855
 Fax: +1 315 768 4941
 Email: info@riverhawk.com

CUSTOMER'S INFORMATION BOX
 CONTENTS ARE INDEPENDENT OF RIVERHAWK DOCUMENT CONTROL

GE DRAWING NUMBER	REV
373A4008	

1.0 Cautions and Safety Warnings

WARNING

Improper tool use and the failure to follow the correct procedures are the primary root causes of tool failures and personal injuries. A lack of training or experience can lead to incorrect hardware installation or incorrect tool use. Only trained operators with careful, deliberate actions should use hydraulic tensioners. Contact Riverhawk Company with any training needs.

WARNING

Risk of high pressure hydraulic fluid injection. Riverhawk tools operate under high pressure. Thoroughly inspect all hoses and connections for damage or leaks prior to using this equipment.

CAUTION

Personal injury and equipment damage can occur if the proper health and safety codes and procedures are not followed. Contact the site's health and safety office to determine all applicable safety rules and regulations.

WARNING

The proper personal protective equipment must be worn at all times. Riverhawk recommends at a minimum, safety glasses, long sleeve shirt, hard hat, heavy work gloves, and steel toe shoes.

CAUTION

It is especially important to check the condition of the conical thread used to tension the stud. Thread damage from previous abuse can lead to failure of the stud or tensioning equipment

CAUTION

Riverhawk recommends that the tensioner should be returned to Riverhawk for periodic inspections. Replacement of obsolete tensioners is recommended. Functional upgrades are also recommended. The Riverhawk Service Returns Coordinator should be notified 3-6 months prior to a planned outage to schedule an inspection service.

WARNING

A damaged burst disc must be replaced with a with a burst disc of the same design and pressure rating. Do not substitute a damaged burst disc with a different disc type, a different pressure rating, or a foreign object.



215 Clinton Road
New Hartford, NY 13413
Tel: +1 315 768 4855
Fax: +1 315 768 4941
Email: info@riverhawk.com

CUSTOMER'S INFORMATION BOX

CONTENTS ARE INDEPENDENT OF RIVERHAWK DOCUMENT CONTROL

GE DRAWING NUMBER	REV
373A4008	

Revision AB
Page 3 of 49

WARNING

To avoid failure, ensure safety, and proper operation, the tensioner assembly must be installed on a stud in the flange before bleeding and pressurizing the tensioner. Do not use the tensioner at any pressure unless the tool is installed on a stud in a flange.

CAUTION

Do not over extend the tensioner. Over extension can cause the piston to lose its seal and leak oil.

CAUTION

Personal injury and equipment damage can occur if the puller screw is not securely engaged with the tapered threads of the stud. Proper engagement is achieved when the puller screw is tight in the stud and the tensioner assembly is free to turn.

WARNING

The safety cage must be in place at all times. When the tensioner is pressurized, hands must be kept out of designated areas to avoid any potential for personal injury.

CAUTION

Before threading the puller screw into the stud, carefully check the cleanliness of both the stud's and the puller screw's conical threads. Apply a light coat of clean turbine oil or a spray lubricant to the puller screw. This procedure will ease assembly and assure positive mating of the threads before tightening. Do not use "Never Seize" on the conical threads.

CAUTION

Do not tighten the nut while the tool is coming up to pressure; wait until pressure is achieved before attempting to tighten the nut with the spanner ring. If the tool is not properly installed, the tool could jump off the stud while coming up to pressure.

CAUTION

Do not exceed the maximum pressure marked on the tensioner. Excessive pressure can damage the stud and puller screw.

WARNING

FIRE HAZARD: DO NOT heat when tensioner assembly is in place. Personal injury or equipment damage may occur. Use of an Oxy-Acetylene torch is not recommended



215 Clinton Road
New Hartford, NY 13413
Tel: +1 315 768 4855
Fax: +1 315 768 4941
Email: info@riverhawk.com

CUSTOMER'S INFORMATION BOX

CONTENTS ARE INDEPENDENT OF RIVERHAWK DOCUMENT CONTROL

GE DRAWING NUMBER	REV
373A4008	

2.0 Scope

This document describes the procedure to be used to install the stud and nut sets supplied by the Riverhawk Company in the flanges at the Turbine/Coupling, Coupling/Gearbox and Gearbox/Generator connections.

The various frame configurations covered in this manual are listed in Sections 2.1 through 2.5 with differences as related to connective hardware defined. Listed also are the pertinent hardware drawings (HF-xxxx). These drawings as well as tooling drawings (HT-xxxx) form part of this manual.

2.1 Frame 6FA Gas Turbine to 6FA Generator

GE PART NUMBER	RIVERHAWK P/N	GE VENDOC P/N
GE 356A3954P001	HF-0737	GE 359B2521
GE 356A3954P004	HF-0737	GE 359B2521

The hydraulic tools used for installation and removal are Riverhawk HT-0406 (Lucas manufactured load coupling) or Riverhawk HT-5618 (Kop-flex manufactured load coupling) and HT-0716 (generator).

GE PART NUMBER	RIVERHAWK P/N	GE VENDOC P/N
GE 381A6850P001	HF-0737	GE 359B2521

The hydraulic tools used for installation and removal are Riverhawk HT-0406 (Goodrich manufactured load coupling) or Riverhawk HT-4856 (Kop-Flex manufactured load coupling) and HT-0716 (generator).

GE PART NUMBER	RIVERHAWK P/N	GE VENDOC P/N
GE 381A6850P002	HF-0737	GE 359B2521

The hydraulic tools used for installation and removal are Riverhawk HT-0406 (Goodrich manufactured load coupling) and HT-0716 (generator).

GE PART NUMBER	RIVERHAWK P/N	GE VENDOC P/N
GE 381A6850P003	HF-0737	GE 359B2521

The hydraulic tools used for installation and removal are Riverhawk HT-4856 (Kop-Flex manufactured load coupling) and HT-0716 (generator).



215 Clinton Road
 New Hartford, NY 13413
 Tel: +1 315 768 4855
 Fax: +1 315 768 4941
 Email: info@riverhawk.com

CUSTOMER'S INFORMATION BOX
 CONTENTS ARE INDEPENDENT OF RIVERHAWK DOCUMENT CONTROL

GE DRAWING NUMBER	REV
373A4008	

Instruction Manual IM-101

GE PART NUMBER	RIVERHAWK P/N	GE VENDOC P/N
GE 381A6850P014	HF-0737	GE 359B2521

The hydraulic tools used for installation and removal are Riverhawk HT-0406 (Goodrich manufactured load coupling) and HT-3334 (generator).

GE PART NUMBER	RIVERHAWK P/N	GE VENDOC P/N
GE 381A6850P015	HF-0737	GE 359B2521

The hydraulic tools used for installation and removal are Riverhawk HT-4856 (Kop-Flex manufactured load coupling) and HT-3334 (generator).

These hardware drawings depict the complete stud and nut package for both Turbine to Load Coupling (1-1/8" size, Qty 27) and Load Coupling to Gearbox (1-1/8" size, Qty 27) as well as Gearbox to Generator (2" size, Qty 18).

2.2 Frame 6FA Gas Turbine to Gearbox

GE PART NUMBER	RIVERHAWK P/N	GE VENDOC P/N
GE 356A3954P006	HF-3832	GE 359B2596

The hydraulic tools used for installation and removal is Riverhawk HT-0406 (Lucas manufactured load coupling).

These hardware drawings depict the complete stud and nut package for both Turbine to Load Coupling (1-1/8" size, Qty 27) and Load Coupling to Gearbox (1-1/8" size, Qty 27).

2.3 Gearbox to 6FA Generator

GE PART NUMBER	RIVERHAWK P/N	GE VENDOC P/N
GE 381A6850P004	HF-5204	GE 269B8695

The hydraulic tools used for installation and removal is Riverhawk HT-3334.

These hardware drawings depict the complete stud and nut package for the Gearbox to Generator (2" size, Qty 18).



215 Clinton Road
New Hartford, NY 13413
Tel: +1 315 768 4855
Fax: +1 315 768 4941
Email: info@riverhawk.com

CUSTOMER'S INFORMATION BOX
CONTENTS ARE INDEPENDENT OF RIVERHAWK DOCUMENT CONTROL

GE DRAWING NUMBER	REV
373A4008	

2.4 Steam Turbine to 6FA Generator

GE PART NUMBER	RIVERHAWK P/N	GE VENDOC P/N
GE 361A6147P001	HF-0748	GE 359B2504
GE 361A6147P002	HF-0748	GE 359B2504

The hydraulic tools used for installation and removal is Riverhawk HT-3334.

These hardware drawings depict the complete stud and nut package for the Gearbox to Generator (2" size, Qty 18).

2.5 Hydraulic Tooling

GE PART NUMBER	RIVERHAWK P/N	GE VENDOC P/N
GE 381A6841P001	HT-0406	GE 364B3418
	HT-0716	GE 359B2503
	MP-0130	GE 359B2506
GE 356A3954P005	HT-0406	GE 364B3418
	or HT-5618	GE 269B8741
	AP-0532	GE 359B2502
GE 381A6850P005	HT-3334	GE 359B2584
GE 381A6850P006	HT-0406	GE 364B3418
GE 381A6850P007	HT-4856	GE 269B8686
GE 381A6850P008	HT-0716	GE 359B2503
GE 381A6850P010	MP-0130	GE 359B2506
GE 381A6850P011	AP-0532	GE 359B2502

3.0 Quick Checklist

The following checklist is intended as a summary of the steps needed to use the Riverhawk-supplied equipment. New personnel or those experienced personnel who have not used the Riverhawk equipment recently are encouraged to read the entire manual.

EQUIPMENT INSPECTION

- Check oil level in hydraulic pump.
- Check air pressure at 80psi [5.5 bar] minimum. (For air-driven pumps)



215 Clinton Road
 New Hartford, NY 13413
 Tel: +1 315 768 4855
 Fax: +1 315 768 4941
 Email: info@riverhawk.com

CUSTOMER'S INFORMATION BOX
 CONTENTS ARE INDEPENDENT OF RIVERHAWK DOCUMENT CONTROL

GE DRAWING NUMBER	REV
373A4008	

- Check hydraulic hose for damage.
- Test pump.
- Inspect tensioner for any damage.

NUT AND STUD PREPARATION

- Inspect studs and nuts for any damage.
- Clean the studs and nuts.
- Measure stud lengths. (VERY IMPORTANT)
- Install studs and nuts (off-center) into the flange. Check hardware set drawing for stud direction.
- Set stick-out dimension on the coupling side of the flange.
- Hand tighten the nuts on turbine / generator side of flange.
- Verify stick-out measurement (**VERY IMPORTANT**)

TENSIONING (Bolt Installation)

- Check tensioner drawing for correct parts and part numbers.
- Apply a light coat of clean turbine oil or spray lubricant to the puller screw. **DO NOT USE "NEVER SEIZE" ON THE CONICAL THREADS.**
- Slide spanner ring over the puller screw.
- Install the tensioner on the stud in flange and slide spanner ring onto nut.
- Insert 1/2" hex Allen wrench into the back side of the stud.
- Tighten the puller screw. Then back off puller screw 1/2 a turn.



215 Clinton Road
New Hartford, NY 13413
Tel: +1 315 768 4855
Fax: +1 315 768 4941
Email: info@riverhawk.com

CUSTOMER'S INFORMATION BOX
CONTENTS ARE INDEPENDENT OF RIVERHAWK DOCUMENT CONTROL

GE DRAWING NUMBER	REV
373A4008	

- Retighten the puller screw and leave tight. **DO NOT BACK OFF PULLER SCREW.**
- Tighten puller nut and then back nut off two flats or 120 degrees to allow for stud stretch.
- Bleed the tensioner. **Do NOT bleed tensioner off of a stud! Damage to the tool will result!**
- Tension to 50%. Consult manual for correct pressure.
- Use the pin wrench in spanner ring to tighten nut.
- Release pressure, move to next stud in tensioning pattern.
- Repeat above steps at final pressure.
- Measure final stud length and record on stretch datasheets. Calculate stretch.
- Torque the nuts' set screws.

DETENSIONING (Stud Removal)

- Loosen nuts' set screws
- Inspect and clean studs' conical threads. **Do not continue until ALL debris is removed from the threads!** See instruction manual IM-220. **Do not try to use the tensioner to remove a damaged stud!**
- Apply a light coat of clean turbine oil or spray lubricant to the puller screw. **DO NOT USE "NEVER SEIZE" ON THE CONICAL THREADS.**
- Slide spanner ring over the puller screw.
- Install the tensioner on the stud.
- Install spanner ring into nut.
- Tighten the puller screw. Then back off puller screw 1/2 a turn.



215 Clinton Road
New Hartford, NY 13413
Tel: +1 315 768 4855
Fax: +1 315 768 4941
Email: info@riverhawk.com

CUSTOMER'S INFORMATION BOX
CONTENTS ARE INDEPENDENT OF RIVERHAWK DOCUMENT CONTROL

GE DRAWING NUMBER	REV
373A4008	

- Retighten the puller screw and leave tight. **DO NOT BACK OFF PULLER SCREW.**
- Tighten puller nut and then back nut off two flats or 120 degrees to allow for stud stretch.
- Bleed the tensioner. **Do NOT bleed tensioner off of a stud! Damage to the tool will result!**
- Apply final pressure.
- Loosen nut with the spanner ring and pin wrench.
- Move to next stud in the removal pattern.

4.0 General Preparations

Read and understand all instructions before installing and tensioning studs.

Operators should be trained or have previous experience using Riverhawk tensioning equipment. Training will minimize the chance of improper use of the equipment.

The hydraulic tooling including the hydraulic hoses should be inspected prior to use. Inspection guidelines are listed in the following sub-sections.

This equipment produces very high hydraulic pressures and very high forces. Operators must exercise caution and wear the appropriate personal protective equipment when handling and operating the hydraulic tooling.

High-pressure oil from the hydraulic pump pressurizes the tensioner which generates a very large force that actually stretches the stud. As the stud is stretched the nut lifts off the flange. The nut is then turned by hand using the supplied spanner ring. Once the nut is tight against the flange, the pressure in the tensioner is released. The hardware is now clamping the flange together.

4.1 Machine Preparation

The flange to be tensioned must be fully closed prior to positioning the studs in the flanges. There must be provisions for turning the shafts of the turbine, coupling, gearbox, and generator. Also, it will be advantageous to remove as many obstructions as possible from the flange area, such as speed probes and conduit.



215 Clinton Road
New Hartford, NY 13413
Tel: +1 315 768 4855
Fax: +1 315 768 4941
Email: info@riverhawk.com

CUSTOMER'S INFORMATION BOX
CONTENTS ARE INDEPENDENT OF RIVERHAWK DOCUMENT CONTROL

GE DRAWING NUMBER	REV
373A4008	

Revision AB
Page 10 of 49

4.2 Hardware – Balance

The studs are supplied in component balanced sets. A stud can be exchanged with another in its set without affected the overall balance of the equipment. Do not exchange a stud from one set with another stud from a different set. When shipped from Riverhawk, the studs are not assigned to any specific hole in the load coupling flange; this is optional and can be done at the installation site. The set size is determined by the relevant GE order drawing (see section 2.0).

The nuts are supplied in component balanced sets. A nut can be exchanged with another in its set without affecting the overall balance of the equipment. Do not exchange a nut from one set with another nut from a different set. When shipped from Riverhawk, the nuts are not assigned to any specific hole in the load coupling flange; this is optional and can be done at the installation site. The set size is determined by the relevant GE order drawing (see section 2.0).

A weight balance certification is supplied with each order. Store this certification in an appropriate location as it will be needed for the purchase of replacement equipment.

4.3 Tensioner – Care and Handling

When not in use, the tensioner shall be maintained in a clean environment and all caps and plugs for hydraulic openings and fittings must be in place.

Use ISO 32 grade oil.

When in use, the tensioner shall be protected from sand and grit.

See section 12 for long term storage requirements.

4.4 Hand Tools

Several hand wrenches and micrometers will be required to perform installation and measurement of the studs:

5/8" wrench
15/16" wrench
1" wrench
Set of Allen Wrenches

3' – 4' Breaker Bar
5" to 6" micrometer
8" to 9" micrometer



215 Clinton Road
New Hartford, NY 13413
Tel: +1 315 768 4855
Fax: +1 315 768 4941
Email: info@riverhawk.com

CUSTOMER'S INFORMATION BOX
CONTENTS ARE INDEPENDENT OF RIVERHAWK DOCUMENT CONTROL

GE DRAWING NUMBER	REV
373A4008	

Revision AB
Page 11 of 49

4.5 Riverhawk Tools

Hydraulic Tensioner Kit: HT-0406 Hydraulic Tensioner, 1-1/8"
(reference GE VENDOC 364B3418)

Note: Review section 2 to determine the correct tensioner to use.
HT-4856 Hydraulic Tensioner, 1-1/8"
(reference GE VENDOC 269B8686)

HT-5618 Hydraulic Tensioner, 1-1/8"
(reference GE VENDOC 269B8741)

HT-0716 Hydraulic Tensioner, 2"
(reference GE VENDOC 359B2503)

HT-3334 Hydraulic Tensioner, 2"
(reference GE VENDOC 359B2584)

Obsolete Hydraulic Tensioner Kits: HT-0141 Hydraulic Tensioner, 1-1/8"
(**OBSOLETE**, replaced by HT-5618)

HT-0245 Hydraulic Tensioner, 1-1/8"
(**OBSOLETE**, replaced by HT-0406)

HT-0251 Hydraulic Tensioner, 1-1/8"
(**OBSOLETE**, replaced by HT-0406)

HT-0174 Hydraulic Tensioner, 2"
(**OBSOLETE**, replaced by HT-0716)

HT-0252 Hydraulic Tensioner, 2"
(**OBSOLETE**, replaced by HT-0716)

Hydraulic Pump Kit: AP-0532 Air-operated Hydraulic Pump
(reference GE VENDOC 359B2502)

MP-0130 Manual Hand-operated Hydraulic Pump
(reference GE VENDOC 359B2506)

CAUTION

Riverhawk recommends that the tensioners be returned to Riverhawk for periodic inspections. Replacement of obsolete tensioners is recommended. Functional upgrades are



215 Clinton Road
New Hartford, NY 13413
Tel: +1 315 768 4855
Fax: +1 315 768 4941
Email: info@riverhawk.com

CUSTOMER'S INFORMATION BOX	
CONTENTS ARE INDEPENDENT OF RIVERHAWK DOCUMENT CONTROL	
GE DRAWING NUMBER	REV
373A4008	

also recommended. The Riverhawk Service Returns Coordinator should be notified 3-6 months prior to a planned outage to schedule an inspection service.

5.0 Hardware Set Preparations

5.1 Nut Preparation

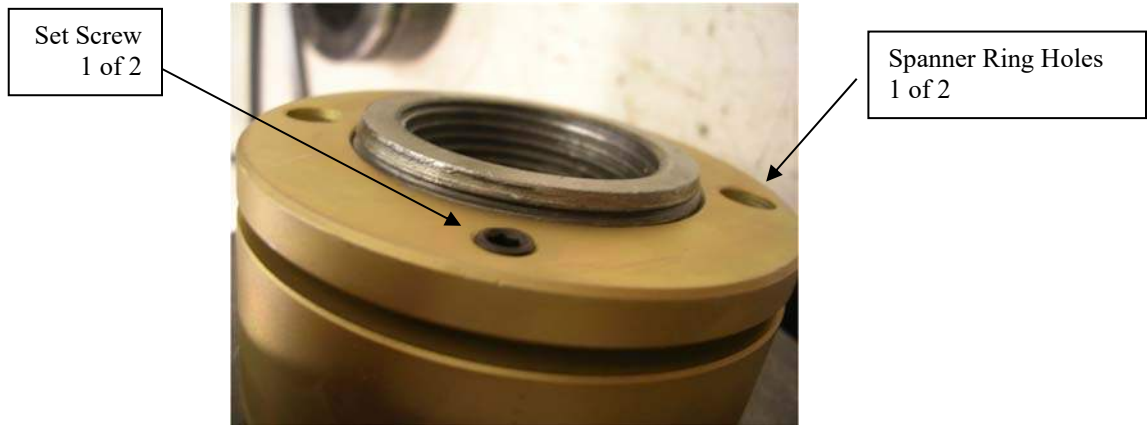

Picture 5A - Riverhawk Locknut

If there is any visible damage on a nut, do not use the nut and contact the Riverhawk Company for a replacement nut. Please be prepared to supply the turbine number, weight certification, and digital photographs for evaluation.

5.1.1 Nut Cleaning - New Installations

For new installations, the nuts should come sealed from the factory and will need no cleaning.

5.1.2 Nut Cleaning - Old Installations

Previously installed nuts require cleaning as follows: Wire brush using a petroleum-based solvent to remove any foreign material on the external surfaces and threads.

5.1.3 Nut Cleaning - Very Old Installations

If previous installations employed a thread-locking compound, which will be visible as a grayish-green residue, remove as much of this compound as possible. Finish the cleaning process by rinsing in a volatile solvent such as acetone and allow to dry.

Riverhawk Company strongly recommends replacing this style of nut with the current nut with a re-useable mechanical locking feature.



215 Clinton Road
New Hartford, NY 13413
Tel: +1 315 768 4855
Fax: +1 315 768 4941
Email: info@riverhawk.com

CUSTOMER'S INFORMATION BOX
CONTENTS ARE INDEPENDENT OF RIVERHAWK DOCUMENT CONTROL

GE DRAWING NUMBER	REV
373A4008	

5.2 Stud Preparation

Check the stud for any visible damage. If there is any visible damage, do not use the stud and contact the Riverhawk Company for a replacement stud. Please be prepared to supply the turbine number, weight certification, and digital photographs for evaluation.

CAUTION

It is especially important to check the condition of the conical thread used to tension the stud. Thread damage from previous abuse can lead to failure of the stud or tensioning equipment.

The conical threads of each stud must be clean of grit and dirt before installation or removal. This ensures the proper seating of the puller screw.

5.2.1 Stud Cleaning - New Installations

For new installations, the studs should come sealed from the factory and will need no cleaning.

5.2.2 Stud Cleaning - Old Installations

Previously installed studs may require cleaning. Clean conical threads should have a bright and shiny appearance.

If cleaning is required, follow these steps:

1. Blow out the threads with compressed air to remove loose debris and dry conical threads. Do not apply a solvent or other cleaning solution to the threads as this may chemically attack the stud.
2. Use Stud Cleaning Kit, GT-4354 or a similar 1/2" diameter Brass power brush.



Picture 5B - Brass Power Brush

3. Insert the brush into an electric drill and set drill to run in a counterclockwise direction at high speed.



215 Clinton Road
New Hartford, NY 13413
Tel: +1 315 768 4855
Fax: +1 315 768 4941
Email: info@riverhawk.com

CUSTOMER'S INFORMATION BOX

CONTENTS ARE INDEPENDENT OF RIVERHAWK DOCUMENT CONTROL

GE DRAWING NUMBER	REV
373A4008	

Revision AB
Page 14 of 49

4. Work the drill in a circular motion while moving the brush in and out to clean all of the threads. Try not to hold the brush in one place too long, so as not to remove the stud's protective coating.
5. Blow out the threads with compressed air to remove loosened debris.
6. Visually inspect threads for cleanliness. Threads should be bright and shiny.
7. Repeat if any dirt can be seen in the threads.
8. Inspect threads for any damage that may have been caused by previous installation.
9. Do **not** apply thread lubricants such as "Never Seize" to the stud's threads.
10. Finish the cleaning process by rinsing in a volatile solvent such as acetone and allow to dry.

5.2.3 Stud Cleaning - Very Old Installations

If previous installation employed a thread locking compound, which will be visible as a grayish-green residue, remove as much of this compound as possible from the stud's threads.

Finish the cleaning process by rinsing in a volatile solvent such as acetone and allow to dry.

5.3 Stud Length Measurement

Measure and record the initial lengths of the studs. The following suggestions will improve your results.

- **Plan to start and finish any flange in the same day.**
- **Studs and flange must be at the same temperature.**
- **Number each stud with a marker for later stretch measurement tracking.**
- **Mark the location of measurement on stud end with a permanent marker.**
- **Measure each stud to nearest 0.001 inch (.01 mm).**
- **Record each measurement on the supplied record sheets.**
- **Do not allow the measuring instruments to sit in the sun.**
- **The same person should make all measurements.**



215 Clinton Road
New Hartford, NY 13413
Tel: +1 315 768 4855
Fax: +1 315 768 4941
Email: info@riverhawk.com

CUSTOMER'S INFORMATION BOX
CONTENTS ARE INDEPENDENT OF RIVERHAWK DOCUMENT CONTROL

GE DRAWING NUMBER	REV
373A4008	

6.0 Stud and Nut Assembly

Refer to the hardware assembly drawing (HF-xxxx) listed in Section 2.0 of this manual.

1. Assemble the cylindrical nut to the internal, conical thread end of the stud.
2. Slide the stud and cylindrical nut assembly into the flange as shown in Figures 6A, 6B, 6C, and 6D.

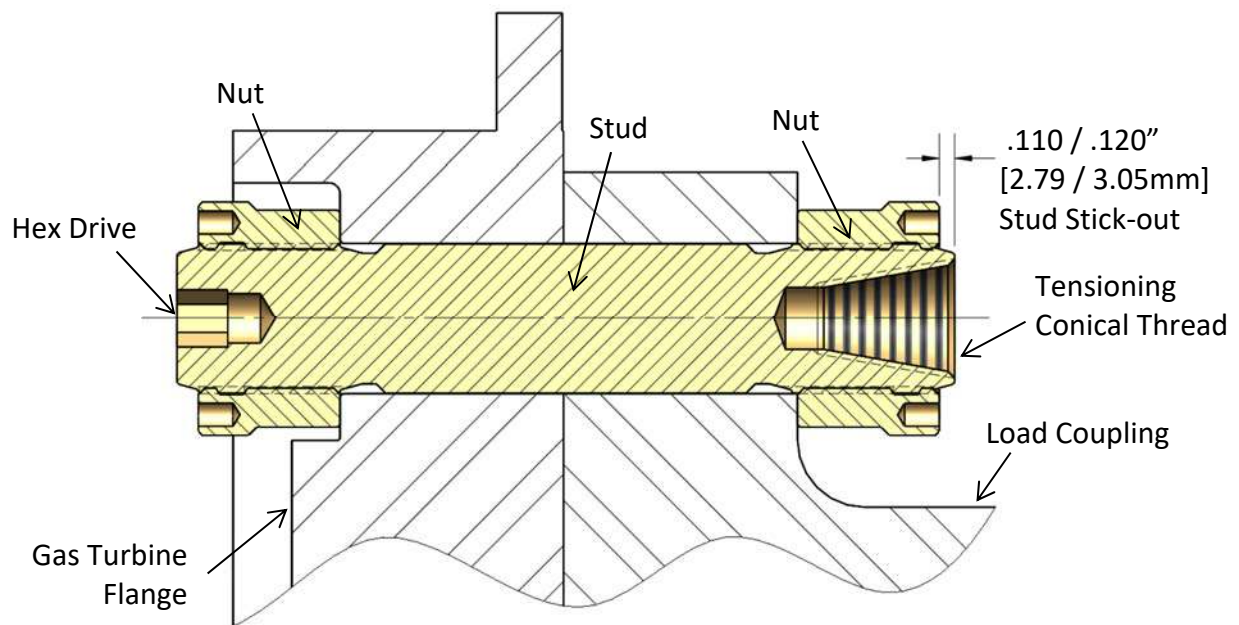

Figure 6A – Cross-section View of Gas Turbine to Load Coupling Bolted Flange Connection



215 Clinton Road
 New Hartford, NY 13413
 Tel: +1 315 768 4855
 Fax: +1 315 768 4941
 Email: info@riverhawk.com

CUSTOMER'S INFORMATION BOX

CONTENTS ARE INDEPENDENT OF RIVERHAWK DOCUMENT CONTROL

GE DRAWING NUMBER	REV
373A4008	

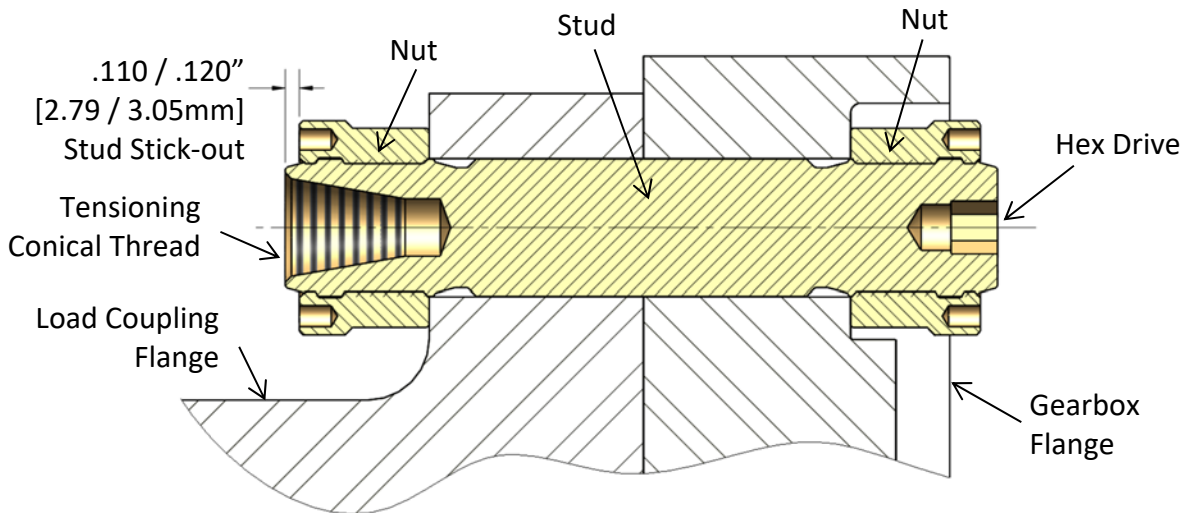

Figure 6B – Cross-section View of Load Coupling to Gearbox Bolted Flange Connection

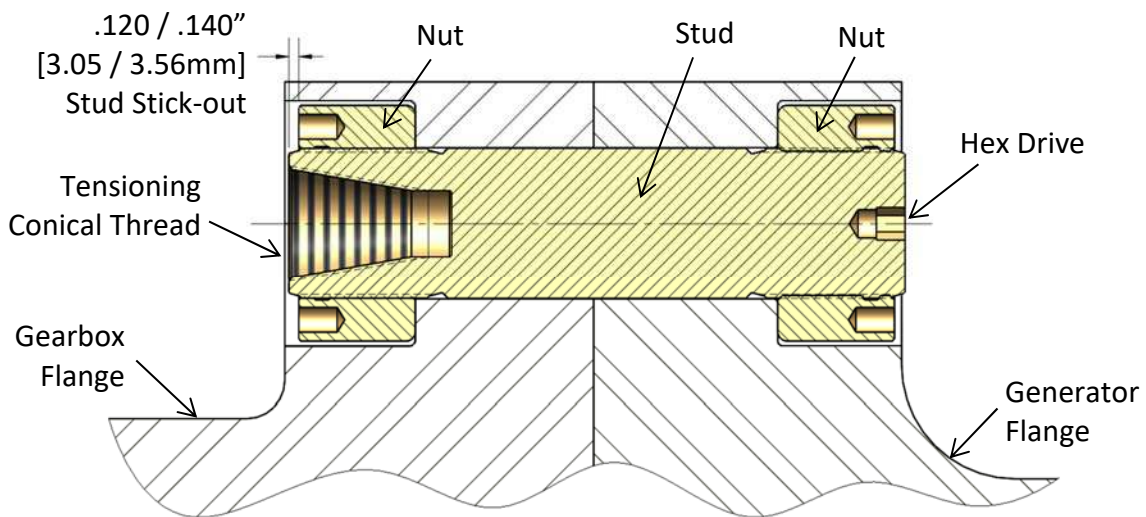

Figure 6C – Cross-section View of Gearbox to Generator Bolted Flange Connection



215 Clinton Road
 New Hartford, NY 13413
 Tel: +1 315 768 4855
 Fax: +1 315 768 4941
 Email: info@riverhawk.com

CUSTOMER'S INFORMATION BOX
 CONTENTS ARE INDEPENDENT OF RIVERHAWK DOCUMENT CONTROL

GE DRAWING NUMBER	REV
373A4008	

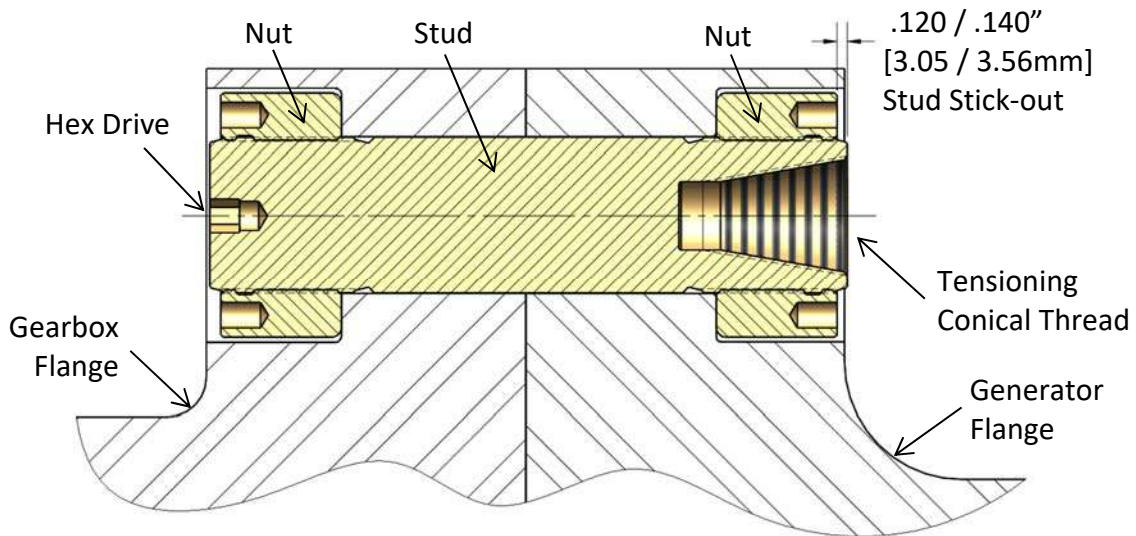

Figure 6D – Cross-section View of Gearbox to Generator Bolted Flange Connection

3. Install the other nut on the backside.
4. Adjust the nut/stud assembly so that the stud sticks out (protrudes) from the face of the nut the amount shown. Best practice is to verify the stud stick-out dimension with the hardware set drawing for your application (see section 2). If you don't have a hardware set drawing, it can be found in the GE Vendocs system or contact Riverhawk Company.

SETTING THE STUD STICK-OUT IS CRITICAL FOR PROPER TENSIONER OPERATION. A metal stick-out gage may be provided with the tensioner to assist the operator in setting the protrusion dimension.

5. Hand tighten the assembly to a snug fit.
6. Recheck the stud stick-out length. If the stick-out length does not match the hardware drawing, adjust the nuts as necessary.

7.0 Hydraulic Tensioner Equipment Assembly

7.1 Hydraulic Equipment Inspection



215 Clinton Road
 New Hartford, NY 13413
 Tel: +1 315 768 4855
 Fax: +1 315 768 4941
 Email: info@riverhawk.com

CUSTOMER'S INFORMATION BOX
 CONTENTS ARE INDEPENDENT OF RIVERHAWK DOCUMENT CONTROL

GE DRAWING NUMBER	REV
373A4008	

7.1.1 Hydraulic Tensioner Inspection

CAUTION

Riverhawk recommends that the tensioner be returned to Riverhawk for periodic inspections. Replacement of obsolete tensioners is recommended. Functional upgrades are also recommended. The Riverhawk Service Returns Coordinator should be notified 3-6 months prior to a planned outage to schedule an inspection service.

Do **not** bleed the air from the hydraulic lines and tensioner at this time. See section 8 for bleeding instructions on when to bleed the air from the hydraulic lines.

WARNING

To avoid failure, ensure safety, and proper operation, the tensioner assembly must be installed on a stud in the flange before bleeding and pressurizing the tensioner. Do not use the tensioner at any pressure unless the tool is installed on a stud in a flange.

Check puller screw usage life with Riverhawk service bulletin SB-08001.

Clean puller screw and check for any debris and dents.

Puller screw should be free to rotate and move back and forth.

Seam between cylinders closed tightly.

Inspect the tensioner guard for any signs of damage including cracked welds. Any guards modified in the field should be replaced. Bent guards should be replaced.

Inspect the outside of the tensioner for discoloration patterns that may indicate submersion and internal damage.

Perform an inventory of the loose equipment supplied with the tensioner. An inventory list is provided on the tensioner's technical drawing (for example Riverhawk HT-xxxx). Replacement parts are available from Riverhawk.

7.1.1.1 Hydraulic Tensioner's Burst Disc Replacement

The hydraulic tensioner's burst disc is a key element in the overall safe use of the hydraulic tensioner.

Each tensioner is shipped from our factory with one burst disc already installed in the tensioner and with another spare disc for field replacement. Extra burst discs are available from Riverhawk for replacement purposes.



215 Clinton Road
New Hartford, NY 13413
Tel: +1 315 768 4855
Fax: +1 315 768 4941
Email: info@riverhawk.com

CUSTOMER'S INFORMATION BOX	
CONTENTS ARE INDEPENDENT OF RIVERHAWK DOCUMENT CONTROL	
GE DRAWING NUMBER	REV
373A4008	

To replace a damaged burst disc:

1. Remove the hydraulic port's dispersion nut, compression ring, and damaged burst disc.
2. Discard the damaged burst disc.
3. Clean the dispersion nut, compression ring, new burst disc, and the hydraulic port with a solvent to ensure a dirt-free installation.
4. Reassemble new burst disc, compression ring, and dispersion nut into the same hydraulic port.

Warning

A damaged burst disc must be replaced with a with a burst disc of the same design and pressure rating. Do not substitute a damaged burst disc with a different disc type, a different pressure rating, or a foreign object.

7.1.2 Hydraulic Pump Kit Inspection

Refer to the Hydraulic Pump Kit Instruction Manual, IM-293 (GE VENDOC 373A4058). The latest revision may be obtained by contacting Riverhawk Company or thru www.riverhawk.com.

7.1.3 Hydraulic Hose Inspection

Check the hydraulic hose for any damage including bent hose ends and split outer lining. If any damaged is found, replace the hose immediately by contacting the Riverhawk Company.

7.2 Hydraulic Fittings

Information on the correct assembly of the hydraulic pump's and hydraulic hose's hydraulic fittings can be found in Appendix B1.

8.0 Assembly of Tensioner on Stud

Two types of Tensioner Kits will be encountered in the field. They are most readily identified by the safety cages that they employ. One cage is separate from the tensioner and the other is integral. Other design differences and operational characteristics are defined in Sections 8.1 and 8.2 which follow.

Assemble the hydraulic pump with its hose to the tensioner and bleed out the air per following instructions in section 8.3.



215 Clinton Road
New Hartford, NY 13413
Tel: +1 315 768 4855
Fax: +1 315 768 4941
Email: info@riverhawk.com

CUSTOMER'S INFORMATION BOX
CONTENTS ARE INDEPENDENT OF RIVERHAWK DOCUMENT CONTROL

GE DRAWING NUMBER	REV
373A4008	

Refer to the hardware assembly drawing (HF-xxxx) listed in Section 2.0 of this manual and the tensioner assembly drawing (HT-xxxx) listed in Section 4.5 of this manual to determine which side of the flange the tensioner must be located on in order to use the tensioner properly.

8.1 Assembly of Tensioner with Separate Safety Cage

Note: This is an obsolete tensioner design and has been fully replaced by the integral safety cage tensioner designs. Riverhawk strongly recommends upgrading to the integral safety cage design.

Assembly sequence is as follows:

1. Open the hydraulic return valve on the pump to allow hydraulic fluid to be pushed back from the tensioner into the pump reservoir. (This is automatic on the air-operated hydraulic pump)
2. Place the spanner ring on the puller-side nut.
3. Apply a light coat of clean turbine oil or a spray lubricant to the puller screw. Do not use "Never Seize" on the conical threads.
4. Place and hold the tensioner over the end to be tightened.
5. Insert the puller screw through the tensioner into the tapered thread of the stud and hand tighten
6. **Be sure not to cross-thread the assembly**
7. Tighten the puller screw using an open-end wrench and spanner or Allen wrench, depending on hardware configuration, on the opposite end of the stud (DO NOT WRENCH THE NUT).
8. At this point the puller screw must be tight in the stud and the tensioner assembly **MUST BE FREE TO ROTATE.**

Note: If the tool is not free to rotate when the puller screw is tight, then either: (1) the piston is not fully retracted; open the valve on the pump and retighten the puller screw. Or (2), the nuts must be repositioned so that the stud is shifted slightly more on the tensioner side. This can be done as follows:

1. Slightly loosen the puller screw.
2. Back the nut opposite the tensioner off about 1/2 turn.
3. Tighten the puller screw-side nut to take up the slack.
4. Retighten the puller screw per above and check for looseness of tool.



215 Clinton Road
New Hartford, NY 13413
Tel: +1 315 768 4855
Fax: +1 315 768 4941
Email: info@riverhawk.com

CUSTOMER'S INFORMATION BOX
CONTENTS ARE INDEPENDENT OF RIVERHAWK DOCUMENT CONTROL

GE DRAWING NUMBER	REV
373A4008	

8.2 Assembly of Tensioner with Integral Safety Cage

This assembly has the following features which should make stud tensioning safer and easier.

- The safety cage is integral (bolted) to the tensioner
- The hydraulic piston is spring loaded to retract
- The puller screw is a 2-piece design. This requires that the operator tighten the puller screw into the stud and then install a puller nut.

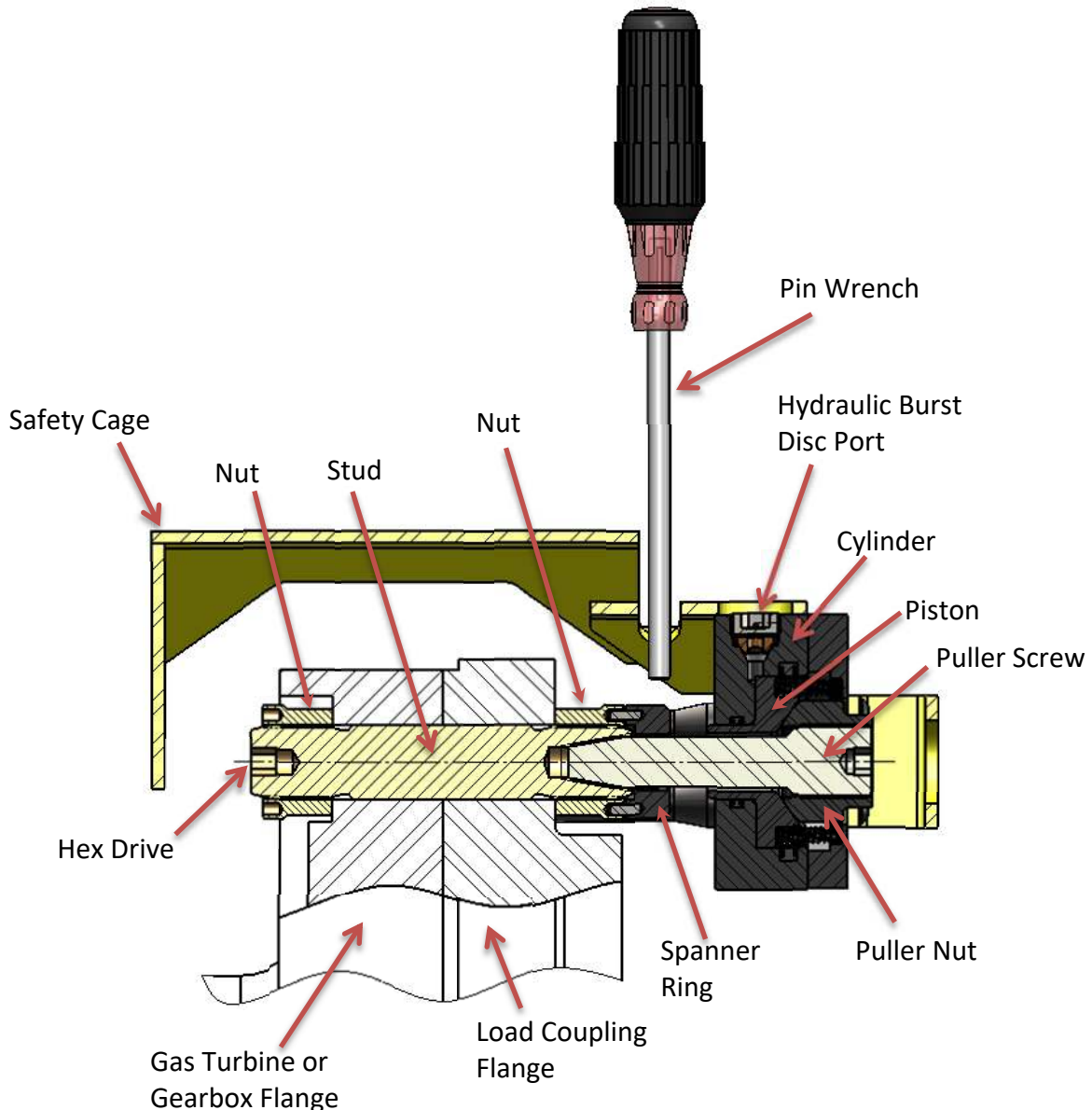

Figure 8A – Cross-section View of HT-0406 on 6FA Gas Turbine Load Coupling Flange

CUSTOMER'S INFORMATION BOX

CONTENTS ARE INDEPENDENT OF RIVERHAWK DOCUMENT CONTROL

GE DRAWING NUMBER	REV
373A4008	



215 Clinton Road
 New Hartford, NY 13413
 Tel: +1 315 768 4855
 Fax: +1 315 768 4941
 Email: info@riverhawk.com

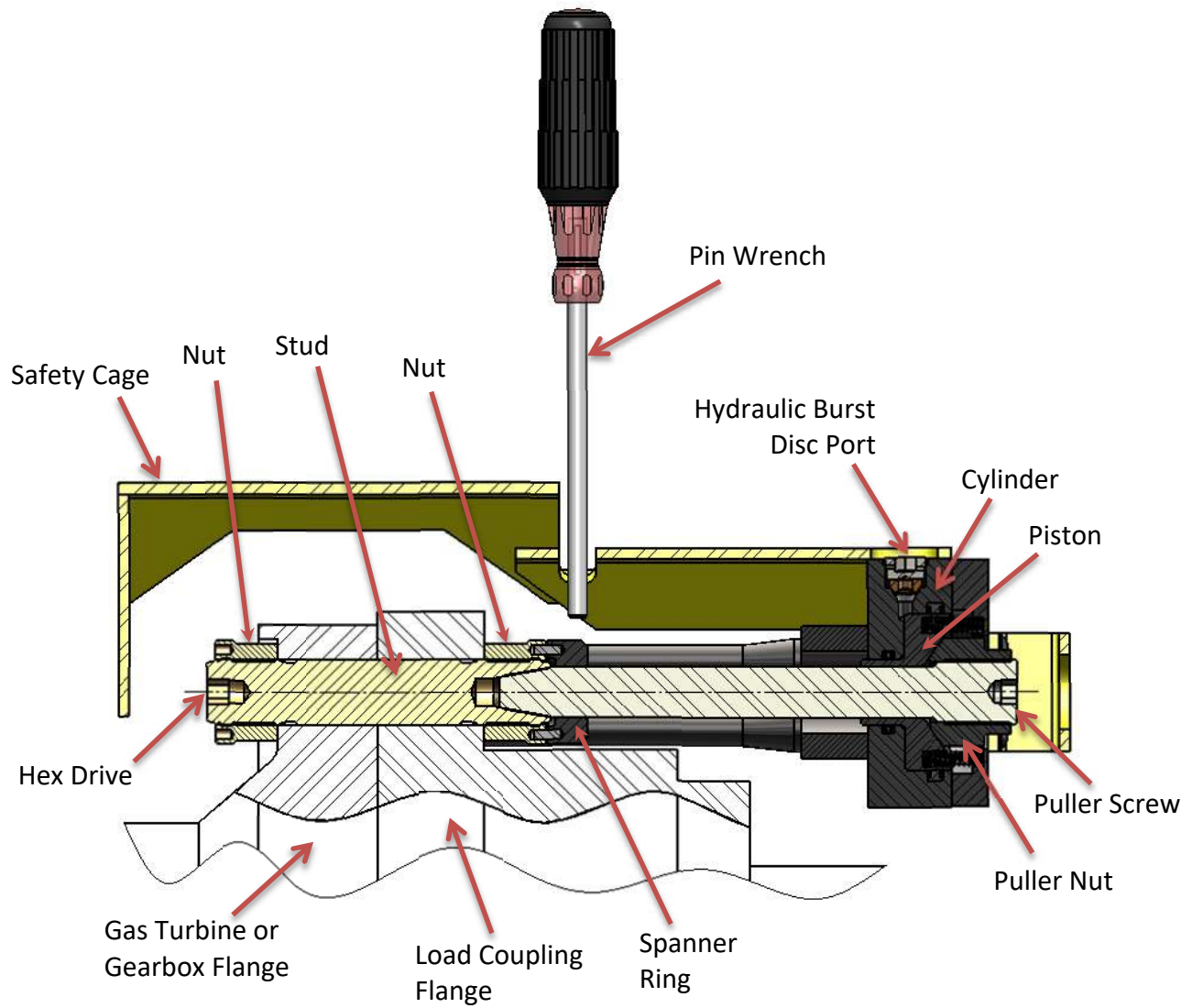

Figure 8B – Cross-section View of HT-4856 on 6FA Gas Turbine Load Coupling Flange



215 Clinton Road
 New Hartford, NY 13413
 Tel: +1 315 768 4855
 Fax: +1 315 768 4941
 Email: info@riverhawk.com

CUSTOMER'S INFORMATION BOX
 CONTENTS ARE INDEPENDENT OF RIVERHAWK DOCUMENT CONTROL

GE DRAWING NUMBER	REV
373A4008	

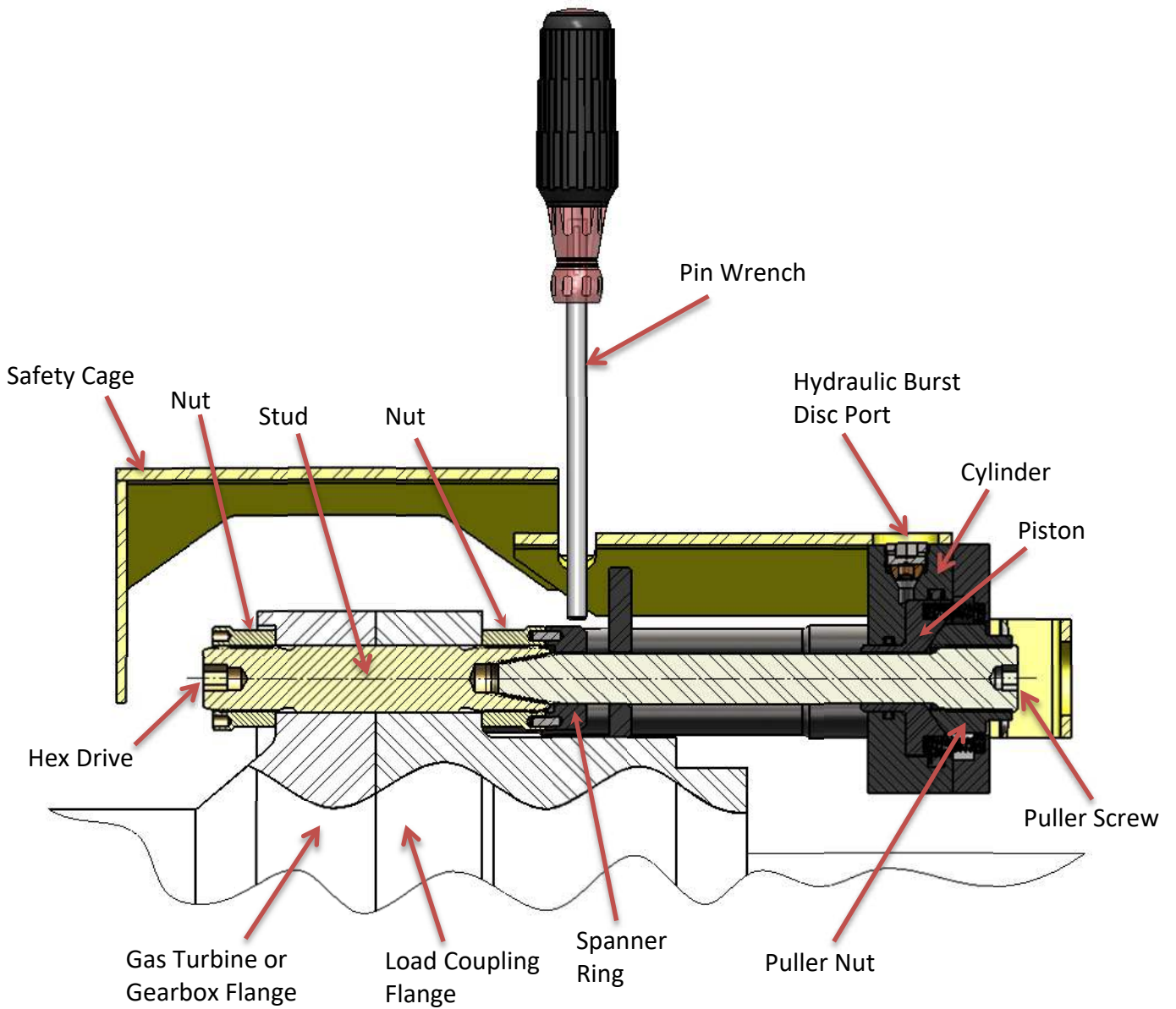

Figure 8C– Cross-section View of HT-5618 on 6FA Gas Turbine Load Coupling Flange



215 Clinton Road
 New Hartford, NY 13413
 Tel: +1 315 768 4855
 Fax: +1 315 768 4941
 Email: info@riverhawk.com

CUSTOMER'S INFORMATION BOX
 CONTENTS ARE INDEPENDENT OF RIVERHAWK DOCUMENT CONTROL

GE DRAWING NUMBER	REV
373A4008	

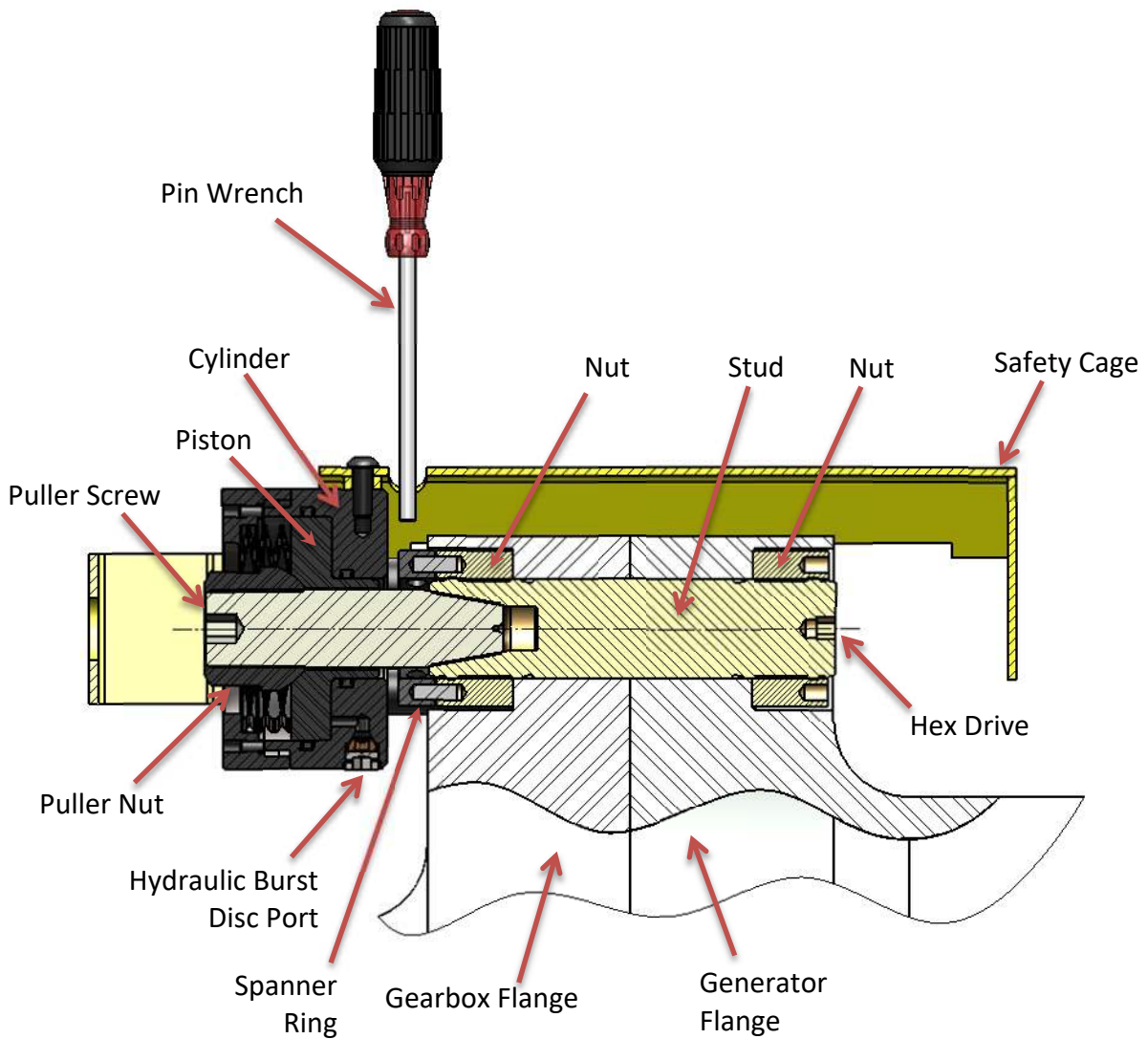

Figure 8D – Cross-section View of HT-0716 on 6FA Gearbox Flange



215 Clinton Road
 New Hartford, NY 13413
 Tel: +1 315 768 4855
 Fax: +1 315 768 4941
 Email: info@riverhawk.com

CUSTOMER'S INFORMATION BOX
 CONTENTS ARE INDEPENDENT OF RIVERHAWK DOCUMENT CONTROL

GE DRAWING NUMBER	REV
373A4008	

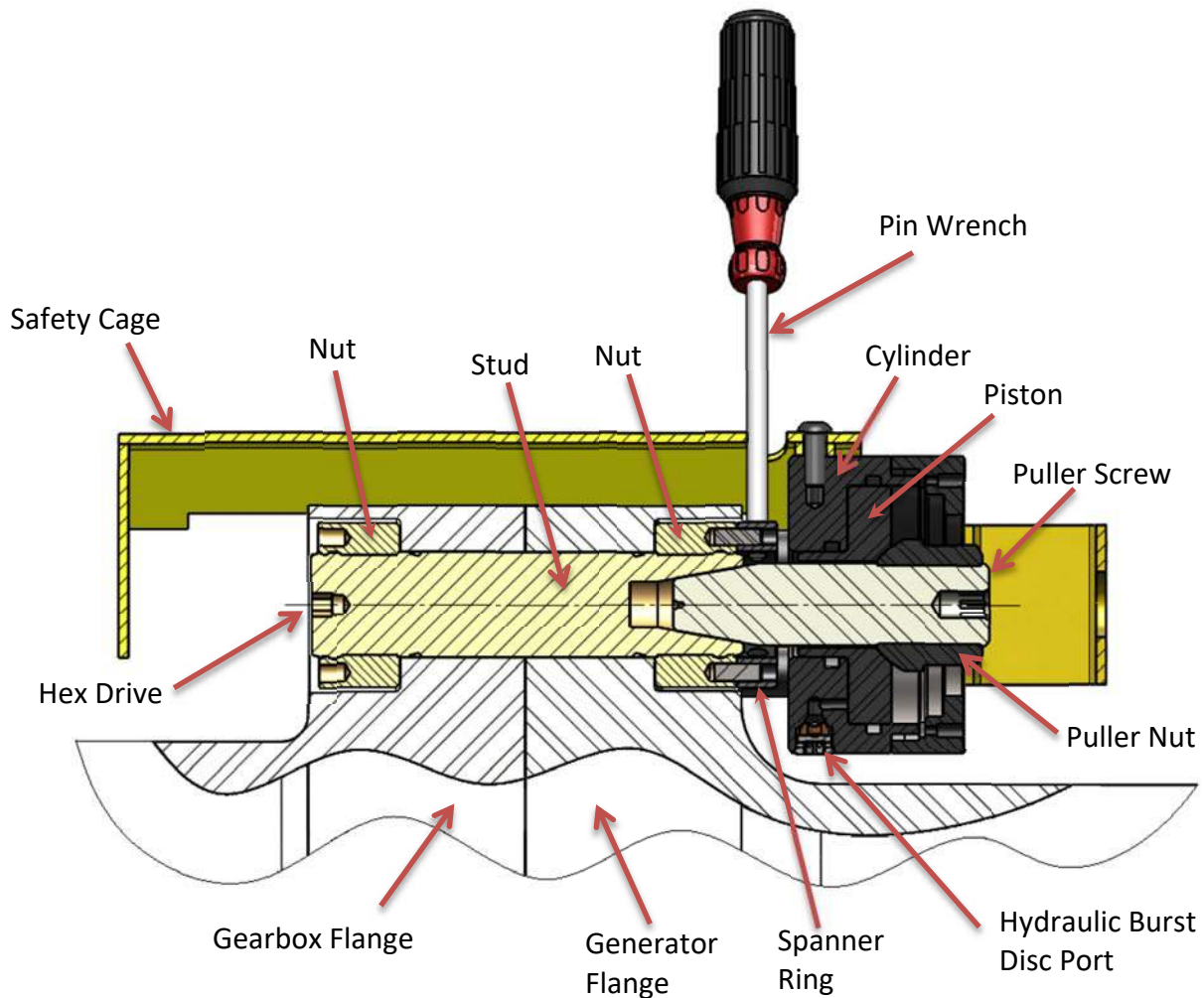

Figure 8E – Cross-section View of HT-3334 on 6FA Generator Flange

Assembly sequence is as follows:

1. Open the hydraulic return valve on the pump to allow hydraulic fluid to be pushed back from the tensioner into the pump reservoir. (This is automatic on the air-operated hydraulic pump)
2. Place the spanner ring on the puller-side cylindrical nut.



215 Clinton Road
New Hartford, NY 13413
Tel: +1 315 768 4855
Fax: +1 315 768 4941
Email: info@riverhawk.com

CUSTOMER'S INFORMATION BOX
CONTENTS ARE INDEPENDENT OF RIVERHAWK DOCUMENT CONTROL

GE DRAWING NUMBER	REV
373A4008	

Revision AB
Page 26 of 49

3. Apply a light coat of clean turbine oil or a spray lubricant to the puller screw. Do not use "Never Seize" on the conical threads.
4. Place and hold the tensioner over the end to be tightened.
5. Insert the puller screw through the tensioner into the tapered thread of the stud and tighten.
6. **Be sure not to cross-thread the assembly.**
7. Tighten the puller screw using Allen wrenches on the puller screw and the stud. **DO NOT** wrench on the Hex nut opposite the tensioner.
8. Install the puller nut until it seats snugly on the piston and then back-off 2 flats. This is particularly important for removal because the stud shortens during disassembly and the tensioner may then bind.
9. At this point the Tensioner Assembly **MUST BE FREE TO ROTATE**, the puller screw is tight in the stud and the puller nut has been backed-off the 2 flats.

Note: If the tool is not free to rotate it is most likely that the nuts must be repositioned so that the stud maybe shifted slightly to the tensioner side of the flange. This can be accomplished as follows:

1. Back off the puller nut and slightly loosen the puller screw.
2. Back off the Hex nut opposite the tensioner about 1 /2 turn.
3. Tighten the puller screw-side cylindrical nut to take up the slack
4. Retighten the puller screw per above and check for tool looseness

CAUTION

Do not over extend the stud. Over extension can cause the piston to lose its seal and leak oil.

CAUTION

Personal injury and equipment damage can occur if the puller screw is not securely engaged with the tapered threads of the stud. Proper engagement is achieved when the puller screw is tight in the stud and the tensioner assembly is free to turn.

8.3 Bleeding the Hydraulic System

WARNING

To avoid failure, ensure safety, and proper operation, the tensioner assembly must be installed on a stud in the flange before bleeding and pressurizing the tensioner. Do not use the tensioner at any pressure unless the tool is installed on a stud in a flange



215 Clinton Road
New Hartford, NY 13413
Tel: +1 315 768 4855
Fax: +1 315 768 4941
Email: info@riverhawk.com

CUSTOMER'S INFORMATION BOX
CONTENTS ARE INDEPENDENT OF RIVERHAWK DOCUMENT CONTROL

GE DRAWING NUMBER	REV
373A4008	

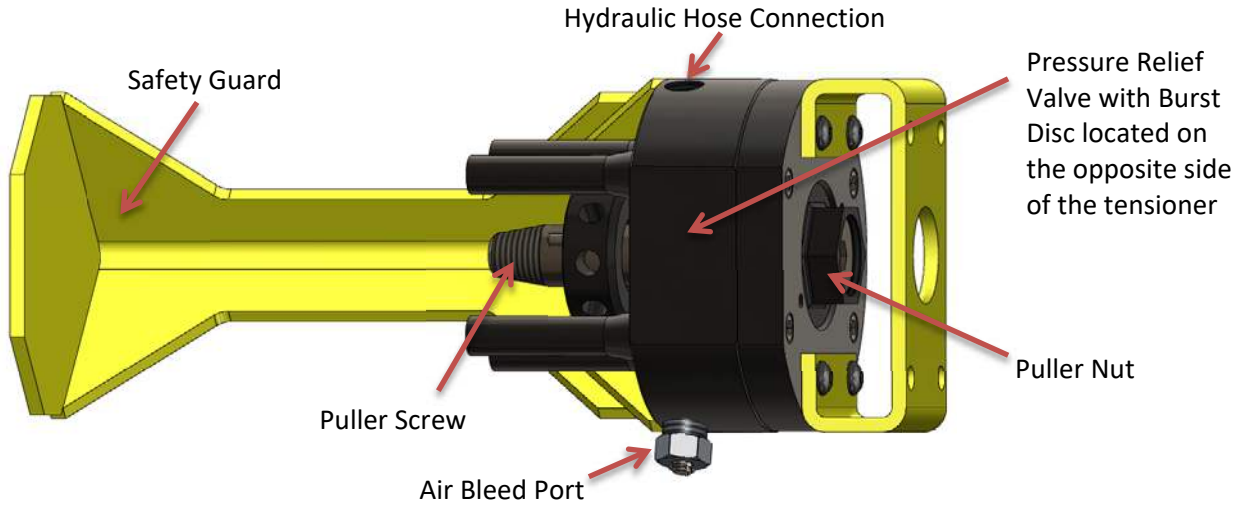

Picture 8F – Bleed Port Location on the HT-0406 Hydraulic Tensioner

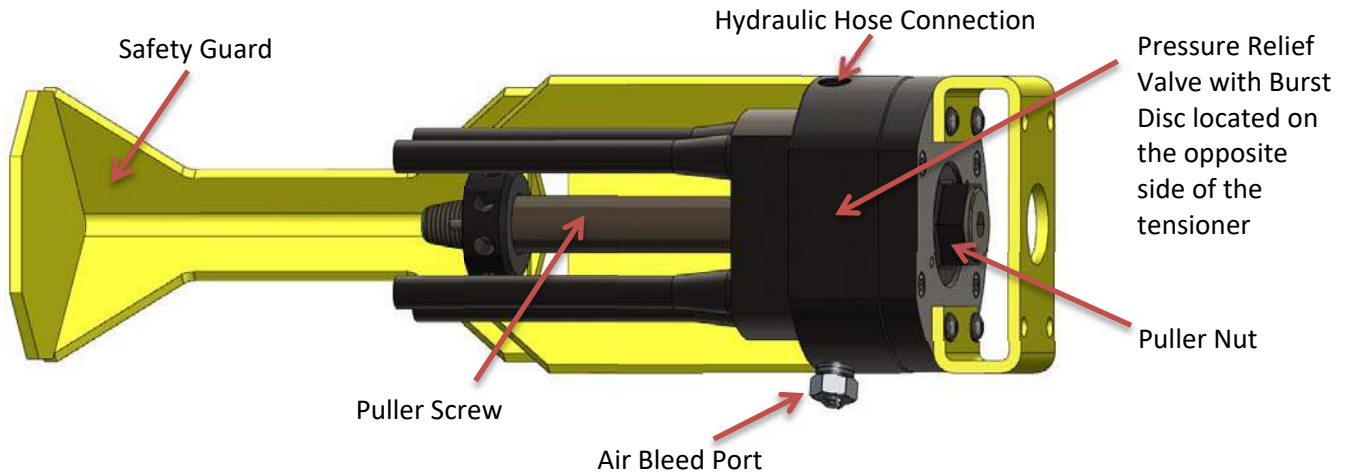

Picture 8G – Bleed Port Location on the HT-4856 Hydraulic Tensioner



215 Clinton Road
New Hartford, NY 13413
Tel: +1 315 768 4855
Fax: +1 315 768 4941
Email: info@riverhawk.com

CUSTOMER'S INFORMATION BOX
CONTENTS ARE INDEPENDENT OF RIVERHAWK DOCUMENT CONTROL

GE DRAWING NUMBER	REV
373A4008	

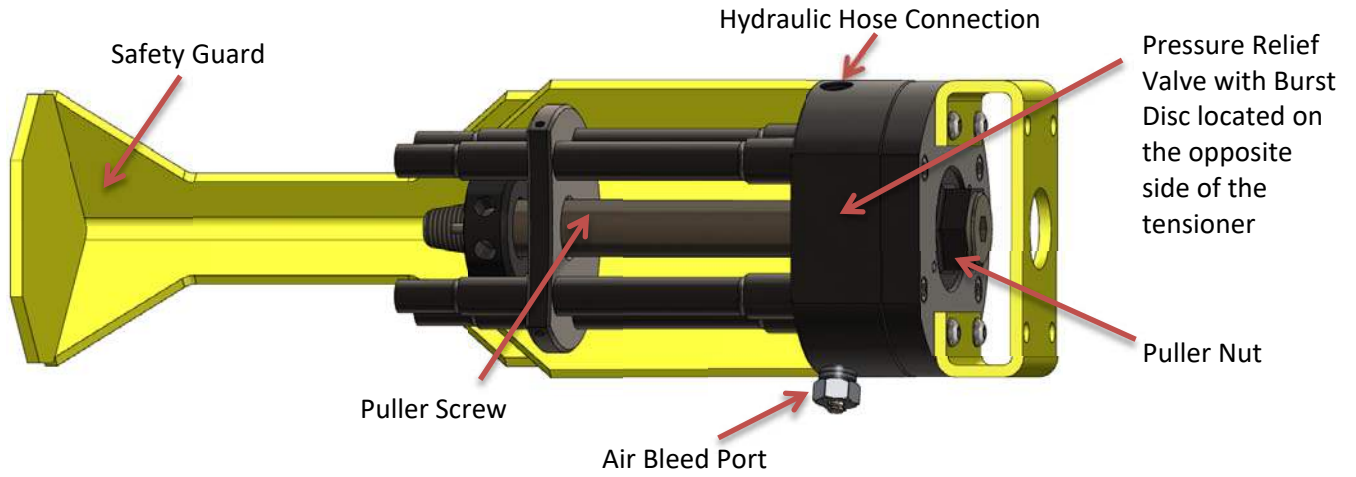

Picture 8H – Bleed Port Location on the HT-5618 Hydraulic Tensioner

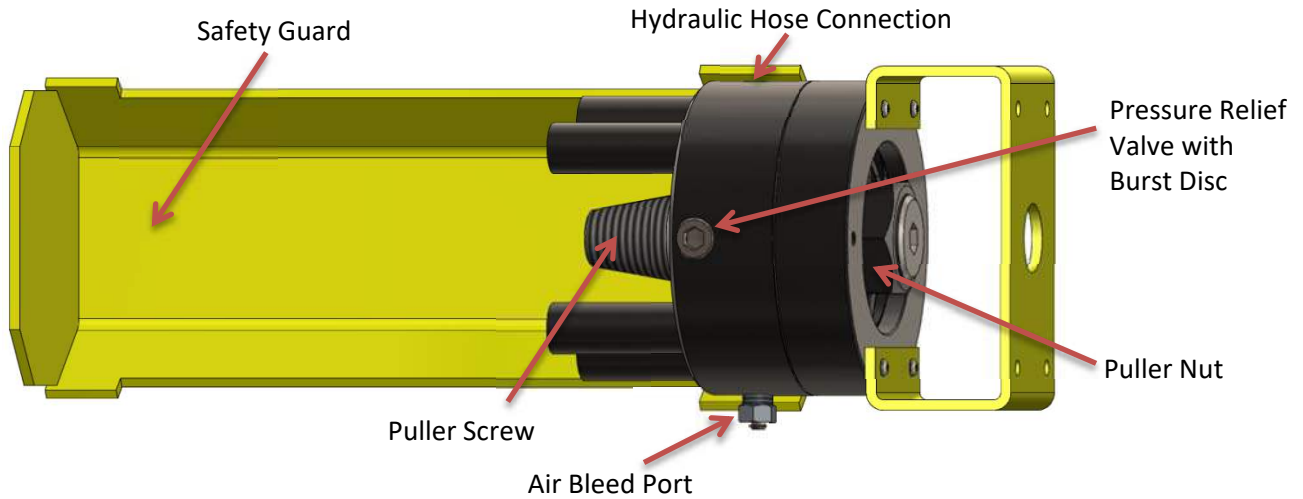

Picture 8J – Bleed Port Location on the HT-0716 Hydraulic Tensioner



215 Clinton Road
New Hartford, NY 13413
Tel: +1 315 768 4855
Fax: +1 315 768 4941
Email: info@riverhawk.com

CUSTOMER'S INFORMATION BOX
CONTENTS ARE INDEPENDENT OF RIVERHAWK DOCUMENT CONTROL

GE DRAWING NUMBER	REV
373A4008	

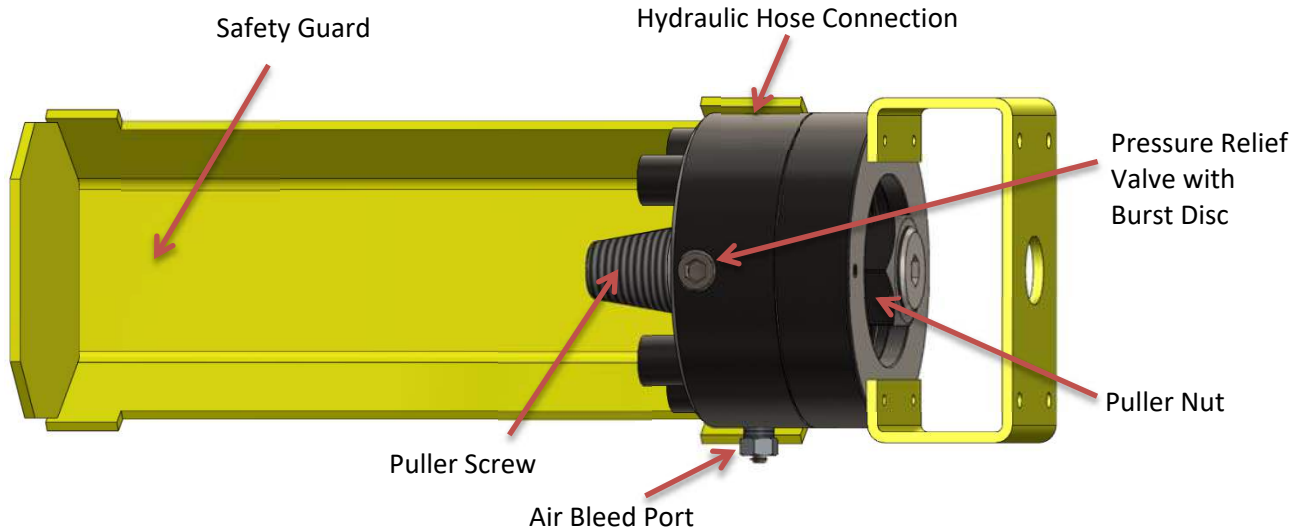

Picture 8K – Bleed Port Location on the HT-3334 Hydraulic Tensioner

The tensioner assembly has three ports, one for pressurizing, one for bleeding the system, and a third pressure relief port. To facilitate bleeding, start by first mounting the tensioner at either the 3 o'clock or 9 o'clock stud position. The bleed port must always be oriented in the uppermost position. In addition, make sure that the pump is always situated below the tensioner assembly.

The tensioner is equipped with a 5/8 in. [16 mm] hex coned stem bleeder fitting installed. With this fitting loosened, stroke the pump repeatedly until the stream of oil exiting the tool is free of air then retighten the fitting.

Note: The hose is stiff; use of this tooling can be simplified by temporarily installing the tensioner on one stud prior to final tightening of fittings. This will reduce the tendency for the fittings to loosen during use.

9.0 Stud Tensioning

The studs will be tensioned in two steps, at approximately 50% pressure and at final pressure. Follow the tensioning sequence for each flange joint as defined on the data sheets found at the end of this manual.



215 Clinton Road
 New Hartford, NY 13413
 Tel: +1 315 768 4855
 Fax: +1 315 768 4941
 Email: info@riverhawk.com

CUSTOMER'S INFORMATION BOX
 CONTENTS ARE INDEPENDENT OF RIVERHAWK DOCUMENT CONTROL

GE DRAWING NUMBER	REV
373A4008	

9.1 Tensioning at 50% pressure

After the tensioner is properly installed apply hydraulic pressure to the tool. Bring the pressure to the 50% level in accordance with the following table.

WARNING

The safety cage must be in place at all times. Keep hands out of designated areas at all times when the tensioner is pressurized otherwise personal injury can occur.

CAUTION

Before threading the puller screw into the stud, carefully check the cleanliness of both the stud's and the puller screw's conical threads. Apply a light coat of clean turbine oil or a spray lubricant to the puller screw. This procedure will ease assembly and assure positive mating of the threads before tightening. Do not use "Never Seize" on the conical threads.

CAUTION

Do not exceed the maximum pressure marked on the tensioner. Excessive pressure can damage the stud and puller screw.

CAUTION

Do not tighten the nut while the tool is coming up to pressure; wait until pressure is achieved before attempting to tighten the nut with the spanner ring. If the tool is not properly installed, the tool could jump off the stud while coming up to pressure.

<u>Flange Position</u>	<u>Stud Size</u>	<u>50% Pressure</u>	<u>50% Stretch</u>
Turbine to Coupling	1-1/8" [29 mm]	9000 psi [620 bar]	Do not measure Do not use
Coupling to Gearbox	1-1/8" [29 mm]	9000 psi [620 bar]	Do not measure Do not use
Gearbox to Generator	2" [51 mm]	8000 psi [550 bar]	Do not measure Do not use
Steam Turbine to Generator	2" [38 mm]	8000 psi [550 bar]	Do not measure Do not use

9.1.1 Tightening of 1-1/8" and 2" Nuts

Turn the cylindrical nut using the spanner ring and pin wrench until it bottoms on the flange.



215 Clinton Road
New Hartford, NY 13413
Tel: +1 315 768 4855
Fax: +1 315 768 4941
Email: info@riverhawk.com

CUSTOMER'S INFORMATION BOX
CONTENTS ARE INDEPENDENT OF RIVERHAWK DOCUMENT CONTROL

GE DRAWING NUMBER	REV
373A4008	

Revision AB
Page 31 of 49

9.2 Removing the Tensioner from an Installed Stud

Tensioner removal is to be accomplished as follows:

1. Release the tensioner pressure by opening the valve on the pump. Leave valve open. (This is automatic on the air-operated hydraulic pump)
2. Unscrew the puller screw using a wrench.
3. Tapping the wrench with a hammer may be necessary to loosen the puller screw.
4. Move the tool to the next stud/nut assembly to be tensioned, following the sequence/pattern as defined on the supplied data sheets.

9.3 Tensioning at Final Pressure

Repeat the pulling and tightening procedure stated above at full pressure. After all of the studs have been tensioned, measure the final stud length. The final pressure and required stretch values are listed in the following table.

WARNING

The safety cage must be in place at all times. Keep hands out of designated areas at all times when the tensioner is pressurized otherwise personal injury can occur.

CAUTION

Before threading the puller screw into the stud, carefully check the cleanliness of both the stud's and the puller screw's conical threads. Apply a light coat of clean turbine oil or a spray lubricant to the puller screw. This procedure will ease assembly and assure positive mating of the threads before tightening. Do not use "Never Seize" on the conical threads.

CAUTION

Do not exceed the maximum pressure marked on the tensioner. Excessive pressure can damage the stud and puller screw.

CAUTION

Do not tighten the nut while the tool is coming up to pressure; wait until pressure is achieved before attempting to tighten the nut with the spanner ring. If the tool is not properly installed, the tool could jump off the stud while coming up to pressure.



215 Clinton Road
New Hartford, NY 13413
Tel: +1 315 768 4855
Fax: +1 315 768 4941
Email: info@riverhawk.com

CUSTOMER'S INFORMATION BOX

CONTENTS ARE INDEPENDENT OF RIVERHAWK DOCUMENT CONTROL

GE DRAWING NUMBER	REV
373A4008	

Revision AB
Page 32 of 49

<u>Flange Position</u>	<u>Stud Size</u>	<u>Final Pressure</u>	<u>Final Stretch</u>
Turbine to Coupling	1-1/8" [29 mm]	18000 psi [1240 bar]	0.010" - 0.012" [0.25 mm - 0.31 mm]
Coupling to Gearbox	1-1/8" [29 mm]	18000 psi [1240 bar]	0.010" - 0.012" [0.25 mm - 0.31 mm]
Gearbox to Generator	2" [51 mm]	16000 psi [1100 bar]	0.010" - 0.012" [0.25 mm - 0.31 mm]
Steam Turbine to Generator	2" [51 mm]	16000 psi [1100 bar]	0.010" - 0.012" [0.25 mm - 0.31 mm]

Excessive stretch variations or low stretch values can be corrected by uninstalling all or selected studs to the pressure values stated in the above table. Have final stretch values approved by the supervisor responsible for the installation.

9.3.1 Tightening of 1-1/8" Nuts

Turn the cylindrical nut using the spanner ring and pin wrench until it bottoms on the flange. Then apply torque to turn the nut an additional 10 deg. This will aid in achieving the desired stretch.

9.3.2 Tightening of 2" Nuts

Turn the cylindrical nut using the spanner ring and pin wrench until it bottoms on the flange.

10.0 Thread Locking

Once pulling and tensioning is completed all stud nuts must be locked in position. Two methods of thread locking may be encountered in the field. Early version hardware uses a liquid thread locking compound while the current configuration employs a mechanical locking device. Each method is described in detail in Sections 10.1 and 10.2.



215 Clinton Road
New Hartford, NY 13413
Tel: +1 315 768 4855
Fax: +1 315 768 4941
Email: info@riverhawk.com

CUSTOMER'S INFORMATION BOX
CONTENTS ARE INDEPENDENT OF RIVERHAWK DOCUMENT CONTROL

GE DRAWING NUMBER	REV
373A4008	

10.1 Thread Locking Using a Mechanical Locknut



Picture 10A - Riverhawk Locknut

Mechanical lock nuts have two set screws located in the top face, see picture. Before threading the nut onto the stud check to be certain the set screws are free to turn. Once the nut is seated torque the set screws to the values specified in the following table. When seated and torqued to the values specified the load created by the set screw displaces the thread of the nut in the area of the web creating the desired locking action.

<u>Stud Size</u>	<u>Set Screw Size</u>	<u>Torque</u>
1-1/8" [29 mm]	#10-32 UN	30 in·lbs - 36 in·lbs [3.4 N·m - 4.1 N·m]
2" [51 mm]	1/4-28 UN	65 in·lbs - 87 in·lbs [22.6 N·m - 28.2 N·m]



215 Clinton Road
 New Hartford, NY 13413
 Tel: +1 315 768 4855
 Fax: +1 315 768 4941
 Email: info@riverhawk.com

CUSTOMER'S INFORMATION BOX
 CONTENTS ARE INDEPENDENT OF RIVERHAWK DOCUMENT CONTROL

GE DRAWING NUMBER	REV
373A4008	

10.2 Thread Locking Using a Liquid Locking Compound

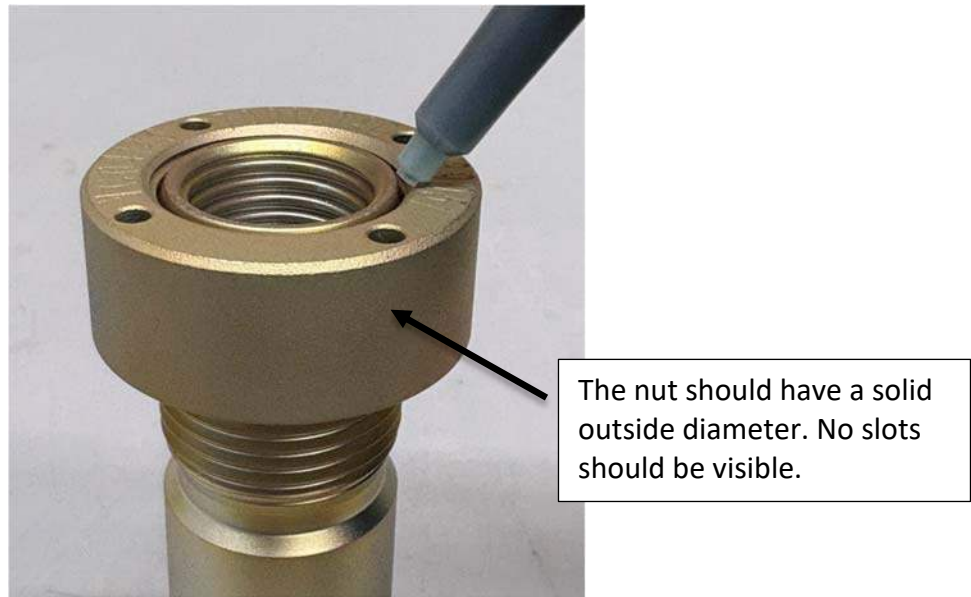

Picture 10B - Riverhawk nut without Mechanical Locking

These nuts have no visible locking feature. Contact Riverhawk Company if you have any of these older style nuts

11.0 Stud and Nut Removal

Sections 11.1 and 11.2 respectively describe the procedures to be followed in removing nuts that have been locked with the mechanical locking feature and the other locking method of using liquid locking compound.



215 Clinton Road
New Hartford, NY 13413
Tel: +1 315 768 4855
Fax: +1 315 768 4941
Email: info@riverhawk.com

CUSTOMER'S INFORMATION BOX

CONTENTS ARE INDEPENDENT OF RIVERHAWK DOCUMENT CONTROL

GE DRAWING NUMBER	REV
373A4008	

Revision AB
Page 35 of 49

11.1 Removal of Assemblies with Mechanical Locknuts



Picture 11A - Riverhawk Locknut

For those assemblies which have been locked using mechanical lock nuts, removal is accomplished as follows:

1. Using a wire brush, GT-4354, and shop air clean the internal tapered thread of the stud to remove any debris/deposits which may have accumulated during service. (see section 5.2.2)

With an Allen-wrench loosen the two locking set screws but do not remove from nut.



Picture 11B - Loosening of a nut's set screws

2. Install the appropriate tensioner to the stud as described in Section 8.0.



215 Clinton Road
New Hartford, NY 13413
Tel: +1 315 768 4855
Fax: +1 315 768 4941
Email: info@riverhawk.com

CUSTOMER'S INFORMATION BOX
CONTENTS ARE INDEPENDENT OF RIVERHAWK DOCUMENT CONTROL

GE DRAWING NUMBER	REV
373A4008	

Revision AB
Page 36 of 49

3. Apply the appropriate hydraulic pressure per the table of Section 11.1 and using the spanner ring and spanner wrenches loosen the nut, then release the pressure and remove the tensioner.

11.2 Removal of Assemblies with Liquid Locking Compound

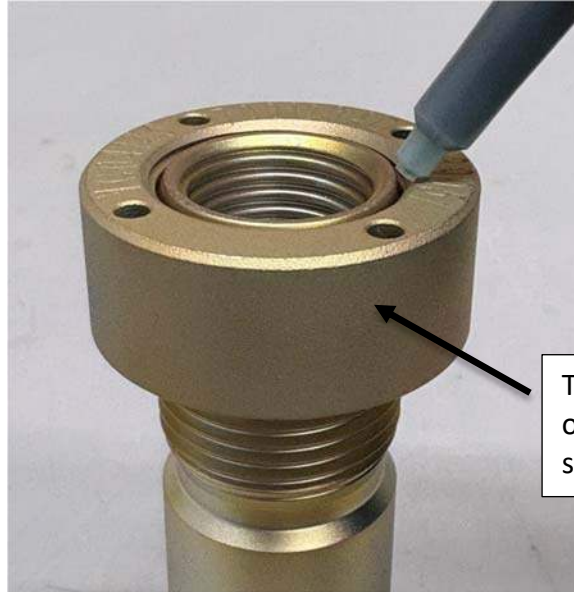

Picture 11C - Riverhawk nut without Mechanical Locking

For those assemblies which have been locked with the liquid locking compound, removal is accomplished as follows:

- Using a wire brush and shop air clean the internal tapered thread of the stud to remove any debris/deposits that may have accumulated during service. (See section 5.2.2)
- Install the appropriate tensioner to the stud as described in Section 8.0.
- Apply hydraulic pressure per the following table and without using unreasonable force attempt to loosen the nut using the spanner ring and spanner wrench.

<u>Flange Position</u>	<u>Stud Size</u>	<u>Final Pressure</u>
Turbine to Coupling	1-1/8" [29 mm]	18000 psi [1250 bar]
Coupling to Gearbox	1-1/8" [29 mm]	18000 psi [1250 bar]



215 Clinton Road
New Hartford, NY 13413
Tel: +1 315 768 4855
Fax: +1 315 768 4941
Email: info@riverhawk.com

CUSTOMER'S INFORMATION BOX
CONTENTS ARE INDEPENDENT OF RIVERHAWK DOCUMENT CONTROL

GE DRAWING NUMBER	REV
373A4008	

<u>Flange Position</u>	<u>Stud Size</u>	<u>Final Pressure</u>
Gearbox to Generator	2" [51 mm]	18000 psi [1250 bar]
Steam Turbine to Generator	2" [51 mm]	18000 psi [1250 bar]

If the nut cannot be loosened, release the pressure and repeat the procedure.

- Ordinarily two or three attempts are sufficient to break the bond.
- Should the nut refuse to loosen after three attempts the application of heat will be required.

CAUTION

Do not exceed the maximum pressure marked on the tensioner. Excessive pressure can damage the stud and puller screw.

WARNING:

FIRE HAZARD; DO NOT heat when the tensioner is in place. Personal injury or equipment damage may occur. Use of an Oxy-Acetylene torch is not recommended

Apply a smear of 550/650-deg F tempil stick to the side of the nut opposite the application of heat and heat the nut using a propane torch. Continue to apply heat until the tempil smear indicates that the nut has reached 550/650 deg F. **Never overheat to a cherry red condition.** Remove the source of heat and as quickly as possible reinstall the appropriate tensioner, apply the appropriate pressure per the following table and loosen the nut. Then release the pressure and remove the tensioner.

12.0 Storage Instructions

Follow these directions to properly store your hydraulic tensioner and hydraulic pump kit for long term storage and shipment.

If any damage is observed, contact the Riverhawk Company to schedule a maintenance inspection.

12.1 Hydraulic Pump Kit Storage

Refer to the Hydraulic Pump Kit Instruction Manual, IM-293 (GE VENDOC 373A4058). The latest revision may be obtained by contacting Riverhawk Company or thru www.riverhawk.com.



215 Clinton Road
 New Hartford, NY 13413
 Tel: +1 315 768 4855
 Fax: +1 315 768 4941
 Email: info@riverhawk.com

CUSTOMER'S INFORMATION BOX
 CONTENTS ARE INDEPENDENT OF RIVERHAWK DOCUMENT CONTROL

GE DRAWING NUMBER	REV
373A4008	

12.2 Hydraulic Tensioner Storage

Check the tensioner for any damage.

1. Clean puller screw and check for any debris and dents.
2. Puller screw should be free to rotate and move back and forth.
3. Seam between the cylinder and its end cap is closed tightly.
4. Inspect tensioner guard for any signs of damage. Bent guards should be replaced. Missing rubber pads must be replaced.

If any damage is observed, contact the Riverhawk Company to schedule a maintenance inspection.

Place protective red plastic cap into the hydraulic port.

Coat the hydraulic tensioner with a light coat of oil and place the tensioner into the original shipping container.

12.3 Store shipping container

Secure the hydraulic pump and hydraulic tensioner into the original shipping containers using the supplied wood braces.

Seal the original shipping container and store under shelter and protected from moisture, sand, and grit.

13.0 Frequently Asked Questions

This section contains some frequently asked questions and problems. If the steps listed here do not solve your problem, contact the Riverhawk Company thru our website, email, or phone call.

Q: Can I rent a hydraulic tensioner kit?

A: Yes, Riverhawk has rental tensioner kits available for most of our hydraulic tensioners.



215 Clinton Road
New Hartford, NY 13413
Tel: +1 315 768 4855
Fax: +1 315 768 4941
Email: info@riverhawk.com

CUSTOMER'S INFORMATION BOX
CONTENTS ARE INDEPENDENT OF RIVERHAWK DOCUMENT CONTROL

GE DRAWING NUMBER	REV
373A4008	

Q: A tensioner has pulled itself out of the stud's conical threads. Can I continue using a tensioner on this stud?

A: No. Both the tensioner and the stud may have been damaged and must be removed from the work area. If the stud is tensioned, a Nut Buster repair kit, from Riverhawk, must be used to remove the damaged stud by drilling out the nut. Leaving a damaged stud in place will lead to a safety hazard on future outages.

Riverhawk can supply a replacement stud and nut based on the initial weight certification supplied with the hardware set (see section 4.2). The damaged tensioner should also be returned to Riverhawk for inspection and repair.

If a stud must be left in place, paint the damaged stud with a generous amount of indelible, bright-colored paint. Notify the appropriate GE Safety and Service personnel. Note the location of the damaged stud in the services notes for the machine.

Q: The hydraulic tensioner has been taken up to its final pressure. The final stretch length is short of the final stretch target. What is the next step?

A: Do not increase the hydraulic pressure. Check if the hydraulic pump is set to the right pressure. Install the tensioner and re-pressurize the tensioner to the final pressure then recheck the stretch measurement. If the stretch value is still short, remove the stud from the hole and re-measure the stud's initial length then try to install the stud again.

Q: The hydraulic tensioner has been taken up to its final pressure. The final stretch length is larger than the final stretch target. What is the next step?

A: Remove the stud from the bolt hole. Check if the hydraulic pump is set to the right pressure. Re-measure the stud's initial length then try to install the stud again.

Q: Is there an easier way to support or move the tensioner around the coupling shaft?

A: Use two straps. One around the coupling shaft and the other attach to an overhead support. Straps must be slack while installing the tensioner on a stud and while tensioning.



215 Clinton Road
New Hartford, NY 13413
Tel: +1 315 768 4855
Fax: +1 315 768 4941
Email: info@riverhawk.com

CUSTOMER'S INFORMATION BOX
CONTENTS ARE INDEPENDENT OF RIVERHAWK DOCUMENT CONTROL

GE DRAWING NUMBER	REV
373A4008	

Revision AB
Page 40 of 49

- Q:** The tensioner is at its final pressure, but the nut cannot be loosened.
- A:** If the nuts cannot be loosened at the final pressure, continually increasing the pressure will not help and can be dangerous and in some cases make it harder to remove the nut. Check the nut to see if its set screws have been loosened. Check for and remove any corrosion around the nut's threads.
- Q:** How do I clean the conical threads on a stud?
- A:** The conical threads are best cleaned using a spiral wound brass brush in a drill as described in section 5.2.2
- Q:** During the initial steps of removing a tensioned stud, the stick-out length is found to be wrong.
- A:** Do not proceed. Contact Riverhawk for assistance. With the wrong stick-out length, the hydraulic tensioner has a limited stroke and may not work properly and can be damaged.
- Q:** The hydraulic pump appears to be leaking.
- A:** Check the hose connection to the hydraulic pump. If the 1/4" high pressure fitting is not assembled correctly as shown in Appendix B1, it may look like the pump is leaking. If the problem continues, it may be necessary to return the pump kit to the Riverhawk factory. Contact Riverhawk for guidance.
- Q:** The hydraulic hose has a collar on it that can't be moved by hand
- A:** The hydraulic fitting is shown in Appendix B1. The collar is sometimes held in place with a thread locking compound. This prevents the collar from moving too easily. It may be necessary to adjust this collar with a set of vise-grip pliers. Be careful to not strip the threads off the tube or hose end.



215 Clinton Road
New Hartford, NY 13413
Tel: +1 315 768 4855
Fax: +1 315 768 4941
Email: info@riverhawk.com

CUSTOMER'S INFORMATION BOX
CONTENTS ARE INDEPENDENT OF RIVERHAWK DOCUMENT CONTROL

GE DRAWING NUMBER	REV
373A4008	

14.0 Revision History

Revision Letter	Effective Date	Description
AB	May 14, 2026	Updated section 10 and 11
AA	Mar 13, 2026	Updated Figure 2E
Y	Jun 10, 2022	Revised figures 6A, 6B, 6C and 6D in section 6; Inserted Appendix B1
W	May 19, 2022	Updated EC Declaration of Conformity; Added UKCA Declaration of Conformity
V	Jan 16, 2015	Updated sections 1.0, 4.3 and Appendix A4.
U	Jun 12, 2014	Added EC Declaration of Conformity
T	Nov 28, 2012	Reformatted, general update to warnings and cautions; Added IM-293 to sections 7.1.2 and 12.1; Removed 356A3954P003; Moved and Renumbered figures and pictures
S	Sept 14, 2011	Revised sections 7.1.1 and 7.2; Revised figure 3; Removed figure 4.
R	Jun 16, 2011	Added Steam Turbine to 6FA Generator to title page; Added HF-0748 to section 2.0; Added HT-3334 to section 4.5; Added Steam Turbine to Generator 2" section to tables in sections 9.1 and 9.3; Revised Figure 3
Q	Jan 31, 2011	Added Steam Turbine to 9A4 Elin Generator to title page; Added Steam turbine to generator 2-3/4" section to tables in sections 9.1 and 9.3
P	Jun 10, 2009	Added turbine oil and removed "Never Seize" from sections 1.0, 3.0, 8.1, 8.2, and 9.0
N	Mar 25, 2009	Added sections 3.0 and 13.0
M	Jul 18, 2006	Revised generator stretch value



215 Clinton Road
 New Hartford, NY 13413
 Tel: +1 315 768 4855
 Fax: +1 315 768 4941
 Email: info@riverhawk.com

CUSTOMER'S INFORMATION BOX
 CONTENTS ARE INDEPENDENT OF RIVERHAWK DOCUMENT CONTROL

GE DRAWING NUMBER	REV
373A4008	

Instruction Manual IM-101

Revision Letter	Effective Date	Description
L		
K	Dec 10, 2004	Moved caution notes
J	Jun 15, 2004	Corrected stretch value error
H	Dec 08, 2003	Added GE title block and part number
G	Sept 22, 2003	Revised record sheet to reflect 27 studs
F	Jun 19, 2000	Page 2 para 2.0, Page 4 para 4.0 & 5.3, Page 8 para 7.2, Page 9 para 9.1
E	Jan 10, 2000	Page 1
D	Jul 20, 1999	
C	Apr 01, 1999	
B	May 09, 1997	
A	Feb 12, 1997	
-	Sept 03, 1996	Released



215 Clinton Road
 New Hartford, NY 13413
 Tel: +1 315 768 4855
 Fax: +1 315 768 4941
 Email: info@riverhawk.com

CUSTOMER'S INFORMATION BOX
 CONTENTS ARE INDEPENDENT OF RIVERHAWK DOCUMENT CONTROL

GE DRAWING NUMBER	REV
373A4008	

Appendix A1

EC Declaration of Conformity

Manufacturer: Riverhawk Company
Address: 215 Clinton Road
New Hartford, NY 13413, USA

The hydraulic pump and bolt tensioning tool described in this manual are used for installing and applying tension to large bolts that are specifically designed by Riverhawk Company to be tensioned hydraulically.

All applicable sections of European Directive 2006/42/EC for machinery have been applied and fulfilled in the design and manufacture of the hydraulic pump and bolt tensioning tool described in this manual. Reference also ISO 12100:2010, ISO 4413:2010, and ISO 4414:2010.

Furthermore, this equipment has been manufactured under the Riverhawk quality system per EN ISO 9001:2015

Consult the Declaration of Conformance included with the shipment of this equipment that identifies the authorized Riverhawk representative, applicable serial numbers, and appropriate signature.



215 Clinton Road
New Hartford, NY 13413
Tel: +1 315 768 4855
Fax: +1 315 768 4941
Email: info@riverhawk.com

CUSTOMER'S INFORMATION BOX

CONTENTS ARE INDEPENDENT OF RIVERHAWK DOCUMENT CONTROL

GE DRAWING NUMBER	REV
373A4008	

Revision AB
Page 44 of 49

Appendix A2

UKCA Declaration of Conformity

Manufacturer: Riverhawk Company
Address: 215 Clinton Road
New Hartford, NY 13413, USA

The hydraulic pump and bolt tensioning tool described in this manual are used for installing and applying tension to large bolts that are specifically designed by Riverhawk Company to be tensioned hydraulically.

All applicable sections of Supply of Machinery (Safety) 2008 have been applied and fulfilled in the design and manufacture of the hydraulic pump and bolt tensioning tool described in this manual. Reference also ISO 12100:2010, ISO 4413:2010, and ISO 4414:2010.

Furthermore, this equipment has been manufactured under the Riverhawk quality system per EN ISO 9001:2015

Consult the Declaration of Conformance included with the shipment of this equipment that identifies the authorized Riverhawk representative, applicable serial numbers, and appropriate signature.



215 Clinton Road
New Hartford, NY 13413
Tel: +1 315 768 4855
Fax: +1 315 768 4941
Email: info@riverhawk.com

CUSTOMER'S INFORMATION BOX

CONTENTS ARE INDEPENDENT OF RIVERHAWK DOCUMENT CONTROL

GE DRAWING NUMBER	REV
373A4008	

Revision AB
Page 45 of 49

Appendix B1 - Hydraulic Fittings

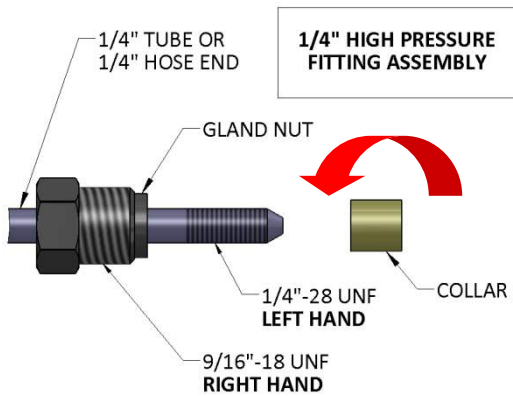

Illustration 1

Riverhawk tensioners use a 1/4" High Pressure port to connect its hydraulic hoses. The hose connector is made from a three piece assembly: a gland nut, a collar, and a 1/4" tube or 1/4" hose end. (See Illustration 1)

To assembly the fitting, slide the gland nut over the 1/4" tube or 1/4" hose end. Turn the collar counter-clockwise (**left hand** thread) on to the tube or hose end as shown in Illustration 1.

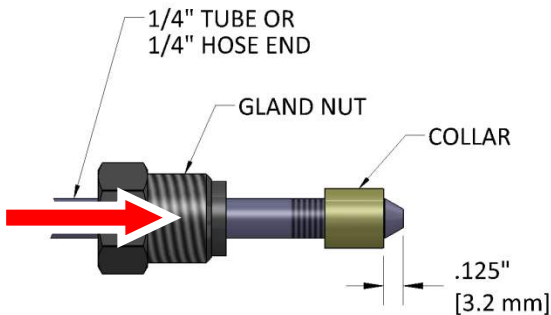

Illustration 2

The collar should be placed .125" (3.2 mm) from the tip of the cone. (See Illustration 2) It may be necessary to adjust this collar with a set of vise-grip pliers. Be careful to not strip the threads off the tube or hose end.

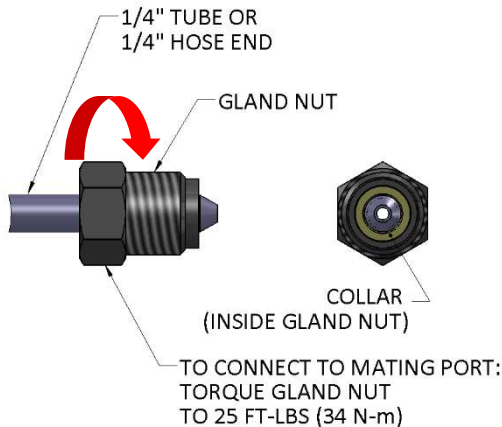

Illustration 3

Slide the gland nut down over the collar. (See Illustration 3) Insert the 1/4" tube or 1/4" hose end into tensioner or hydraulic pump. While firmly holding the tube or hose end to stop it from rotating, turn the gland nut clockwise (**right hand** thread) and torque the gland nut to 25 FT-LBS (34 N-m).

Tips:

- Make sure all parts are clean and free from debris.
- Protect the cone on the end of the 1/4" tube or 1/4" hose end from scratches as this is the sealing surface.
- Replace red plastic caps when finished to protect the threads and cone.



215 Clinton Road
 New Hartford, NY 13413
 Tel: +1 315 768 4855
 Fax: +1 315 768 4941
 Email: info@riverhawk.com

CUSTOMER'S INFORMATION BOX
 CONTENTS ARE INDEPENDENT OF RIVERHAWK DOCUMENT CONTROL

GE DRAWING NUMBER	REV
373A4008	

Appendix C1

STRETCH RECORD SHEET FOR
THE GAS TURBINE TO LOAD COUPLING

TURBINE NUMBER:

DATE:

TECHNICIAN:

SUPERVISOR:

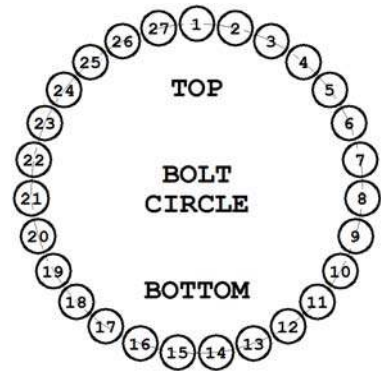

Hole Number	Starting Length	Final Length	Final Stretch
1			
14			
2			
15			
3			
16			
4			
17			
5			
18			
6			
19			
7			
20			
8			
21			
9			
22			
10			
23			
11			
24			
12			
25			
13			
26			
27			

CUSTOMER'S INFORMATION BOX

CONTENTS ARE INDEPENDENT OF RIVERHAWK DOCUMENT CONTROL

GE DRAWING NUMBER	REV
373A4008	



215 Clinton Road
New Hartford, NY 13413
Tel: +1 315 768 4855
Fax: +1 315 768 4941
Email: info@riverhawk.com

Appendix C2

STRETCH RECORD SHEET FOR
THE LOAD COUPLING TO GEARBOX

TURBINE NUMBER:

DATE:

TECHNICIAN:

SUPERVISOR:

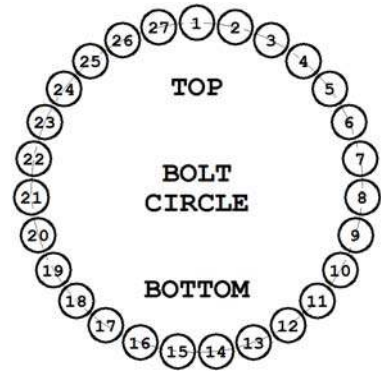

Hole Number	Starting Length	Final Length	Final Stretch
1			
14			
2			
15			
3			
16			
4			
17			
5			
18			
6			
19			
7			
20			
8			
21			
9			
22			
10			
23			
11			
24			
12			
25			
13			
26			
27			

CUSTOMER'S INFORMATION BOX

CONTENTS ARE INDEPENDENT OF RIVERHAWK DOCUMENT CONTROL

GE DRAWING NUMBER	REV
373A4008	



215 Clinton Road
New Hartford, NY 13413
Tel: +1 315 768 4855
Fax: +1 315 768 4941
Email: info@riverhawk.com

Appendix C3

STRETCH RECORD SHEET FOR
THE GEARBOX TO GENERATOR

TURBINE NUMBER:

DATE:

TECHNICIAN:

SUPERVISOR:

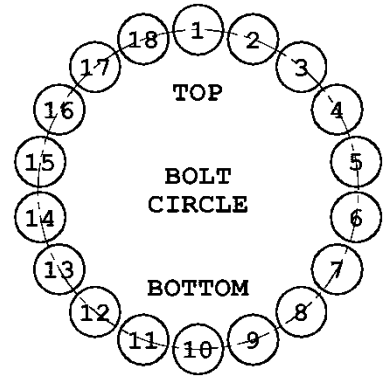

HOLE NUMBER	STARTING LENGTH	FINAL LENGTH	FINAL STRETCH
1			
10			
2			
11			
3			
12			
4			
13			
5			
14			
6			
15			
7			
16			
8			
17			
9			
18			

CUSTOMER'S INFORMATION BOX

CONTENTS ARE INDEPENDENT OF RIVERHAWK DOCUMENT CONTROL

GE DRAWING NUMBER	REV
373A4008	



215 Clinton Road
New Hartford, NY 13413
Tel: +1 315 768 4855
Fax: +1 315 768 4941
Email: info@riverhawk.com