



INSTRUCTION MANUAL IM-382
For Gas Turbine
Tensioned Studs and Nuts

Applicable Bolting Connections

Frame 9FA Gas Turbine to 324 Generator
 Frame 9FA Gas Turbine to Load Coupling
 Load Coupling to 324 Generator
 Steam Turbine to 324 Generator

Applicable GE Ordering Sheet Part Numbers

358A7202G0001	358A7202P044	112T8262G0001
358A7202P0019	358A7202P045	
358A7202P037	358A7202P046	808L5279G0001
358A7202P040	358A7202P047	
358A7202P041	358A7202P048	
358A7202P0043		

CUSTOMER'S INFORMATION BOX

CONTENTS ARE INDEPENDENT OF RIVERHAWK DOCUMENT CONTROL

GE Power & Water		GENERAL ELECTRIC COMPANY	
<u>VENDOR SUPPLIED</u>			
GE NOT TO REVISE. GE REVISION LEVEL IS SHOWN ON THIS APPLIQUE. THIS DOCUMENT IS FILED UNDER THE GE DRAWING NUMBER.			
THIS DOCUMENT SHALL BE REVISED IN ITS ENTIRETY. ALL SHEETS OF THIS DOCUMENT ARE THE SAME REVISION LEVEL AS INDICATED IN THIS VENDOR SUPPLIED DRAWING APPLIQUE.			
MLI:		_____ OF _____	
GE SIGNATURES	DATE	GE DRAWING NUMBER	REV
CHECKED:		373A4094	
ISSUED:			

The Riverhawk Company reserves the right to update this document without dissemination or notice. The latest revision may be obtained by contacting Riverhawk Company or thru www.riverhawk.com.



Repairs – Rentals
 Field Service

215 Clinton Road
 New Hartford, NY 13413
 Tel: +1 315 768 4855
 Fax: +1 315 768 4941
 Email: info@riverhawk.com

Table of Contents

1.0 Cautions and Safety Warnings..... 3

2.0 Scope..... 5

3.0 Quick Checklist 7

4.0 General Preparations 10

5.0 Hardware Set Preparations 12

6.0 Stud and Nut Assembly 14

7.0 Hydraulic Tensioner Equipment Assembly 17

8.0 Assembly of Tensioner on a Stud 18

9.0 Stud Tensioning..... 23

10.0 Thread Locking and Windage Plug Installation..... 26

11.0 Stud and Nut Removal..... 27

12.0 Storage Instructions 28

13.0 Frequently Asked Questions 29

14.0 Revision History..... 32

Appendix A1 – EC Declaration of Conformity..... 33

Appendix A2 – UKCA Declaration of Conformity..... 34

Appendix B1 - Hydraulic Fittings 35

Appendix C1 - Record Sheet 18 Colt Circle..... 36

Appendix C2 - Record Sheet 16 Colt Circle..... 37

CUSTOMER'S INFORMATION BOX

CONTENTS ARE INDEPENDENT OF RIVERHAWK DOCUMENT CONTROL



215 Clinton Road
New Hartford, NY 13413
Tel: +1 315 768 4855
Fax: +1 315 768 4941
Email: info@riverhawk.com

GE DRAWING NUMBER	REV
373A4094	

1.0 Cautions and Safety Warnings

WARNING

Improper tool use and the failure to follow the correct procedures are the primary root causes of tool failures and personal injuries. A lack of training or experience can lead to incorrect hardware installation or incorrect tool use. Only trained operators with careful, deliberate actions should use hydraulic tensioners. Contact Riverhawk Company with any training needs.

WARNING

Risk of high pressure hydraulic fluid injection. Riverhawk tools operate under high pressure. Thoroughly inspect all hoses and connections for damage or leaks prior to using this equipment.

CAUTION

Personal injury and equipment damage can occur if the proper health and safety codes and procedures are not followed. Contact the site's health and safety office to determine all applicable safety rules and regulations.

WARNING

The proper personal protective equipment must be worn at all times. Riverhawk recommends at a minimum, safety glasses, long sleeve shirt, hard hat, heavy work gloves, and steel toe shoes.

CAUTION

It is especially important to check the condition of the conical thread used to tension the stud. Thread damage from previous abuse can lead to failure of the stud or tensioning equipment

CAUTION

Riverhawk recommends that the tensioner should be returned to Riverhawk for periodic inspections. Replacement of obsolete tensioners is recommended. Functional upgrades are also recommended. The Riverhawk Service Returns Coordinator should be notified 3-6 months prior to a planned outage to schedule an inspection service.

WARNING

A damaged burst disc must be replaced with a with a burst disc of the same design and pressure rating. Do not substitute a damaged burst disc with a different disc type, a different pressure rating, or a foreign object.

CUSTOMER'S INFORMATION BOX

CONTENTS ARE INDEPENDENT OF RIVERHAWK DOCUMENT CONTROL



215 Clinton Road
New Hartford, NY 13413
Tel: +1 315 768 4855
Fax: +1 315 768 4941
Email: info@riverhawk.com

GE DRAWING NUMBER	REV
373A4094	

Revision F
Page 3 of 37

WARNING

To avoid failure, ensure safety, and proper operation, the tensioner assembly must be installed on a stud in the flange before pressurizing the tensioner. Do not use the tensioner at any pressure unless the tool is installed on a stud in a flange.

CAUTION

Do not over extend the tensioner. Over extension may cause the piston to lose its seal and leak oil.

CAUTION

Personal injury and equipment damage can occur if the puller screw is not securely engaged with the tapered threads of the stud. Proper engagement is achieved when the puller screw is tight in the stud and the tensioner assembly is free to turn.

WARNING

The safety interlock guard must be in place at all times. When the tensioner is pressurized hands must be kept out of designated areas to avoid any potential for personal injury.

CAUTION

Before threading the puller screw into the stud, carefully check the cleanliness of both the stud's and the puller screw's conical threads. Apply a light coat of clean turbine oil or a spray lubricant to the puller screw. This procedure will ease assembly and assure positive mating of the threads before tightening. Do not use "Never Seize" on the conical threads.

CAUTION

Do not tighten the nut while the tool is coming up to pressure; wait until pressure is achieved before attempting to tighten the nut with the spanner ring. If the tool is not properly installed, the tool could jump off the stud while coming up to pressure.

CAUTION

Do not exceed the maximum pressure marked on the tensioner. Excessive pressure can damage the stud and puller screw.

WARNING

FIRE HAZARD: DO NOT heat when puller assembly is in place. Personal injury or equipment damage may occur. Use of an Oxy-Acetylene torch is not recommended

CUSTOMER'S INFORMATION BOX

CONTENTS ARE INDEPENDENT OF RIVERHAWK DOCUMENT CONTROL



215 Clinton Road
New Hartford, NY 13413
Tel: +1 315 768 4855
Fax: +1 315 768 4941
Email: info@riverhawk.com

GE DRAWING NUMBER	REV
373A4094	

2.0 Scope

This document describes the procedure to be used to install the stud and nut sets supplied by the Riverhawk Company in the flanges at the Load Coupling/Generator and Steam Turbine/Generator.

The various frame configurations covered in this manual are listed in Sections 2.1 through 2.3 with differences as related to connective hardware defined. Listed also are the pertinent hardware drawings (HF-xxxx). These drawings as well as tooling drawings (HT-xxxx) form part of this manual.

2.1 Frame 9FA Gas Turbine to 324 Generator

GE Part Number	Riverhawk P/N	GE VENDOC P/N
358A7202P040	HF-0772	GE 359B2517

The hydraulic tooling used for installation and removal is Riverhawk HT-7046.

These hardware drawings depict the complete stud and nut package for the Gas Turbine to Load Coupling (2-3/4" size, Qty 18) and Load Coupling to Generator (2-3/4" size, Qty 16).

GE Part Number	Riverhawk P/N	GE VENDOC P/N
358A7202P044	HF-2578	GE 359B2545

The hydraulic tooling used for installation and removal is Riverhawk HT-7047.

These hardware drawings depict the complete stud and nut package for the Gas Turbine to Load Coupling (2-3/4" size, Qty 18) and Load Coupling to Generator (2-3/4" size, Qty 16).

2.2 Frame 9FA Gas Turbine to Load Coupling

GE Part Number	Riverhawk P/N	GE VENDOC P/N
358A7202P041	HF-0962	GE 359B2509
358A7202P047	HF-0962	GE 359B2509

The hydraulic tooling used for installation and removal is Riverhawk HT-7046.

These hardware drawings depict the complete stud and nut package for the Gas Turbine to Load Coupling (2-3/4" size, Qty 18).

CUSTOMER'S INFORMATION BOX

CONTENTS ARE INDEPENDENT OF RIVERHAWK DOCUMENT CONTROL



215 Clinton Road
 New Hartford, NY 13413
 Tel: +1 315 768 4855
 Fax: +1 315 768 4941
 Email: info@riverhawk.com

GE DRAWING NUMBER	REV
373A4094	

Revision F
 Page 5 of 37

GE Part Number	Riverhawk P/N	GE VENDOC P/N
358A7202P037	HF-0962	GE 359B2509
358A7202P045	HF-2580	GE 359B2547

The hydraulic tooling used for installation and removal is Riverhawk HT-7047 or HT-11460.

These hardware drawings depict the complete stud and nut package for the Gas Turbine to Load Coupling (2-3/4" size, Qty 18).

2.3 Load Coupling or Steam Turbine to 324 Generator

GE Part Number	Riverhawk P/N	GE VENDOC P/N
358A7202G0001	HF-0802	GE 359B2519
358A7202P0019	HF-0802	GE 359B2519
112T8262G0001	HF-0802	GE 359B2519
808L5279G0001	HF-0802	GE 359B2519

The hydraulic tooling used for installation and removal is Riverhawk HT-7046.

These hardware drawings depict the complete stud and nut package for the Load Coupling or Steam Turbine to Generator (2-3/4" size, Qty 16).

2.4 Hydraulic Tooling

GE Part Number	Riverhawk P/N	GE VENDOC P/N
358A7202P0043	HT-7046	GE 101B0670
	AP-0532	GE 359B2502
358A7202P046	HT-7047	GE 101B0671
	AP-0532	GE 359B2502
358A7202P048	HT-7047	GE 101B0671
	AP-0532	GE 359B2502
	HT-11460	GE 102B0834

CUSTOMER'S INFORMATION BOX

CONTENTS ARE INDEPENDENT OF RIVERHAWK DOCUMENT CONTROL



215 Clinton Road
 New Hartford, NY 13413
 Tel: +1 315 768 4855
 Fax: +1 315 768 4941
 Email: info@riverhawk.com

GE DRAWING NUMBER	REV
373A4094	

3.0 Quick Checklist

The following checklist is intended as a summary of the steps needed to use the Riverhawk-supplied equipment. New personnel or those experienced personnel who have not used the Riverhawk equipment recently are encouraged to read the entire manual.

EQUIPMENT INSPECTION

- Check oil level in hydraulic pump.
- Check air pressure at 80psi [5.5 bar] minimum. (For air-driven pumps)
- Check hydraulic hose for damage.
- Test the pump.
- Inspect tensioner for any damage.

NUT AND STUD PREPARATION

- Inspect studs and nuts for any damage.
- Clean the studs and nuts.
- Measure stud lengths. (VERY IMPORTANT)
- Lubricate the stud's threads with clean turbine oil or spray lubricant. Lubricate the nut's threads and nut face with clean turbine oil or spray lubricant.
- Install studs and nuts into the flange.
- Set stick-out dimension on the coupling/steam turbine side of the flange.
- Hand tighten nuts on the generator side of flange.
- Verify stick-out measurement (**VERY IMPORTANT**)

CUSTOMER'S INFORMATION BOX

CONTENTS ARE INDEPENDENT OF RIVERHAWK DOCUMENT CONTROL



215 Clinton Road
 New Hartford, NY 13413
 Tel: +1 315 768 4855
 Fax: +1 315 768 4941
 Email: info@riverhawk.com

GE DRAWING NUMBER	REV
373A4094	

TENSIONING (Bolt Installation)

- Check tensioner drawing for correct parts and part numbers.
- Apply a light coat of clean turbine oil or spray lubricant to the puller screw. **DO NOT USE “NEVER SEIZE” ON THE CONICAL THREADS.**
- Install the spanner ring onto the load coupling or steam turbine side’s nut depending on the powertrain configuration.
- Install one puller screw release tape strip into stud. See IM-336 (GE 373A4074).
- Install the tensioner on the stud in flange.
- Insert 1/2” hex Allen wrench into the back side of the stud.
- Tighten the puller screw. Then back off puller screw 1/2 a turn.
- Retighten the puller screw and leave tight. **DO NOT BACK OFF PULLER SCREW.**
- Place the guard over the tensioner positioning the guide pin into the backside of the stud and the tensioner handle into the locating slot in the guard.
- Hand-tighten the guard’s clamping screw. It should press firmly against tensioner’s puller screw.
- Push interlock knob to insert interlock screw into port on the tensioner and tighten firmly.
- Tension to 50%. Consult manual for correct pressure.
- Use the pin wrench in spanner ring to tighten nut.
- Release pressure, move to next stud in pattern.
- Repeat above steps at final pressure.
- Measure final stud length and record on stretch datasheets. Calculate stretch.

CUSTOMER'S INFORMATION BOX

CONTENTS ARE INDEPENDENT OF RIVERHAWK DOCUMENT CONTROL



215 Clinton Road
New Hartford, NY 13413
Tel: +1 315 768 4855
Fax: +1 315 768 4941
Email: info@riverhawk.com

GE DRAWING NUMBER	REV
373A4094	

- Torque the nuts' set screws.

DETENSIONING (Stud Removal)

- Loosen nuts' set screws
- Inspect and clean studs' conical threads. **Do not continue until ALL debris is removed from the threads!** See instruction manual IM-220 (GE 373A4025). **Do not try to use the tensioner to remove a damaged stud!**
- Apply a light coat of clean turbine oil or spray lubricant to the puller screw. **DO NOT USE "NEVER SEIZE" ON THE CONICAL THREADS.**
- Install the spanner ring onto the load coupling or steam turbine side's nut depending on the powertrain configuration.
- Install the tensioner on the stud in flange.
- Tighten the puller screw. Then back off puller screw 1/2 a turn.
- Retighten the puller screw and leave tight. **DO NOT BACK OFF PULLER SCREW.**
- Place the guard over the tensioner positioning the guide pin into the backside of the stud and the tensioner handle into the locating slot in the guard.
- Hand-tighten the guard's clamping screw. It should press firmly against tensioner's puller screw.
- Push interlock knob to insert interlock screw into port on the tensioner and tighten firmly.
- Apply final pressure.
- Loosen nut with the spanner ring and pin wrench.
- Move to next stud in pattern

CUSTOMER'S INFORMATION BOX

CONTENTS ARE INDEPENDENT OF RIVERHAWK DOCUMENT CONTROL



215 Clinton Road
New Hartford, NY 13413
Tel: +1 315 768 4855
Fax: +1 315 768 4941
Email: info@riverhawk.com

GE DRAWING NUMBER	REV
373A4094	

4.0 General Preparations

Read and understand all instructions before installing and tensioning studs.

Operators should be trained or have previous experience using Riverhawk tensioning equipment. Training will minimize the chance of improper use of the equipment.

The hydraulic tooling including the hydraulic hoses should be inspected prior to use. Inspection guidelines are listed in the following sub-sections.

This equipment produces very high hydraulic pressures and very high forces. Operators must exercise caution and wear the appropriate personal protective equipment when handling and operating the hydraulic tooling.

High-pressure oil from the hydraulic pump pressurizes the tensioner which generates a very large force that actually stretches the stud. As the stud is stretched the nut lifts off the flange. The nut is then turned by hand using the supplied spanner ring. Once the nut is tight against the flange, the pressure in the tensioner is released. The hardware is now clamping the flange together.

4.1 Machine Preparation

The flange to be tensioned must be fully closed prior to positioning of studs in the flanges. Turning the turbine and generator shafts is not required, but may be useful. Also, it will be advantageous to remove as many obstructions as possible from the flange area, such as speed probes, shipping plates, and conduit.

4.2 Hardware – Balance

The studs are supplied in component balanced sets. A stud can be exchanged with another in its set without affected the overall balance of the equipment. Do not exchange a stud from one set with another stud from a different set. When shipped from Riverhawk, the studs are not assigned to any specific hole in the load coupling flange; this is optional and can be done at the installation site. The set size is determined by the relevant GE order drawing (see section 2.0).

The nuts are supplied in component balanced sets. A nut can be exchanged with another in its set without affecting the overall balance of the equipment. Do not exchange a nut from one set with another nut from a different set. When shipped from Riverhawk, the nuts are not assigned to any specific hole in the load coupling flange; this is optional and can be done at the installation site. The set size is determined by the relevant GE order drawing (see section 2.0).

CUSTOMER'S INFORMATION BOX

CONTENTS ARE INDEPENDENT OF RIVERHAWK DOCUMENT CONTROL

GE DRAWING NUMBER	REV
373A4094	



215 Clinton Road
New Hartford, NY 13413
Tel: +1 315 768 4855
Fax: +1 315 768 4941
Email: info@riverhawk.com

A weight balance certification is supplied with each order. Store this certification in an appropriate location as it will be needed for the purchase of replacement equipment.

4.3 Tensioner – Care and Handling

When not in use, the tensioner shall be maintained in a clean environment and all caps and plugs for hydraulic openings and fittings must be in place.

Use ISO 32 grade oil.

When in use, the tensioner shall be protected from sand and grit.

See section 12 for long term storage requirements.

4.4 Hand Tools

Several hand wrenches and micrometers will be required to perform installation and measurement of the studs:

- 5/8" Wrench
- 3' to 4' Breaker Bar
- 1/2" Drive Ratchet
- A set of Allen Wrenches
- 12" to 13" Micrometer

4.5 Special Tools

- | | |
|---------------------------|--|
| Hydraulic Tensioner Kits: | HT-7046 Hydraulic Tensioner, 2-3/4"
(reference GE VENDOC 101B0670) |
| | HT-7047 Hydraulic Tensioner, 2-3/4"
(reference GE VENDOC 101B0671) |
| | HT-11460 Hydraulic Tensioner, 2-3/4"
(reference GE VENDOC 102B0834) |

CUSTOMER'S INFORMATION BOX

CONTENTS ARE INDEPENDENT OF RIVERHAWK DOCUMENT CONTROL



215 Clinton Road
New Hartford, NY 13413
Tel: +1 315 768 4855
Fax: +1 315 768 4941
Email: info@riverhawk.com

GE DRAWING NUMBER	REV
373A4094	

Hydraulic Pump Kit:

AP-0532 Air-Operated Hydraulic Pump
(recommended)
(reference GE VENDOC 359B2502)

MP-0130 Manual Hand-Operated Hydraulic Pump
(reference GE VENDOC 359B2506)

CAUTION

Riverhawk recommends that the tensioners be returned to Riverhawk for periodic inspections. Replacement of obsolete tensioners is recommended. Functional upgrades are also recommended. The Riverhawk Service Returns Coordinator should be notified 3-6 months prior to a planned outage to schedule an inspection service.

5.0 Hardware Set Preparations

5.1 Nut Preparation

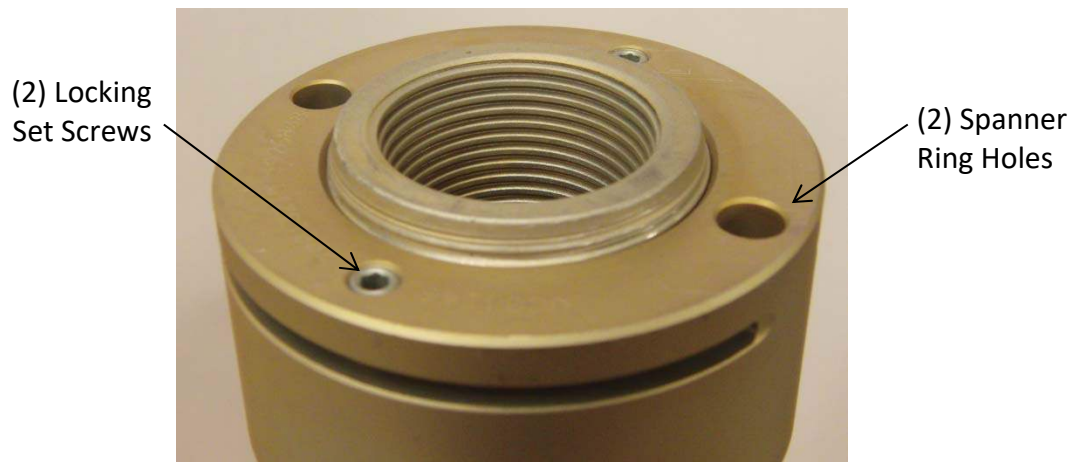

Picture 5A - Riverhawk Locknut

If there is any visible damage on a nut, do not use the nut and contact the Riverhawk Company for a replacement nut. Please be prepared to supply the turbine number, weight certification, and digital photographs for evaluation.

CUSTOMER'S INFORMATION BOX

CONTENTS ARE INDEPENDENT OF RIVERHAWK DOCUMENT CONTROL

GE DRAWING NUMBER	REV
373A4094	



215 Clinton Road
New Hartford, NY 13413
Tel: +1 315 768 4855
Fax: +1 315 768 4941
Email: info@riverhawk.com

5.1.1 Nut Cleaning - New Installations

For new installations, the nuts should come sealed from the factory and will need no cleaning.

5.1.2 Nut Cleaning - Old Installations

Previously installed nuts require cleaning as follows: Wire brush using a petroleum-based solvent to remove any foreign material on the external surfaces and threads.

5.2 Stud Preparation

Check the stud for any visible damage. If there is any visible damage, do not use the stud and contact the Riverhawk Company for a replacement stud. Please be prepared to supply the turbine number, weight certification, and digital photographs for evaluation.

CAUTION

It is especially important to check the condition of the conical thread used to tension the stud. Thread damage from previous abuse can lead to failure of the stud or tensioning equipment.

The conical threads of each stud must be clean of grit and dirt before installation or removal. This ensures the proper seating of the puller screw.

5.2.1 Stud Cleaning - New Installations

For new installations, the studs should come sealed from the factory and will need no cleaning.

5.2.2 Stud Cleaning - Old Installations

Previously installed studs may require cleaning using Riverhawk Stud Cleaning Kit GT-4253 (GE 373A4026). Clean internal conical threads should have a bright and shiny appearance.

Follow instruction manual IM-220 (GE 373A4025) for the cleaning procedure for the conical threads on Riverhawk studs. The latest revision may be obtained by contacting Riverhawk Company or thru www.riverhawk.com.



Picture 5B - Brass Power Brush

CUSTOMER'S INFORMATION BOX

CONTENTS ARE INDEPENDENT OF RIVERHAWK DOCUMENT CONTROL

GE DRAWING NUMBER	REV
373A4094	



215 Clinton Road
New Hartford, NY 13413
Tel: +1 315 768 4855
Fax: +1 315 768 4941
Email: info@riverhawk.com

Revision F
Page 13 of 37

5.3 Stud Length Measurement

Measure and record the initial lengths of the studs. The following suggestions will improve your results.

- Plan to start and finish any flange in the same day.
- Studs and flange must be at the same temperature.
- Number each stud with a marker for later stretch measurement tracking.
- Mark the location of measurement on stud end with a permanent marker.
- Measure each stud to nearest 0.001 inch (.01 mm).
- Record each measurement on the supplied record sheets.
- Do not allow the measuring instruments to sit in the sun.
- The same person should make all measurements.

6.0 Stud and Nut Assembly

Refer to the hardware assembly drawing (HF-xxxx) listed in Section 2.0 of this manual.

1. Assemble the cylindrical nut to the internal, conical thread end of the stud.
2. Slide the stud and cylindrical nut assembly into the flange as shown in Figures 6A and 6B.



215 Clinton Road
New Hartford, NY 13413
Tel: +1 315 768 4855
Fax: +1 315 768 4941
Email: info@riverhawk.com

CUSTOMER'S INFORMATION BOX

CONTENTS ARE INDEPENDENT OF RIVERHAWK DOCUMENT CONTROL

GE DRAWING NUMBER	REV
373A4094	

Revision F
Page 14 of 37

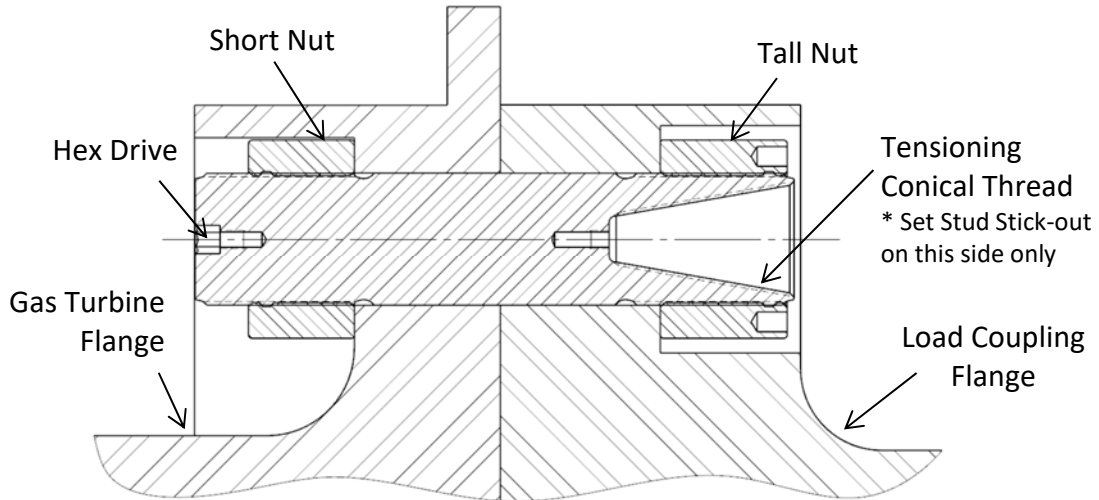

Figure 6A – Cross-section View of Gas Turbine to Load Coupling Bolted Flange Connection

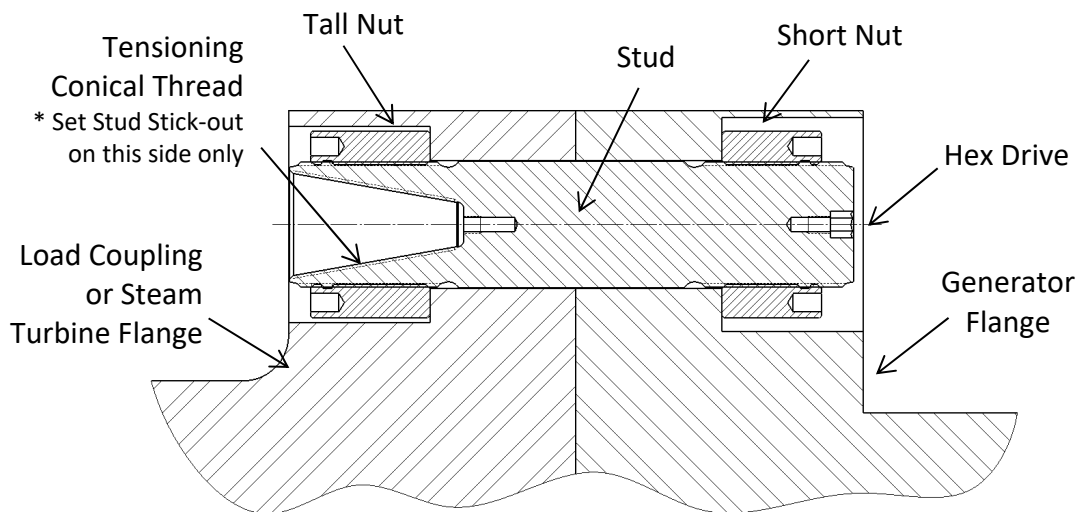

Figure 6B – Cross-section View of Load Coupling or Steam Turbine to Generator Bolted Flange Connection

3. Install the other nut on the backside.
4. Adjust the nut/stud assembly so that the stud protrudes (or sticks out) from the face of the cylindrical nut the distance specified on the hardware drawing (HF-xxxx). **SETTING THIS PROTRUSION OF STUD FROM THE NUT IS CRITICAL FOR PROPER TENSIONER**

CUSTOMER'S INFORMATION BOX

CONTENTS ARE INDEPENDENT OF RIVERHAWK DOCUMENT CONTROL



215 Clinton Road
 New Hartford, NY 13413
 Tel: +1 315 768 4855
 Fax: +1 315 768 4941
 Email: info@riverhawk.com

GE DRAWING NUMBER	REV
373A4094	

OPERATION. A metal stick-out gage is provided with the tensioner to assist the operator in setting the protrusion dimension.



Picture 6C –How to use the Stick-Out Gage to position the stud correctly on the Gas Turbine/Load Coupling bolted flange. The gage is only used on the Load Coupling side of the flange. Use the side of the gage labeled “Turbine End/Coupling Side”.



Picture 6D –How to use the Stick-Out Gage to position the stud correctly on the Load Coupling/Generator bolted flange or the Steam Turbine/Generator bolted flange. The gage is only used on the Load Coupling or Steam Turbine side of the flange. Use the side of the gage labeled “Generator End/Coupling Side”.

5. Hand tighten the assembly to a snug fit.
6. Recheck the stud stick-out length. If the stick-out length does not match the hardware drawing, adjust the nuts as necessary.

CUSTOMER'S INFORMATION BOX

CONTENTS ARE INDEPENDENT OF RIVERHAWK DOCUMENT CONTROL



215 Clinton Road
 New Hartford, NY 13413
 Tel: +1 315 768 4855
 Fax: +1 315 768 4941
 Email: info@riverhawk.com

GE DRAWING NUMBER	REV
373A4094	

7.0 Hydraulic Tensioner Equipment Assembly

7.1 Hydraulic Equipment Inspection

7.1.1 Hydraulic Tensioner Inspection

CAUTION

Riverhawk recommends that the tensioner be returned to Riverhawk for periodic inspections. Replacement of obsolete tensioners is recommended. Functional upgrades are also recommended. The Riverhawk Service Returns Coordinator should be notified 3-6 months prior to a planned outage to schedule an inspection service.

WARNING

To avoid failure, ensure safety, and proper operation, the tensioner assembly must be installed on a stud in the flange before pressurizing the tensioner. Do not use the tensioner at any pressure unless the tool is installed on a stud in a flange.

Check puller screw usage life with Riverhawk service bulletin SB-08001.

Clean puller screw and check for any debris and dents.

Puller screw should be free to rotate and move back and forth.

Seam between cylinders closed tightly.

Inspect the tensioner guard for any signs of damage including cracked welds. Any guards modified in the field should be replaced. Bent guards should be replaced.

Inspect the outside of the tensioner for discoloration patterns that may indicate submersion and internal damage.

Perform an inventory of the loose equipment supplied with the tensioner. An inventory list is provided on the tensioner's technical drawing (for example Riverhawk HT-xxxx). Replacement parts are available from Riverhawk.

7.1.2 Hydraulic Pump Kit Inspection

Refer to the Hydraulic Pump Kit Instruction Manual, IM-293 (GE VENDOC 373A4058). The latest revision may be obtained by contacting Riverhawk Company or thru www.riverhawk.com.

CUSTOMER'S INFORMATION BOX

CONTENTS ARE INDEPENDENT OF RIVERHAWK DOCUMENT CONTROL



215 Clinton Road
New Hartford, NY 13413
Tel: +1 315 768 4855
Fax: +1 315 768 4941
Email: info@riverhawk.com

GE DRAWING NUMBER	REV
373A4094	

Revision F
Page 17 of 37

8.0 Assembly of Tensioner on a Stud

8.1 Handling of the Tensioner

A strap can be placed around the cylinder lifting handle on the hydraulic connection side only to help the operator support the tensioner during installation. The lifting strap must be loose during tensioning.

8.2 Kit Assembly

Refer to the hardware assembly drawing (HF-xxxx) listed in Section 2.0 of this manual and the tensioner assembly drawing (HT-xxxx) listed in Section 4.5 of this manual to determine which side of the flange the tensioner must be located on in order to use the tensioner properly.

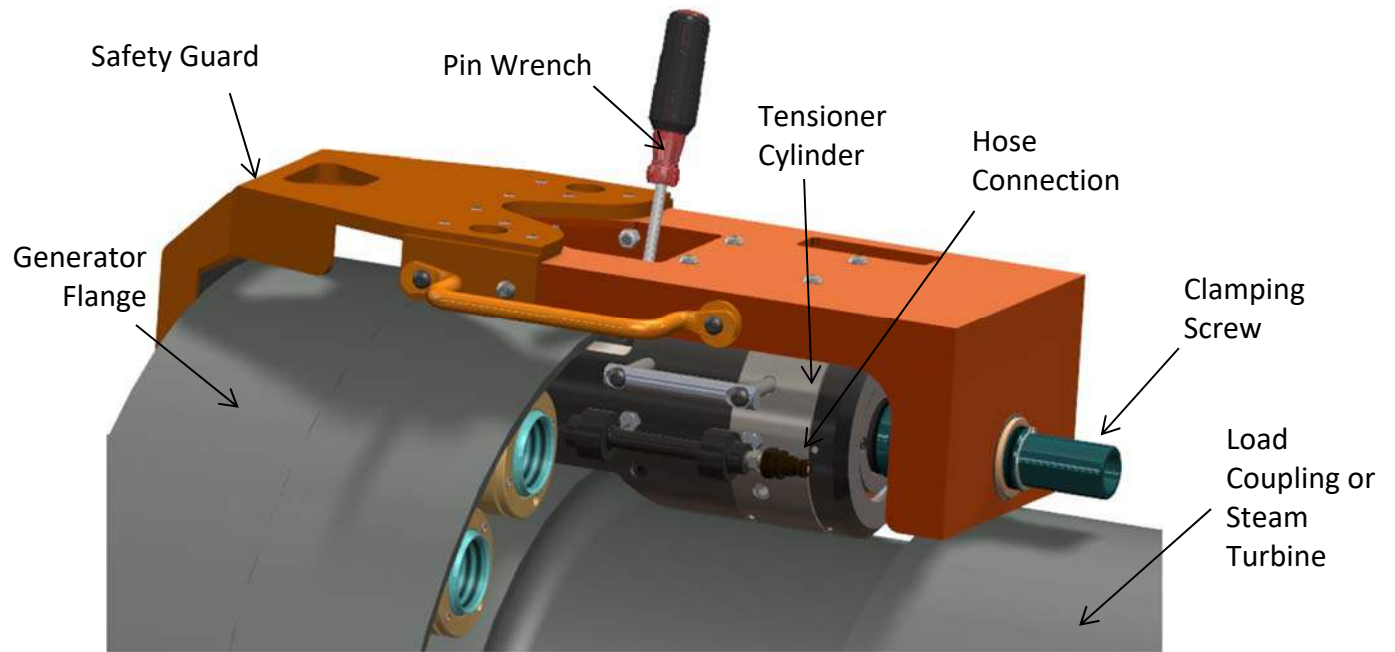

Picture 8A – Features of the Hydraulic Tensioner HT-7046

CUSTOMER'S INFORMATION BOX

CONTENTS ARE INDEPENDENT OF RIVERHAWK DOCUMENT CONTROL



215 Clinton Road
 New Hartford, NY 13413
 Tel: +1 315 768 4855
 Fax: +1 315 768 4941
 Email: info@riverhawk.com

GE DRAWING NUMBER	REV
373A4094	

Revision F
 Page 18 of 37

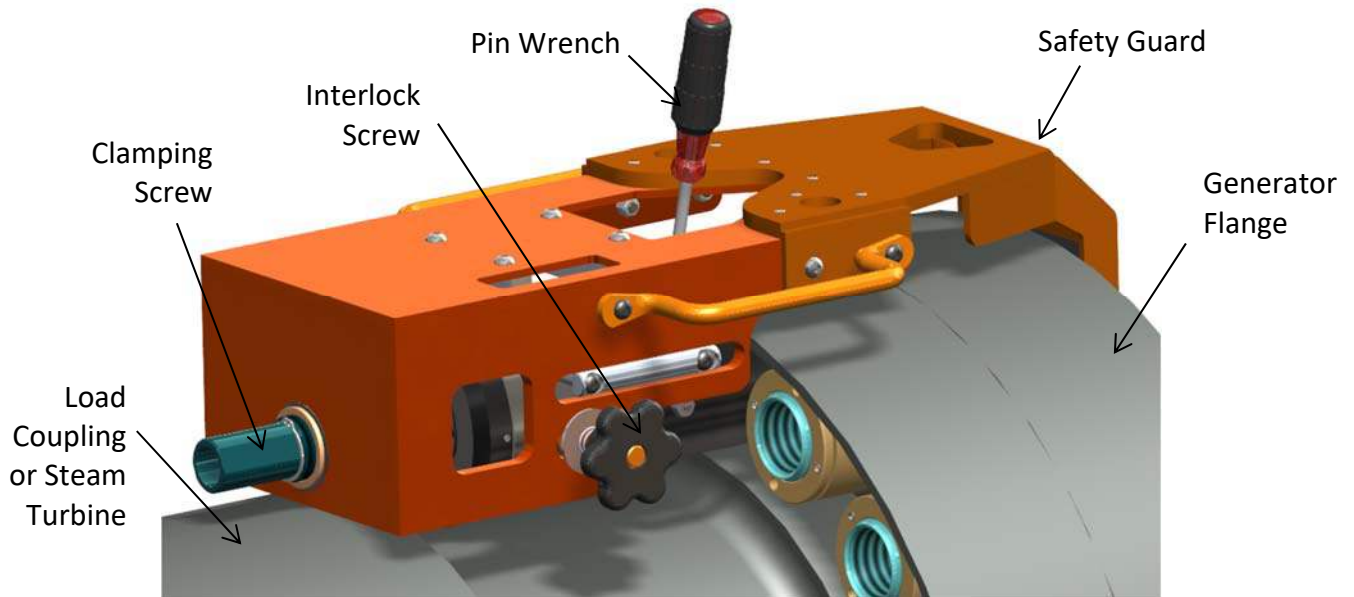

Picture 8B - Features of the Hydraulic Tensioner HT-7046

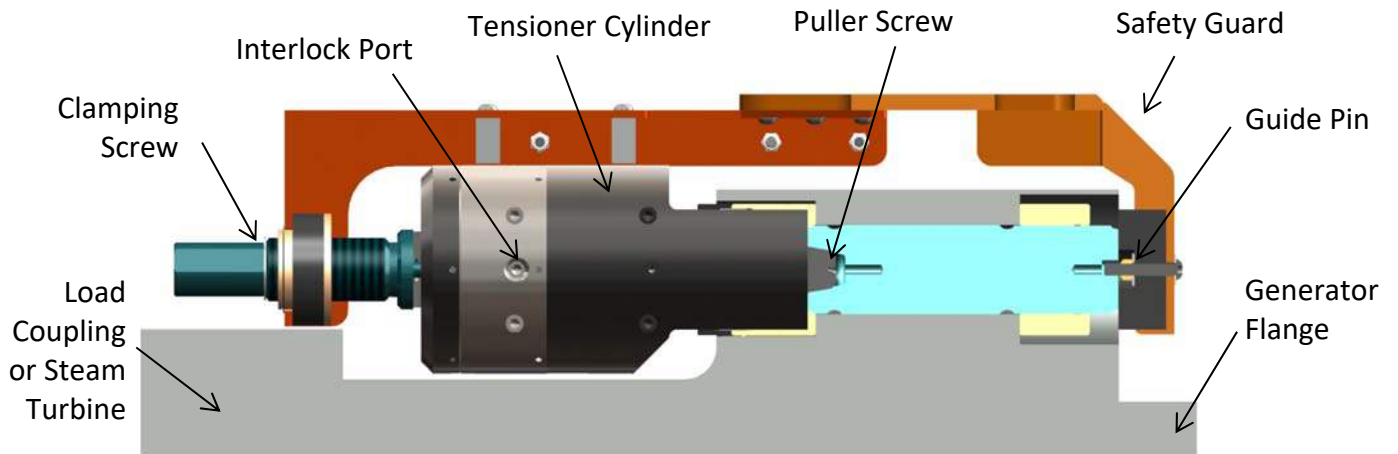

Picture 8C – Cutaway view of Hydraulic Tensioner HT-7046

CUSTOMER'S INFORMATION BOX

CONTENTS ARE INDEPENDENT OF RIVERHAWK DOCUMENT CONTROL



215 Clinton Road
 New Hartford, NY 13413
 Tel: +1 315 768 4855
 Fax: +1 315 768 4941
 Email: info@riverhawk.com

GE DRAWING NUMBER	REV
373A4094	

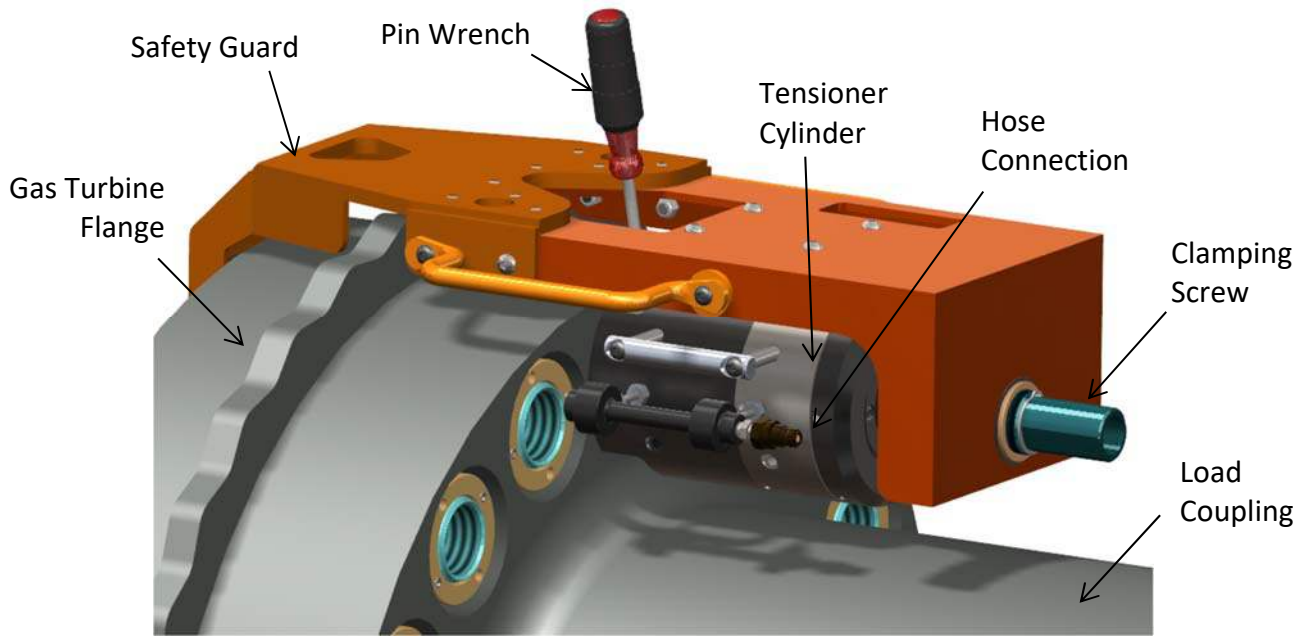

Picture 8D – Features of the Hydraulic Tensioner HT-7047/HT-11460

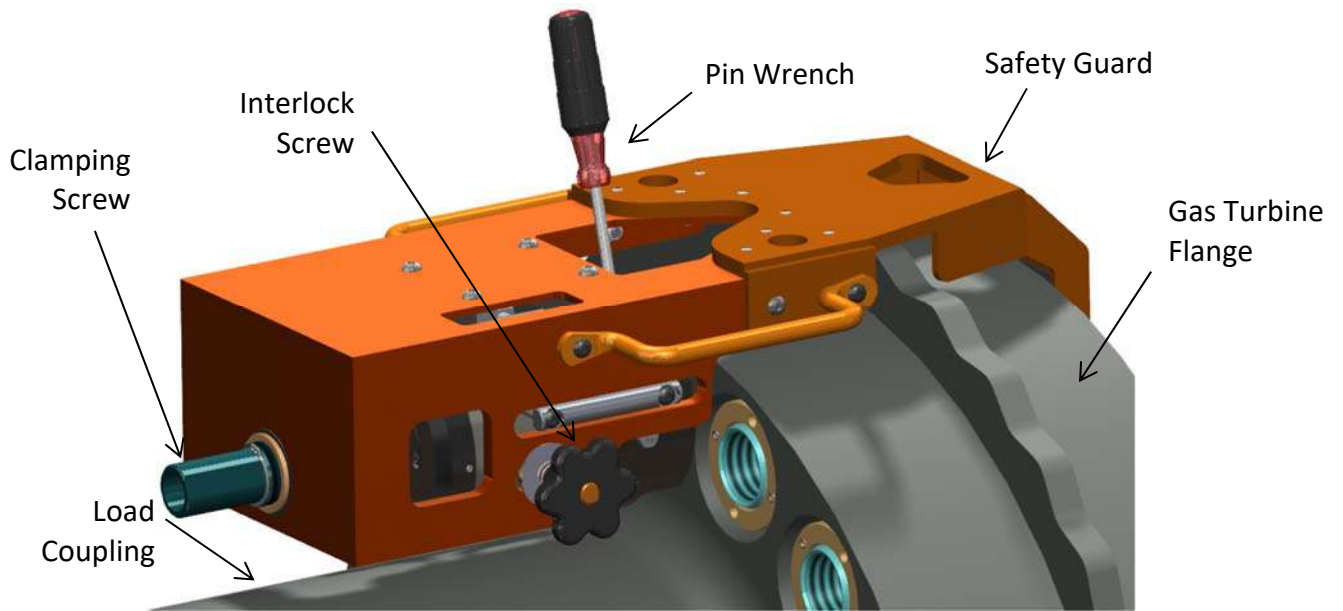

Picture 8E – Features of the Hydraulic Tensioner HT-7047/HT-11460

CUSTOMER'S INFORMATION BOX

CONTENTS ARE INDEPENDENT OF RIVERHAWK DOCUMENT CONTROL



215 Clinton Road
 New Hartford, NY 13413
 Tel: +1 315 768 4855
 Fax: +1 315 768 4941
 Email: info@riverhawk.com

GE DRAWING NUMBER	REV
373A4094	

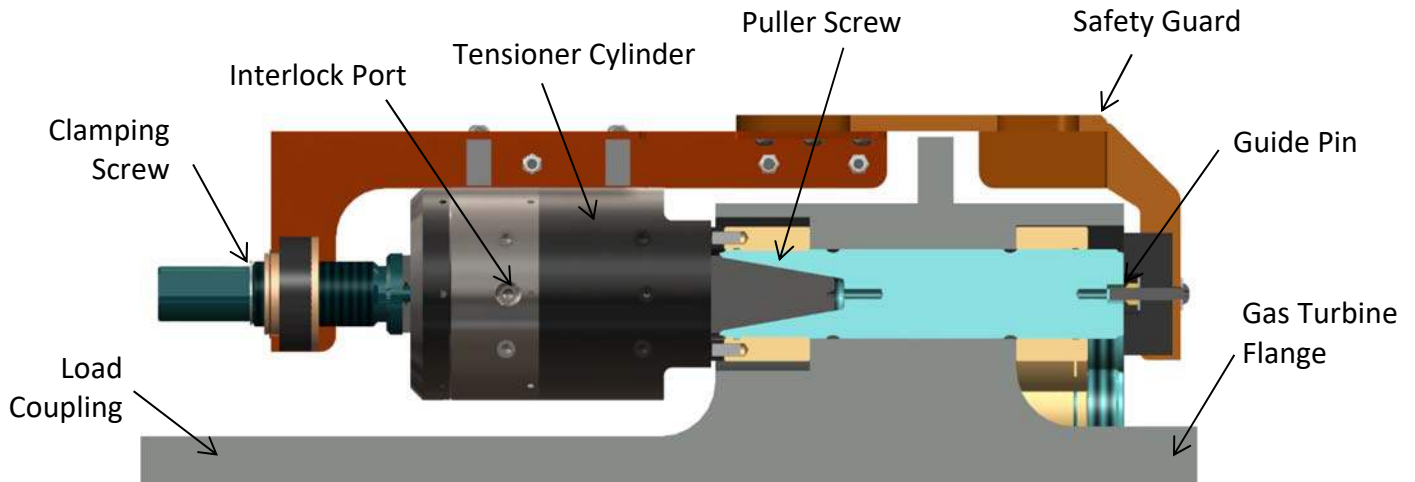

Picture 8F – Cutaway view of Hydraulic Tensioner HT-7047/HT-11460

Note: Before threading the puller screw into the stud, carefully check the cleanliness of both the stud's and the puller screw's conical threads. Apply a light coat of clean turbine oil or a spray lubricant to the puller screw. Do not use "Never Seize" on the conical threads. This procedure will ease assembly and assure positive mating of the threads before tightening.

Assembly sequence is as follows:

1. Open the hydraulic return valve on the pump to allow hydraulic fluid to be pushed back from the puller tool into the pump reservoir. (This is automatic on the air-operated hydraulic pump)
2. Depending on the powertrain configuration, place the spanner ring on the nut on either the load coupling side or the steam turbine side of the flange; aligning the pins in the spanner ring with the holes on the nut.
3. Apply a light coat of clean turbine oil or a spray lubricant to the puller screw. Do not use "Never Seize" on the conical threads.
4. Install one puller screw release tape strip into end of stud. See IM-336 (GE 373A4074)
5. Place and hold the tensioner assembly over the end of the stud to be tightened.
6. Slide the puller screw in to the tapered thread of the stud and hand tighten. **Be sure not to cross thread assembly.**

CUSTOMER'S INFORMATION BOX

CONTENTS ARE INDEPENDENT OF RIVERHAWK DOCUMENT CONTROL

GE DRAWING NUMBER	REV
373A4094	



215 Clinton Road
 New Hartford, NY 13413
 Tel: +1 315 768 4855
 Fax: +1 315 768 4941
 Email: info@riverhawk.com

7. Hold the stud steady with a 1/2" hex key wrench and using 1/2" drive ratchet wrench on end of puller screw. Tighten the puller screw into the conical thread of the stud with the ratchet wrench.
8. Back off the puller screw 1/2 a turn.
9. Retighten the puller screw.
10. At this point the Tensioner Assembly **MUST BE FREE TO ROTATE**, the puller screw must be tight in the stud. **DO NOT BACK OFF PULLER SCREW.**
11. Place guard assembly over top of cylinder and flange and position the guide pin into the hole in the backside of the stud.
12. Tighten the knurled clamping screw until it firmly presses against the tensioner puller screw with the screw pin inside of the 1/2 drive hole.
13. Align the interlock screw with the port on the cylinder. Tighten to firmly seat internal interlock valve.

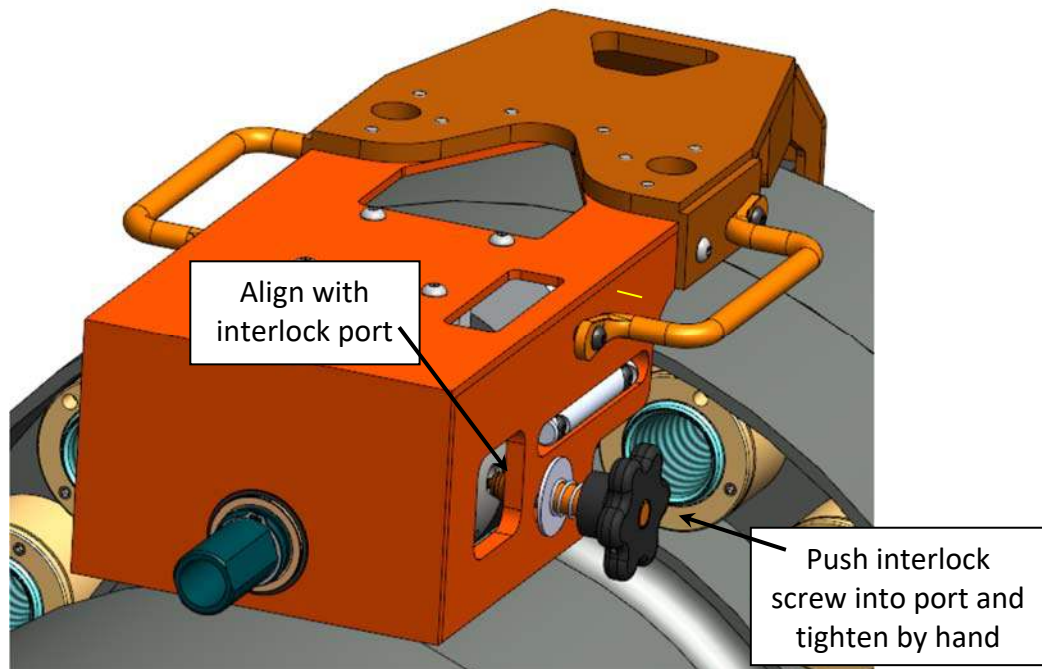

Picture 8D – Activation of Safety Interlock

14. Connect the hydraulic pump to the tensioner. The tensioner should be completely assembled and ready for use.

CUSTOMER'S INFORMATION BOX

CONTENTS ARE INDEPENDENT OF RIVERHAWK DOCUMENT CONTROL

GE DRAWING NUMBER	REV
373A4094	



215 Clinton Road
New Hartford, NY 13413
Tel: +1 315 768 4855
Fax: +1 315 768 4941
Email: info@riverhawk.com

If the tensioner is not free to rotate when the puller screw is tight then, either (1) the stud is not properly positioned in the flange and recheck the stick-out length and reposition the nuts, or (2) The tensioner is damaged and must be returned for repair.

CAUTION

Do not over extend the stud. Over extension can cause the piston to lose its seal and leak oil.

CAUTION

Personal injury and equipment damage can occur if the puller screw is not securely engaged with the tapered threads of the stud. Proper engagement is achieved when the puller screw is tight in the stud and the tensioner assembly is free to turn.

8.3 Air Bleeding Hydraulic System

Air bleeding of the hydraulic system is not necessary with this tensioner design.

9.0 Stud Tensioning

The studs will be tensioned in two steps, at 50% pressure and at final pressure. Follow the tensioning sequence for each flange joint as defined on the record sheets found at the end of this manual.

9.1 Tensioning at 50% pressure

After the tensioner is properly installed apply hydraulic pressure to the tool as described in section 8. Bring the pressure to the 50% level in accordance with the following table.

WARNING

The safety guard must be in place at all times. Keep hands out of designated areas at all times when the tensioner is pressurized otherwise personal injury can occur.

CAUTION

Before threading the puller screw into the stud, carefully check the cleanliness of both the stud's and the puller screw's conical threads. Apply a light coat of clean turbine oil or a spray lubricant to the puller screw. This procedure will ease assembly and assure positive mating of the threads before tightening. Do not use "Never Seize" on the conical threads.

CAUTION

CUSTOMER'S INFORMATION BOX

CONTENTS ARE INDEPENDENT OF RIVERHAWK DOCUMENT CONTROL



215 Clinton Road
New Hartford, NY 13413
Tel: +1 315 768 4855
Fax: +1 315 768 4941
Email: info@riverhawk.com

GE DRAWING NUMBER	REV
373A4094	

Do not exceed the maximum pressure marked on the tensioner. Excessive pressure can damage the stud and puller screw.

CAUTION

Do not tighten the nut while the tool is coming up to pressure; wait until pressure is achieved before attempting to tighten the nut with the spanner ring. If the tool is not properly installed, the tool could jump off the stud while coming up to pressure.

<u>Powertrain Position</u>	<u>Stud Size</u>	<u>50% Pressure</u>	<u>50% Stretch</u>
Gas Turbine to Coupling	2-3/4" [69mm]	10000 psi [690 bar]	Do not measure Do not use
Load Coupling to Generator	2-3/4" [71 mm]	10000 psi [690 bar]	Do not measure Do not use
Steam Turbine to Generator	2-3/4" [71 mm]	10000 psi [690 bar]	Do not measure Do not use

9.1.1 Tightening of 2-3/4" nuts

Turn the cylindrical nut using the spanner ring and pin wrench until it bottoms firmly on the flange.

9.2 Removing the Tensioner from an Installed Stud

The tensioner removal is accomplished by the follows steps:

1. Release the hydraulic pressure by either releasing the hand switch on the AP-0532 Pump Kit or by opening the valve on the MP-0130 Manual Pump Kit and leave the valve open.
2. Wait for the tensioner to fully retract and the tensioner is free to rotate.
3. Unscrew the hydraulic interlock knob until the screw is disconnected from the cylinder.
4. Unscrew the knurled clamping screw and remove the guard from the tensioner.
5. Unscrew the puller screw using a wrench or breaker bar. Do not use an impact wrench as this can damage the tensioner.
6. Remove the spanner ring from the nut.

CUSTOMER'S INFORMATION BOX

CONTENTS ARE INDEPENDENT OF RIVERHAWK DOCUMENT CONTROL



215 Clinton Road
New Hartford, NY 13413
Tel: +1 315 768 4855
Fax: +1 315 768 4941
Email: info@riverhawk.com

GE DRAWING NUMBER	REV
373A4094	

7. Move the tool to the next bolt hole following the tensioning pattern from the stretched record sheets at the end of this manual.

9.3 Tensioning at Final Pressure

Repeat the pulling and tightening procedure stated above at full pressure. After all of the studs have been tensioned, measure the final stud length. The final pressure and required stretch values are listed in the following table.

WARNING

The safety guard must be in place at all times. Keep hands out of designated areas at all times when the tensioner is pressurized otherwise personal injury can occur.

CAUTION

Before threading the puller screw into the stud, carefully check the cleanliness of both the stud's and the puller screw's conical threads. Apply a light coat of clean turbine oil or a spray lubricant to the puller screw. This procedure will ease assembly and assure positive mating of the threads before tightening. Do not use "Never Seize" on the conical threads.

CAUTION

Do not exceed the maximum pressure marked on the tensioner. Excessive pressure can damage the stud and puller screw.

CAUTION

Do not tighten the nut while the tool is coming up to pressure; wait until pressure is achieved before attempting to tighten the nut with the spanner ring. If the tool is not properly installed, the tool could jump off the stud while coming up to pressure.

<u>Powertrain Position</u>	<u>Stud Size</u>	<u>Final Pressure</u>	<u>Final Stretch</u>
Gas Turbine to Load Coupling	2-3/4" [69 mm]	17000 psi [1170 bar]	0.022" - 0.024" [0.56 mm - 0.61 mm]
Load Coupling to Generator	2-3/4" [71 mm]	19000 psi [1310 bar]	0.025" - 0.027" [0.64 mm - 0.69 mm]
Steam Turbine to Generator	2-3/4" [71 mm]	19000 psi [1310 bar]	0.025" - 0.027" [0.64 mm - 0.69 mm]

CUSTOMER'S INFORMATION BOX

CONTENTS ARE INDEPENDENT OF RIVERHAWK DOCUMENT CONTROL



215 Clinton Road
New Hartford, NY 13413
Tel: +1 315 768 4855
Fax: +1 315 768 4941
Email: info@riverhawk.com

GE DRAWING NUMBER	REV
373A4094	

Incorrect stretch values can be corrected by uninstalling some or all of the selected studs. Re-measure the initial length of the studs and repeat the installation instructions studs. Excessive stretch variations can also be corrected by the same method.

Have final stretch values approved by the supervisor responsible for the installation.

10.0 Thread Locking and Windage Plug Installation

10.1 Thread Locking



Picture 10A - Riverhawk Locknut

Mechanical lock nuts have two set screws located in the top face. Before threading the nut onto the stud check to be certain the set screws are free to turn. Once the nut is seated torque the set screws to the values specified in the following table. When seated and torqued to the values specified the load created by the set screw displaces the thread of the nut in the area of the web creating the desired locking action.

<u>Powertrain Position</u>	<u>Stud Size</u>	<u>Set Screw Size</u>	<u>Torque</u>
Gas Turbine to Load Coupling	2-3/4" [69 mm]	3/8"-24 UN	200 in·lbs – 250 in·lbs [22.6 N·m – 28.2 N·m]
Load Coupling to Generator	2-3/4" [71 mm]	3/8"-24 UN	200 in·lbs – 250 in·lbs [22.6 N·m – 28.2 N·m]

CUSTOMER'S INFORMATION BOX

CONTENTS ARE INDEPENDENT OF RIVERHAWK DOCUMENT CONTROL



215 Clinton Road
New Hartford, NY 13413
Tel: +1 315 768 4855
Fax: +1 315 768 4941
Email: info@riverhawk.com

GE DRAWING NUMBER	REV
373A4094	

Revision F
Page 26 of 37

Steam Turbine to Generator	2-3/4" [71 mm]	3/8"-24 UN	200 in·lbs – 250 in·lbs [22.6 N·m – 28.2 N·m]
-------------------------------	-------------------	------------	--

11.0 Stud and Nut Removal

11.1 Handling of the Tensioner

A strap can be placed around the cylinder lifting handle on the hydraulic connection side only to help the operator support the tensioner during installation. The lifting strap must be loose during tensioning.

11.2 Stud and Nut Removal

Removal is accomplished as follows:

- Using a wire brush, GT-4253, and shop air clean the internal tapered thread of the stud to remove any debris/deposits which may have accumulated during service as described in section 5.2.2.
- With an Allen-wrench loosen the two locking set screws but do not remove from the nut.



Picture 11A - Loosening of a nut's set screws

- Install the appropriate tensioner to the stud as described in Section 8.0.
- Apply the appropriate hydraulic pressure per this table. **DO NOT BACK OFF THE PULLER SCREW.**

CUSTOMER'S INFORMATION BOX

CONTENTS ARE INDEPENDENT OF RIVERHAWK DOCUMENT CONTROL



215 Clinton Road
New Hartford, NY 13413
Tel: +1 315 768 4855
Fax: +1 315 768 4941
Email: info@riverhawk.com

GE DRAWING NUMBER	REV
373A4094	

Revision F
Page 27 of 37

<u>Powertrain Position</u>	<u>Stud Size</u>	<u>Removal Pressure</u>
Gas Turbine to Load Coupling	2-3/4" [69 mm]	17000 psi [1170 bar]
Load Coupling to Generator	2-3/4" [71 mm]	19000 psi [1310 bar]
Steam Turbine to Generator	2-3/4" [71 mm]	19000 psi [1310 bar]

- Using the spanner ring and spanner/pin wrenches, loosen the nut, and then release the pressure.

11.3.1 Removing the Tensioner from a Stud

The tensioner removal is accomplished by the follows steps:

1. Release the hydraulic pressure by either releasing the hand switch on the AP-0532 Pump Kit or by opening the valve on the MP-0130 Manual Pump Kit and leave the valve open.
2. Wait for the tensioner to fully retract and the tensioner is free to rotate.
3. Unscrew the hydraulic interlock knob until the screw is disconnected from the cylinder.
4. Unscrew the knurled clamping screw and remove the guard from the tensioner.
5. Unscrew the puller screw using a wrench and breaker bar. Do not use an impact wrench as this can damage the tensioner.
6. Remove the spanner ring from the nut.
7. Move the tool to the next bolt hole following the tensioning pattern from the stretched record sheets at the end of this manual.

12.0 Storage Instructions

Follow these directions to properly store your hydraulic tensioner and hydraulic pump kit for long term storage and shipment.

If any damage is observed, contact the Riverhawk Company to schedule a maintenance inspection.

CUSTOMER'S INFORMATION BOX

CONTENTS ARE INDEPENDENT OF RIVERHAWK DOCUMENT CONTROL

GE DRAWING NUMBER	REV
373A4094	



215 Clinton Road
New Hartford, NY 13413
Tel: +1 315 768 4855
Fax: +1 315 768 4941
Email: info@riverhawk.com

12.1 Hydraulic Pump Kit Storage

Refer to the Hydraulic Pump Kit Instruction Manual, IM-293 (GE 373A4058). The latest revision may be obtained by contacting Riverhawk Company or thru www.riverhawk.com.

12.2 Hydraulic Tensioner Storage

Check the tensioner for any damage

1. Clean puller screw and check for any debris and dents.
2. Puller screw should be free to rotate and move back and forth.
3. Seam between cylinders closed tightly.
4. Inspect tensioner guard for any signs of damage. Bent guards should be replaced.

If any damage is observed, contact the Riverhawk Company to schedule a maintenance inspection.

Place protective red plastic cap into the hydraulic port.

Coat the hydraulic tensioner with a light coat of oil and place the tensioner into the original shipping container.

12.3 Store shipping container

Secure the hydraulic pump and hydraulic tensioner into the original shipping containers using the supplied wood braces.

Seal the original shipping container and store under shelter and protected from moisture, sand, and grit.

13.0 Frequently Asked Questions

This section contains some frequently asked questions and problems. If the steps listed here do not solve your problem, contact the Riverhawk Company thru our website, email, or phone call.

Q: Can I rent a hydraulic tensioner kit?

A: Yes, Riverhawk has rental tensioner kits available for most of our hydraulic tensioners.

CUSTOMER'S INFORMATION BOX

CONTENTS ARE INDEPENDENT OF RIVERHAWK DOCUMENT CONTROL

GE DRAWING NUMBER	REV
373A4094	



215 Clinton Road
New Hartford, NY 13413
Tel: +1 315 768 4855
Fax: +1 315 768 4941
Email: info@riverhawk.com

Q: A tensioner has pulled itself out of the stud's conical threads. Can I continue using a tensioner on this stud?

A: No. Both the tensioner and the stud may have been damaged and must be removed from the work area. If the stud is tensioned, a Nut Buster repair kit, from Riverhawk, must be used to remove the damaged stud by drilling out the nut. Leaving a damaged stud in place will lead to a safety hazard on future outages.

Riverhawk can supply a replacement stud and nut based on the initial weight certification supplied with the hardware set (see section 4.2). The damaged tensioner should also be returned to Riverhawk for inspection and repair.

If a stud must be left in place, paint the damaged stud with a generous amount of indelible, bright-colored paint. Notify the appropriate GE Safety and Service personnel. Note the location of the damaged stud in the services notes for the machine.

Q: The hydraulic tensioner has been taken up to its final pressure. The final stretch length is short of the final stretch target. What is the next step?

A: Do not increase the hydraulic pressure. Check if the hydraulic pump is set to the right pressure. Install the tensioner and re-pressurize the tensioner to the final pressure then recheck the stretch measurement. If the stretch value is still short, remove the stud from the hole and re-measure the stud's initial length then try to install the stud again.

Q: The hydraulic tensioner has been taken up to its final pressure. The final stretch length is larger than the final stretch target. What is the next step?

A: Remove the stud from the bolt hole. Check if the hydraulic pump is set to the right pressure. Re-measure the stud's initial length then try to install the stud again.

CUSTOMER'S INFORMATION BOX

CONTENTS ARE INDEPENDENT OF RIVERHAWK DOCUMENT CONTROL



215 Clinton Road
New Hartford, NY 13413
Tel: +1 315 768 4855
Fax: +1 315 768 4941
Email: info@riverhawk.com

GE DRAWING NUMBER	REV
373A4094	

- Q:** The tensioner is at its final pressure, but the nut cannot be loosened.
- A:** If the nuts cannot be loosened at the final pressure, continually increasing the pressure will not help and can be dangerous and in some cases make it harder to remove the nut. Check the nut to see if its set screws have been loosened. Check for and remove any corrosion around the nut's threads.
- Q:** How do I clean the conical threads on a stud?
- A:** The conical threads are best cleaned using a spiral wound brass brush in a drill as described in section 5.2.2
- Q:** During the initial steps of removing a tensioned stud, the stick-out length is found to be wrong.
- A:** Do not proceed. Contact Riverhawk for assistance. With the wrong stick-out length, the hydraulic tensioner has a limited stroke and may not work properly and can be damaged.
- Q:** The hydraulic pump appears to be leaking.
- A:** Check the hose connection to the hydraulic pump. If the 1/4" high pressure fitting is not assembled correctly as shown in Appendix B2, it may look like the pump is leaking. If the problem continues, it may be necessary to open the pump kit. Contact Riverhawk for guidance.
- Q:** The hydraulic hose has a collar on it that can't be moved by hand
- A:** The hydraulic fitting is shown in Appendix B2. The collar is sometimes held in place with a thread locking compound. This prevents the collar from moving too easily. It may be necessary to adjust this collar with a set of vise-grip pliers. Be careful to not strip the threads off the tube or hose end.

CUSTOMER'S INFORMATION BOX

CONTENTS ARE INDEPENDENT OF RIVERHAWK DOCUMENT CONTROL



215 Clinton Road
New Hartford, NY 13413
Tel: +1 315 768 4855
Fax: +1 315 768 4941
Email: info@riverhawk.com

GE DRAWING NUMBER	REV
373A4094	

14.0 Revision History

Revision Letter	Effective Date	Description
F	Jun 9, 2026	Added HT-11460 to section 2 and 4.5
E	Apr 4, 2022	Updated EC Declaration of Conformity; Added UKCA Declaration of Conformity
D	Jan 12, 2021	Removed air bleeding reference from warning statement in section 1.0
C	Nov 28, 2018	2-3/4" Stud size for Gas Turbine to Load Coupling position was incorrectly identified as 2-1/4" in sections 9.1, 9.3, 10.1, and 11.2
B	Aug 21, 2018	Added Frame 9FA Gas Turbine to 324 Generator, 358A7202P040, 358A7202P041, 358A7202P044, 358A7202P045, 358A7202P046, 358A7202P047 to title page and section 2
A	Jul 1, 2016	Added Frame 9FA Gas Turbine to Load Coupling, 358A7202P038, 358A7202P048 to Title page; Inserted section 2.1; Added HT-7047 to section 4.5; Inserted figure 6A and picture 6C to section 6.0; Added pictures 8D, 8E, 8F to section 8.2; Added Gas Turbine to Load Coupling to pressure tables in sections 9.1, 9.3, 11.2; Added Gas Turbine to Load Coupling to torque table in section 10.1
-	Jun 21, 2016	Released

CUSTOMER'S INFORMATION BOX

CONTENTS ARE INDEPENDENT OF RIVERHAWK DOCUMENT CONTROL



215 Clinton Road
 New Hartford, NY 13413
 Tel: +1 315 768 4855
 Fax: +1 315 768 4941
 Email: info@riverhawk.com

GE DRAWING NUMBER	REV
373A4094	

Appendix A1 – EC Declaration of Conformity

Manufacturer: Riverhawk Company
Address: 215 Clinton Road
New Hartford, NY 13413, USA

The hydraulic pump and bolt tensioning tool described in this manual are used for installing and applying tension to large bolts that are specifically designed by Riverhawk Company to be tensioned hydraulically.

All applicable sections of European Directive 2006/42/EC for machinery have been applied and fulfilled in the design and manufacture of the hydraulic pump and bolt tensioning tool described in this manual. Reference also ISO 12100:2010, ISO 4413:2010, and ISO 4414:2010.

Furthermore, this equipment has been manufactured under the Riverhawk quality system per EN ISO 9001:2015

Consult the Declaration of Conformance included with the shipment of this equipment that identifies the authorized Riverhawk representative, applicable serial numbers, and appropriate signature.

CUSTOMER'S INFORMATION BOX

CONTENTS ARE INDEPENDENT OF RIVERHAWK DOCUMENT CONTROL

GE DRAWING NUMBER	REV
373A4094	



215 Clinton Road
New Hartford, NY 13413
Tel: +1 315 768 4855
Fax: +1 315 768 4941
Email: info@riverhawk.com

Appendix A2 – UKCA Declaration of Conformity

Manufacturer: Riverhawk Company
Address: 215 Clinton Road
New Hartford, NY 13413, USA

The hydraulic pump and bolt tensioning tool described in this manual are used for installing and applying tension to large bolts that are specifically designed by Riverhawk Company to be tensioned hydraulically.

All applicable sections of Supply of Machinery (Safety) 2008 have been applied and fulfilled in the design and manufacture of the hydraulic pump and bolt tensioning tool described in this manual. Reference also ISO 12100:2010, ISO 4413:2010, and ISO 4414:2010.

Furthermore, this equipment has been manufactured under the Riverhawk quality system per EN ISO 9001:2015

Consult the Declaration of Conformance included with the shipment of this equipment that identifies the authorized Riverhawk representative, applicable serial numbers, and appropriate signature.

CUSTOMER'S INFORMATION BOX

CONTENTS ARE INDEPENDENT OF RIVERHAWK DOCUMENT CONTROL

GE DRAWING NUMBER	REV
373A4094	



215 Clinton Road
New Hartford, NY 13413
Tel: +1 315 768 4855
Fax: +1 315 768 4941
Email: info@riverhawk.com

Appendix B1 - Hydraulic Fittings

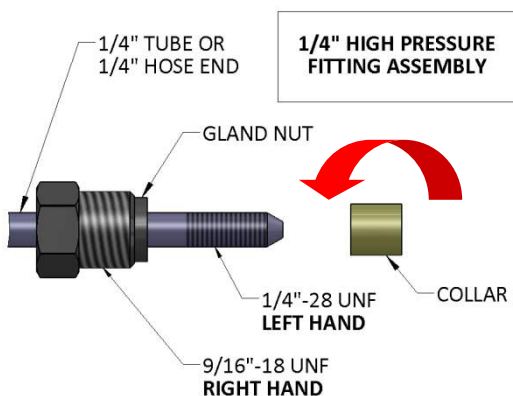

Illustration 1

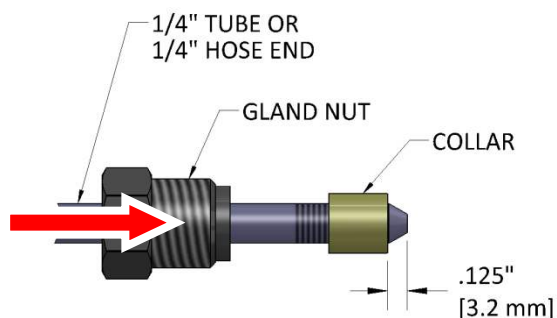

Illustration 2

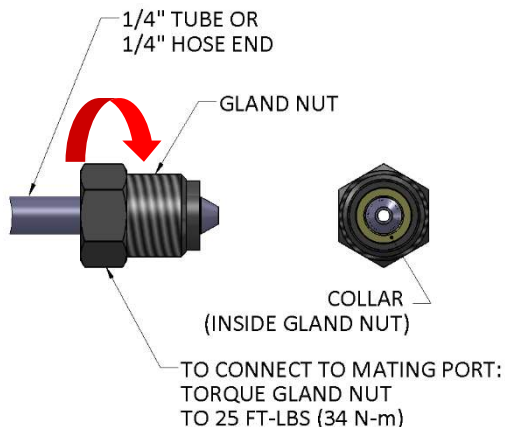

Illustration 3

Riverhawk tensioners use a 1/4" High Pressure port to connect its hydraulic hoses. The hose connector is made from a three piece assembly: a gland nut, a collar, and a 1/4" tube or 1/4" hose end. (See Illustration 1)

To assembly the fitting, slide the gland nut over the 1/4" tube or 1/4" hose end. Turn the collar counter-clockwise (**left hand** thread) on to the tube or hose end as shown in Illustration 1.

The collar should be placed .125" (3.2 mm) from the tip of the cone. (See Illustration 2) It may be necessary to adjust this collar with a set of vise-grip pliers. Be careful to not strip the threads off the tube or hose end.

Slide the gland nut down over the collar. (See Illustration 3) Insert the 1/4" tube or 1/4" hose end into tensioner or hydraulic pump. While firmly holding the tube or hose end to stop it from rotating, turn the gland nut clockwise (**right hand** thread) and torque the gland nut to 25 FT-LBS (34 N-m).

Tips:

- Make sure all parts are clean and free from debris.
- Protect the cone on the end of the 1/4" tube or 1/4" hose end from scratches as this is the sealing surface.
- Replace red plastic caps when finished to protect the threads and cone.

CUSTOMER'S INFORMATION BOX

CONTENTS ARE INDEPENDENT OF RIVERHAWK DOCUMENT CONTROL

GE DRAWING NUMBER	REV
373A4094	



215 Clinton Road
 New Hartford, NY 13413
 Tel: +1 315 768 4855
 Fax: +1 315 768 4941
 Email: info@riverhawk.com

Appendix C1 - Record Sheet 18 Bolt Circle

STRETCH RECORD SHEET FOR
THE GAS TURBINE TO LOAD COUPLING

TURBINE NUMBER:

DATE:

TECHNICIAN:

SUPERVISOR:

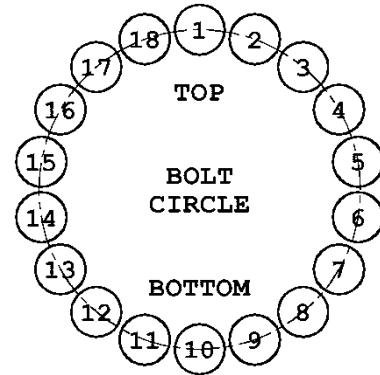

HOLE NUMBER	STARTING LENGTH	FINAL LENGTH	FINAL STRETCH
1			
10			
2			
11			
3			
12			
4			
13			
5			
14			
6			
15			
7			
16			
8			
17			
9			
18			

CUSTOMER'S INFORMATION BOX

CONTENTS ARE INDEPENDENT OF RIVERHAWK DOCUMENT CONTROL



215 Clinton Road
New Hartford, NY 13413
Tel: +1 315 768 4855
Fax: +1 315 768 4941
Email: info@riverhawk.com

GE DRAWING NUMBER	REV
373A4094	

Appendix C2 - Record Sheet 16 Bolt Circle

STRETCH RECORD SHEET FOR THE
LOAD COUPLING OR STEAM TURBINE TO GENERATOR

TURBINE NUMBER:

DATE:

TECHNICIAN:

SUPERVISOR:

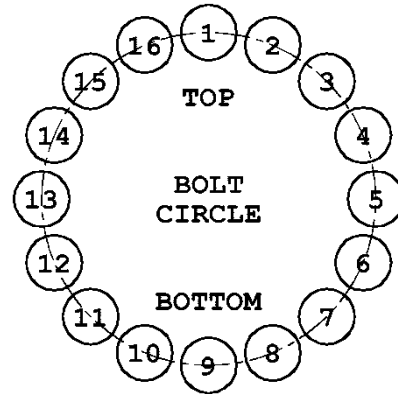

HOLE NUMBER	STARTING LENGTH	FINAL LENGTH	FINAL STRETCH
1			
9			
2			
10			
3			
11			
4			
12			
5			
13			
6			
14			
7			
15			
8			
16			

CUSTOMER'S INFORMATION BOX

CONTENTS ARE INDEPENDENT OF RIVERHAWK DOCUMENT CONTROL



215 Clinton Road
New Hartford, NY 13413
Tel: +1 315 768 4855
Fax: +1 315 768 4941
Email: info@riverhawk.com

GE DRAWING NUMBER	REV
373A4094	