



**INSTRUCTION MANUAL IM-327**  
**For Gas Turbine Tensioned**  
**Studs and Nuts**

Applicable Bolting Connections

- Fr. 7FA.05 Gas Turbine to H35 / 7FH2B Generator
- Fr. 7FA.05 Gas Turbine to Load Coupling
- Load Coupling to H35 / 7FH2B Generator
- Fr. 7F.05 Gas Turbine to H35 Generator with SSS clutch
- Fr. 7F.05 Gas Turbine to SSS clutch Input Side
- SSS clutch Output Side to H35 Generator

Applicable GE Ordering Sheet Part Numbers

106T1751P001	106T1751P007	106T1751P013	327T9308P004
106T1751P002	106T1751P008	106T1751P014	327T9308P005
106T1751P003	106T1751P009		327T9308P006
106T1751P004	106T1751P010	327T9308P001	327T9308P007
106T1751P005	106T1751P011	327T9308P002	327T9308P008
106T1751P006	106T1751P012	327T9308P003	

**CUSTOMER'S INFORMATION BOX**

CONTENTS ARE INDEPENDENT OF RIVERHAWK DOCUMENT CONTROL

<b>GE Power &amp; Water</b>		GENERAL ELECTRIC COMPANY	
<b><u>VENDOR SUPPLIED</u></b>			
GE NOT TO REVISE. GE REVISION LEVEL IS SHOWN ON THIS APPLIQUE. THIS DOCUMENT IS FILED UNDER THE GE DRAWING NUMBER. THIS DOCUMENT SHALL BE REVISED IN ITS ENTIRETY. ALL SHEETS OF THIS DOCUMENT ARE THE SAME REVISION LEVEL AS INDICATED IN THIS VENDOR SUPPLIED DRAWING APPLIQUE. MLJ: _____ OF _____			
GE SIGNATURES	DATE	GE DRAWING NUMBER	REV
CHECKED:		<b>373A4072</b>	
ISSUED:			

The Riverhawk Company reserves the right to update this document without dissemination or notice. The latest revision may be obtained by contacting Riverhawk Company or thru [www.riverhawk.com](http://www.riverhawk.com).



Repairs – Rentals  
 Field Service

215 Clinton Road  
 New Hartford, NY 13413  
 Tel: +1 315 768 4855  
 Fax: +1 315 768 4941  
 Email: [info@riverhawk.com](mailto:info@riverhawk.com)

**Table of Contents**

Section	Description	Page Number
1.0	Cautions and Safety Warnings	3
2.0	Scope and GE Part Number Cross Reference	5
3.0	Quick Checklist	7
4.0	General Preparations	12
5.0	Hardware Set Preparations	15
6.0	Stud and Nut Assembly	18
7.0	Hydraulic Tensioner Equipment Assembly	21
8.0	Assembly of Tensioner on Stud	23
9.0	Stud Tensioning	29
10.0	Thread Locking	32
11.0	Stud and Nut Removal	36
12.0	Storage Instructions	41
13.0	Frequently Asked Questions	42
14.0	Revision History	44
Appendix A1	EC Declaration of Conformity	46
Appendix A2	UKCA Declaration of Conformity	47
Appendix B1	18-Bolt Tensioning Pattern (GT-LC) Record Sheet	48
Appendix B2	16-Bolt Tensioning Pattern (LC-GEN) Record Sheet	49



215 Clinton Road  
 New Hartford, NY 13413  
 Tel: +1 315 768 4855  
 Fax: +1 315 768 4941  
 Email: info@riverhawk.com

**CUSTOMER'S INFORMATION BOX**  
 CONTENTS ARE INDEPENDENT OF RIVERHAWK DOCUMENT CONTROL

GE DRAWING NUMBER	REV
373A4072	

## 1.0 Cautions and Safety Warnings

### WARNING

**Improper tool use and the failure to follow the correct procedures are the primary root causes of tool failures and personal injuries. A lack of training or experience can lead to incorrect hardware installation or incorrect tool use. Only trained operators with careful, deliberate actions should use hydraulic tensioners. Contact Riverhawk Company with any training needs.**

### WARNING

Risk of high-pressure fluid injection. Riverhawk tools operate under high pressure. Thoroughly inspect all hoses and connections for damage or leaks prior to using this equipment.

### CAUTION

Personal injury and equipment damage can occur if the proper health and safety codes and procedures are not followed. Contact the site's health and safety office to determine all applicable safety rules and regulations.

### WARNING

The proper personal protective equipment must be worn at all times. Riverhawk recommends at a minimum, safety glasses, long sleeve shirt, hard hat, heavy work gloves, and steel toe shoes

### CAUTION

It is especially important to check the condition of the conical thread used to tension the stud. Thread damage from previous abuse can lead to failure of the stud or tensioning equipment

### CAUTION

Riverhawk recommends that the tensioner should be returned to Riverhawk for periodic inspections. Replacement of obsolete tensioners is recommended. Functional upgrades are also recommended. The Riverhawk Service Returns Coordinator should be notified 3-6 months prior to a planned outage to schedule an inspection service.

### CAUTION

Special attention must be given to the generator flanges' stud tensioning pattern. If the following steps are not followed, the generator flanges' stud installation gauge will not produce accurate measurements.



215 Clinton Road  
New Hartford, NY 13413  
Tel: +1 315 768 4855  
Fax: +1 315 768 4941  
Email: info@riverhawk.com

### CUSTOMER'S INFORMATION BOX

CONTENTS ARE INDEPENDENT OF RIVERHAWK DOCUMENT CONTROL

GE DRAWING NUMBER	REV
373A4072	

Revision K  
Page 3 of 49

**WARNING**

A damaged burst disc must be replaced with a burst disc of the same design and pressure rating. Do not substitute a damaged burst disc with a different disc type, a different pressure rating, or a foreign object.

**WARNING**

To avoid failure, ensure safety, and proper operation, the tensioner assembly must be installed on a stud in the flange before bleeding and pressurizing the tensioner. Do not use the tensioner at any pressure unless the tool is installed on a stud in a flange.

**CAUTION**

Personal injury and equipment damage can occur if the puller screw is not securely engaged with the tapered threads of the stud. Proper engagement is achieved when the puller screw is tight in the stud and the tensioner assembly is free to turn.

**WARNING**

The safety cage must be in place at all times. When the tensioner is pressurized hands must be kept out of designated areas to avoid any potential for personal injury.

**CAUTION**

Before threading the puller screw into the stud, carefully check the cleanliness of both the stud's and the puller screw's conical threads. Apply a light coat of clean turbine oil or a spray lubricant to the puller screw. This procedure will ease assembly and assure positive mating of the threads before tightening. Do not use "Never Seize" on the conical threads.

**CAUTION**

Do not tighten the nut while the tool is coming up to pressure; wait until pressure is achieved before attempting to tighten the nut with the spanner ring. If the tool is not properly installed, the tool could jump off the stud while coming up to pressure.

**CAUTION**

Do not exceed the maximum pressure marked on the tensioner. Excessive pressure can damage the stud and puller screw.

**WARNING**

**FIRE HAZARD:** DO NOT heat when puller assembly is in place. Personal injury or equipment damage may occur. Use of an Oxy-Acetylene torch is not recommended

**WARNING**

Do not use a hydraulic tensioner to remove a stud with damaged conical threads.



215 Clinton Road  
New Hartford, NY 13413  
Tel: +1 315 768 4855  
Fax: +1 315 768 4941  
Email: info@riverhawk.com

**CUSTOMER'S INFORMATION BOX**

CONTENTS ARE INDEPENDENT OF RIVERHAWK DOCUMENT CONTROL

GE DRAWING NUMBER	REV
373A4072	

## 2.0 Scope and GE Part Number Cross Reference

This document describes the procedure to be used to install the stud and nut sets supplied by the Riverhawk Company in the flanges at the Gas Turbine/Load Coupling and Load Coupling/Generator connections.

The hydraulic tooling used in this application can be identified by its ORANGE safety guard. If the safety guard is YELLOW, a different set of instructions are required. Consult the Riverhawk factory for assistance.

The various frame configurations covered in this manual are listed in Sections 2.1 through 2.7 with differences as related to connective hardware defined. Listed also are the pertinent hardware drawings (HF-xxxx). These drawings as well as tooling drawings (HT-xxxx) form part of this manual.

### 2.1 Frame 7FA.05 Gas Turbine to H35 / 7FH2B Generator

GE Part Number	Riverhawk P/N	GE VENDOC P/N
106T1751P001	HF-6281	GE 269B8773
106T1751P002	HF-6281	GE 269B8773
327T9308P001	HF-11424	GE 102B0833
327T9308P002	HF-11424	GE 102B0833

The hydraulic tooling used for installation and removal is Riverhawk HT-6282 for the gas turbine side of the load coupling and HT-6019 for the generator side of the load coupling.

These hardware drawings depict the stud and nut set for the Gas Turbine to Load Coupling (2-1/4" size, Qty 18) as well as the Load Coupling to Generator (2-3/4" size, Qty 16).

### 2.2 Frame 7FA.05 Gas Turbine to Load Coupling

GE Part Number	Riverhawk P/N	GE VENDOC P/N
106T1751P004	HF-6283	GE 269B8774
327T9308P004		

The hydraulic tooling used for installation and removal is Riverhawk HT-6282.

These hardware drawings depict the stud and nut set for the Gas Turbine to Load Coupling (2-1/4" size, Qty 18).



215 Clinton Road  
 New Hartford, NY 13413  
 Tel: +1 315 768 4855  
 Fax: +1 315 768 4941  
 Email: info@riverhawk.com

**CUSTOMER'S INFORMATION BOX**  
 CONTENTS ARE INDEPENDENT OF RIVERHAWK DOCUMENT CONTROL

GE DRAWING NUMBER	REV
373A4072	

### 2.3 Load Coupling to H35 / 7FH2B Generator

GE Part Number	Riverhawk P/N	GE VENDOC P/N
106T1751P005	HF-6284	GE 101B0627
327T9308P005		

The hydraulic tooling used for installation and removal is Riverhawk HT-6019.

These hardware drawings depict the stud and nut set for the Load Coupling to Generator (2-3/4" size, Qty 16).

### 2.4 Frame 7F.05 Gas Turbine to H35 Generator with SSS clutch

GE Part Number	Riverhawk P/N	GE VENDOC P/N
106T1751P009	HF-11378	GE 102B0827

The hydraulic tooling used for installation and removal is Riverhawk HT-6282 for the gas turbine side and HT-6019 for the generator side.

These hardware drawings depict the stud, nut, and windage plug set for the Gas Turbine to SSS Clutch Input Side (2-1/4" size, Qty 18) as well as the SSS Clutch Output Side to H35 Generator (2-3/4" size, Qty 16).

### 2.5 Frame 7F.05 Gas Turbine to SSS Clutch Input Side

GE Part Number	Riverhawk P/N	GE VENDOC P/N
106T1751P011	HF-11379	GE 102B0828

The hydraulic tooling used for installation and removal is Riverhawk HT-6282.

These hardware drawings depict the stud, nut, and windage plug set for the Gas Turbine to SSS Clutch Input Side (2-1/4" size, Qty 18).

### 2.6 SSS Clutch Output Side to H35 Generator

GE Part Number	Riverhawk P/N	GE VENDOC P/N
106T1751P012	HF-11380	GE 102B0829

The hydraulic tooling used for installation and removal is Riverhawk HT-6019.



215 Clinton Road  
 New Hartford, NY 13413  
 Tel: +1 315 768 4855  
 Fax: +1 315 768 4941  
 Email: info@riverhawk.com

**CUSTOMER'S INFORMATION BOX**  
 CONTENTS ARE INDEPENDENT OF RIVERHAWK DOCUMENT CONTROL

GE DRAWING NUMBER	REV
373A4072	

These hardware drawings depict the stud, nut, and windage plug set for the SSS Clutch Output Side to H35 Generator (2-3/4" size, Qty 16).

**2.7 Hydraulic Tooling**

GE Part Number	Riverhawk P/N	GE VENDOC P/N
106T1751P003	HT-6282	GE 269B8772
	HT-6019	GE 269B8762
	GT-6030	GE 269B8763
	AP-0532	GE 359B2502
106T1751P006	HT-6019	GE 269B8762
	GT-6030	GE 269B8763
106T1751P007	HT-6282	GE 269B8772
106T1751P008	AP-0532	GE 359B2502
106T1751P010	HT-6282	GE 269B8772
	HT-6019	GE 269B8762
	GT-6030	GE 269B8763
	AP-0532	GE 359B2502
106T1751P013	HT-6282	GE 269B8772
	AP-0532	GE 359B2502
106T1751P014	HT-6019	GE 269B8762
	GT-6030	GE 269B8763
	AP-0532	GE 359B2502
327T9308P003	HT-6282	GE 269B8772
	HT-6019	GE 269B8762
	GT-6030	GE 269B8763
	AP-0532	GE 359B2502
327T9308P006	HT-6019	GE 269B8762
	GT-6030	GE 269B8763
327T9308P007	HT-6282	GE 269B8772
327T9308P008	AP-0532	GE 359B2502



215 Clinton Road  
 New Hartford, NY 13413  
 Tel: +1 315 768 4855  
 Fax: +1 315 768 4941  
 Email: info@riverhawk.com

**CUSTOMER'S INFORMATION BOX**  
 CONTENTS ARE INDEPENDENT OF RIVERHAWK DOCUMENT CONTROL

GE DRAWING NUMBER	REV
373A4072	

### 3.0 Quick Checklist

The following checklist is intended as a summary of the steps needed to use the Riverhawk-supplied equipment. New personnel or those experienced personnel who have not used the Riverhawk equipment recently are encouraged to read the entire manual.

#### EQUIPMENT INSPECTION

- Check oil level in hydraulic pump.
- Check air pressure at 80psi [5.5 bar] minimum. (For air-driven pumps)
- Check hydraulic hose for damage.
- Test pump.
- Inspect tensioner for any damage.

#### NUT AND STUD PREPARATION

- Inspect studs, nuts, and windage plugs (if included in the hardware set) for any damage.
- Clean the studs, nuts, and windage plugs.
- Measure stud lengths for the gas turbine flange studs.
- Lubricate the stud's threads with clean turbine oil or spray lubricant. Lubricate the nut's threads and nut face with clean turbine oil or spray lubricant.
- Install studs and nuts (off-center) into the flange.
- Set stick-out dimension on the load coupling or SSS Clutch side of the flange.
- With Allen wrench in backside of stud, firmly seat backside nut using spanner ring and pin wrench.
- Verify stick-out measurement (**VERY IMPORTANT**)



215 Clinton Road  
 New Hartford, NY 13413  
 Tel: +1 315 768 4855  
 Fax: +1 315 768 4941  
 Email: info@riverhawk.com

CUSTOMER'S INFORMATION BOX  
 CONTENTS ARE INDEPENDENT OF RIVERHAWK DOCUMENT CONTROL

GE DRAWING NUMBER	REV
373A4072	

- Measure and record starting stud installation gage readings. **(Load Coupling/Generator flange and SSS Clutch Output/Generator flange Only). Follow Generator Stud Tensioning Pattern from section 8.2**

**TENSIONING (Bolt Installation)**

- Check tensioner drawing for correct parts and part numbers.
- Apply a light coat of clean turbine oil or spray lubricant to the puller screw. **DO NOT USE “NEVER SEIZE” ON THE CONICAL THREADS.**
- Install the retention screws into the adjacent studs on either side of the stud to be tensioned. **(Load Coupling/Generator flange and SSS Clutch Output/Generator flange Only).**
- Install the spanner ring onto the nut.
- Thread the puller screw into the stud.
- Insert an Allen wrench into the back side of the stud.
- Insert another Allen wrench into the puller screw. While holding the stud still, tighten the puller screw until hand tight and then loosen the puller screw 1/2 of a turn. Retighten the puller screw and leave tight. **DO NOT BACK OFF PULLER SCREW.**
- Slide the correct foot over the puller stud and orientate the foot into position. *Note: the correct foot for the load coupling/generator flange and SSS clutch Output/generator flange is marked “Generator End”.*
- Thread the tensioner onto puller screw until it stops. There should be a 1/16” to 3/16” gap between the foot and tensioner.
- Place the guard over the tensioner and position guide pin into the hole in the backside of the stud. **(Gas Turbine/Load Coupling and Gas Turbine/SSS Clutch Input Side Only).**
- Place the guard over tensioner and position the guard’s pocketed slots into retention screws. **(Load Coupling/Generator flange and SSS Clutch Output/Generator flange Only).**
- Tighten the guard’s knurled interlock fitting by hand until it presses firmly against tensioner (no gap).



215 Clinton Road  
 New Hartford, NY 13413  
 Tel: +1 315 768 4855  
 Fax: +1 315 768 4941  
 Email: info@riverhawk.com

**CUSTOMER'S INFORMATION BOX**  
 CONTENTS ARE INDEPENDENT OF RIVERHAWK DOCUMENT CONTROL

GE DRAWING NUMBER	REV
373A4072	

- The retention screws must be inside the guard's pocketed slots. **(Load Coupling/Generator flange and SSS Clutch Output/Generator flange Only).**
- Push the center of the interlock fitting towards the tensioner while pulling back on the fitting's pull tabs until it locks onto the tensioner and release the pull tabs.
- Install the backside guard to cover stud to be tensioned. **(Load Coupling/Generator flange and SSS Clutch Output/Generator flange Only).**
- Connect the hydraulic pump to the tensioner and tension to 50%. Consult manual for correct pressure.
- Use the pin wrench to turn the spanner ring to firmly tighten nut with 20 ft·lbs [27 N·m] of torque.
- Release pressure and allow the tensioner to fully retract.
- Disconnect the hose and release the interlock fitting by pushing the center of the interlock fitting towards the tensioner while pulling back on the fitting's pull tabs.
- Remove the backside guard. **(Load Coupling/Generator flange and SSS Clutch Output/Generator flange Only).**
- Loosen the knurled interlock fitting and remove the guard.
- Unscrew the tensioner from the puller screw.
- Remove the foot, puller screw, spanner ring, and in the case of the generator side the retention screws.
- Move to the next stud in the pattern. Tension all studs to 50% before proceeding to final pressure.
- Repeat above steps at final pressure.
- Measure final stud length and record on stretch datasheets. Calculate final stretch measurement. The load coupling/generator flange and SSS Clutch Output flange must use GT-6030 gauge to verify installation.
- Torque the nuts' set screws.



215 Clinton Road  
New Hartford, NY 13413  
Tel: +1 315 768 4855  
Fax: +1 315 768 4941  
Email: info@riverhawk.com

CUSTOMER'S INFORMATION BOX  
CONTENTS ARE INDEPENDENT OF RIVERHAWK DOCUMENT CONTROL

GE DRAWING NUMBER	REV
373A4072	

- Install the windage plugs (if included in the hardware set) and torque their set screws.

**DETENSIONING (Stud Removal)**

- If present, loosen the windage plugs' set screws and remove the windage plugs from the studs.
- Loosen nuts' set screws
- Inspect and clean studs' conical threads. **Do not continue until ALL debris is removed from the threads!** See instruction manual IM-220. **Do not try to use the tensioner to remove a damaged stud!**
- Apply a light coat of clean turbine oil or spray lubricant to the puller screw. **DO NOT USE "NEVER SEIZE" ON THE CONICAL THREADS.**
- Install the retention screws into the adjacent studs on either side of the stud to be tensioned. **(Load Coupling/Generator flange and SSS Clutch Output/Generator flange Only).**
- Install the spanner ring onto the nut.
- Thread the puller screw into the stud.
- Insert an Allen wrench into the back side of the stud.
- Insert another Allen wrench into the puller screw. While holding the stud still, tighten the puller screw until hand tight and then loosen the puller screw 1/2 of a turn. Retighten the puller screw and leave tight. **DO NOT BACK OFF PULLER SCREW.**
- Slide the correct foot over the puller stud and orientate the foot into position. *Note: the correct foot for the generator end is marked "Generator End"*
- Thread the tensioner onto puller screw until it stops. There should be a 1/16" to 3/16" gap between the foot and tensioner.
- Place the guard over the tensioner and position guide pin into the hole in the backside of the stud. **(Load Coupling/Generator flange and SSS Clutch Output/Generator flange Only).**



215 Clinton Road  
 New Hartford, NY 13413  
 Tel: +1 315 768 4855  
 Fax: +1 315 768 4941  
 Email: info@riverhawk.com

**CUSTOMER'S INFORMATION BOX**  
 CONTENTS ARE INDEPENDENT OF RIVERHAWK DOCUMENT CONTROL

GE DRAWING NUMBER	REV
373A4072	

- Place the guard over tensioner and position the guard's pocketed slots into retention screws. **(Load Coupling/Generator flange and SSS Clutch Output/Generator flange Only).**
- Tighten the guard's knurled interlock fitting by hand until it presses firmly against tensioner (no gap).
- The retention screws must be inside the guard's pocketed slots. **(Load Coupling/Generator flange and SSS Clutch Output/Generator flange Only).**
- Push the center of the interlock fitting towards the tensioner while pulling back on the fitting's pull tabs until it locks onto the tensioner and release the pull tabs.
- Install the backside guard to cover stud to be tensioned. **(Load Coupling/Generator flange and SSS Clutch Output/Generator flange Only).**
- Connect the hydraulic pump to the tensioner and tension to final pressure. Consult manual for correct pressure.
- Loosen nut with the spanner ring and pin wrench.
- Release pressure and allow the tensioner to fully retract.
- Disconnect the hose and release the interlock fitting by pushing the center of the interlock fitting towards the tensioner while pulling back on the fitting's pull tabs.
- Remove the backside guard. **(Load Coupling/Generator flange and SSS Clutch Output/Generator flange Only).**
- Loosen the knurled interlock fitting and remove the guard.
- Unscrew the tensioner from the puller screw.
- Remove the foot, puller screw, spanner ring, and in the case of the generator side the retention screws. It may be necessary to insert an Allen wrench into the backside of the stud to remove the puller screw.
- Move to next stud in pattern



215 Clinton Road  
 New Hartford, NY 13413  
 Tel: +1 315 768 4855  
 Fax: +1 315 768 4941  
 Email: info@riverhawk.com

**CUSTOMER'S INFORMATION BOX**  
 CONTENTS ARE INDEPENDENT OF RIVERHAWK DOCUMENT CONTROL

GE DRAWING NUMBER	REV
373A4072	

## 4.0 General Preparations

Read and understand all instructions before installing and tensioning studs.

Operators should be trained or have previous experience using Riverhawk tensioning equipment. Training will minimize the chance of improper use of the equipment.

The hydraulic tooling including the hydraulic hoses should be inspected prior to use. Inspection guidelines are listed in the following sub-sections.

This equipment produces very high hydraulic pressures and very high forces. Operators must exercise caution and wear the appropriate personal protective equipment when handling and operating the hydraulic tooling.

High-pressure oil from the hydraulic pump pressurizes the tensioner which generates a very large force that actually stretches the stud. As the stud is stretched the nut lifts off the flange. The nut is then turned by hand using the supplied spanner ring. Once the nut is tight against the flange, the pressure in the tensioner is released. The hardware is now clamping the flange together.

### 4.1 Machine Preparation

The flange to be tensioned must be fully closed prior to positioning of studs in the flanges. Turning the shafts is not required, but may be useful. Also, it will be advantageous to remove as many obstructions as possible from the flange area, such as speed probes, shipping plates, and conduit.

### 4.2 Hardware – Balance

The studs are supplied in component balanced sets. A stud can be exchanged with another stud in its set without affected the overall balance of the equipment. Do not exchange a stud from one set with another stud from a different set. When shipped from Riverhawk, the studs are not assigned to any specific hole in the load coupling flange; this is optional and can be done at the installation site. The set size is determined by the relevant GE order drawing (see section 2.0).

The nuts are supplied in component balanced sets. A nut can be exchanged with another nut in its set without affected the overall balance of the equipment. Do not exchange a nut from one set with another nut from a different set. When shipped from Riverhawk, the nuts are not assigned to any specific hole in the load coupling flange; this is optional and can be done at the installation site. The set size is determined by the relevant GE order drawing (see section 2.0).



215 Clinton Road  
New Hartford, NY 13413  
Tel: +1 315 768 4855  
Fax: +1 315 768 4941  
Email: info@riverhawk.com

**CUSTOMER'S INFORMATION BOX**  
CONTENTS ARE INDEPENDENT OF RIVERHAWK DOCUMENT CONTROL

GE DRAWING NUMBER	REV
373A4072	

Revision K  
Page 13 of 49



HT-6019 Hydraulic Tensioner, 2-3/4"  
**(Load Coupling/Generator flange and SSS Clutch  
Output/Generator flange Only)**  
(reference GE VENDOC 269B8762)

Stud Stretch Measuring Gauge: GT-6030 Stretch Gauge  
**(Load Coupling/Generator flange and SSS Clutch  
Output/Generator flange Only)**  
(reference GE VENDOC 269B8763)

Hydraulic Pump Kit: AP-0532 Air-Operated Hydraulic Pump  
(recommended)  
(reference GE VENDOC 359B2502)

**CAUTION**

**Riverhawk recommends that the tensioners be returned to Riverhawk for periodic inspections. Replacement of obsolete tensioners is recommended. Functional upgrades are also recommended. The Riverhawk Service Returns Coordinator should be notified 3-6 months prior to a planned outage to schedule an inspection service.**

**5.0 Hardware Set Preparations**

**5.1 Nut Preparation**

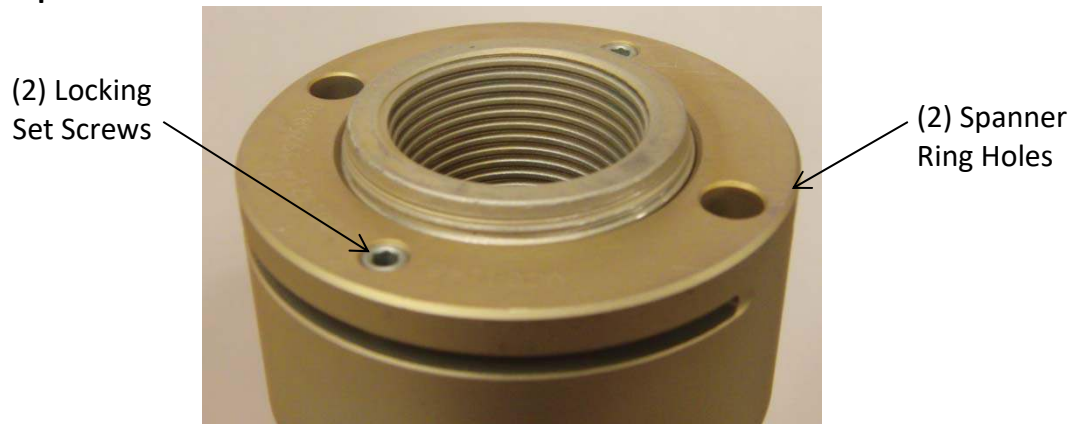

**Picture 5A - Riverhawk Locknut**



215 Clinton Road  
New Hartford, NY 13413  
Tel: +1 315 768 4855  
Fax: +1 315 768 4941  
Email: info@riverhawk.com

CUSTOMER'S INFORMATION BOX  
CONTENTS ARE INDEPENDENT OF RIVERHAWK DOCUMENT CONTROL

GE DRAWING NUMBER	REV
373A4072	

Revision K  
Page 15 of 49

If there is any visible damage on a nut, do not use the nut and contact the Riverhawk Company for a replacement nut. Please be prepared to supply the turbine number, weight certification, and digital photographs for evaluation.

### 5.1.1 Nut Cleaning - New Installations

For new installations, the nuts should come sealed from the factory and will need no cleaning.

### 5.1.2 Nut Cleaning - Old Installations

Previously installed nuts require cleaning as follows: Wire brush using a petroleum-based solvent to remove any foreign material on the external surfaces and threads.

## 5.2 Stud Preparation

Check the stud for any visible damage. If there is any visible damage, do not use the stud and contact the Riverhawk Company for a replacement stud. Please be prepared to supply the turbine number, weight certification, and digital photographs for evaluation.

### CAUTION

**It is especially important to check the condition of the conical thread used to tension the stud. Thread damage from previous abuse can lead to failure of the stud or tensioning equipment.**

The conical threads of each stud must be clean of grit and dirt before installation or removal. This ensures the proper seating of the puller screw.

### 5.2.1 Stud Cleaning - New Installations

For new installations, the studs should come sealed from the factory and will need no cleaning.

### 5.2.2 Stud Cleaning - Old Installations

Previously installed studs may require cleaning. Clean conical threads should have a bright and shiny appearance.

If cleaning is required, follow these steps:

1. Blow out the threads with compressed air to remove loose debris and dry conical threads. Do not apply a solvent or other cleaning solution to the threads as this may chemically attack the stud.



215 Clinton Road  
New Hartford, NY 13413  
Tel: +1 315 768 4855  
Fax: +1 315 768 4941  
Email: info@riverhawk.com

### CUSTOMER'S INFORMATION BOX

CONTENTS ARE INDEPENDENT OF RIVERHAWK DOCUMENT CONTROL

GE DRAWING NUMBER	REV
373A4072	

Revision K  
Page 16 of 49

2. Use Stud Cleaning Kit, GT-4253 or a similar 1" diameter Brass power brush.



Picture 5B - Brass Power Brush

3. Insert the brush into an electric drill and set drill to run in a counterclockwise direction at high speed.
4. Work the drill in a circular motion while moving the brush in and out to clean all of the threads. Try not to hold the brush in one place too long, so as not to remove the stud's protective coating.
5. Blow out the threads with compressed air to remove loosened debris.
6. Visually inspect threads for cleanliness. Threads should be bright and shiny.
7. Repeat if any dirt can be seen in the threads.
8. Inspect threads for any damage that may have been caused by previous installation.
9. Do **not** apply "Never Seize" to the stud's threads.
10. Finish the cleaning process by rinsing in a volatile solvent such as acetone and allow the stud to dry.

### 5.3 Stud Length Measurement

#### 5.3.1 Gas Turbine Flange 2-1/4" [58mm] Studs

Measure and record the initial lengths of the gas turbine flange studs. The following suggestions will improve your results.

- **Plan to start and finish any flange in the same day.**
- **Studs and flange must be at the same temperature.**
- **Number each stud with a marker for later stretch measurement tracking.**
- **Mark the location of measurement on stud end with a permanent marker.**
- **Measure each stud to nearest 0.001 inch (.01 mm).**



215 Clinton Road  
New Hartford, NY 13413  
Tel: +1 315 768 4855  
Fax: +1 315 768 4941  
Email: info@riverhawk.com

CUSTOMER'S INFORMATION BOX  
CONTENTS ARE INDEPENDENT OF RIVERHAWK DOCUMENT CONTROL

GE DRAWING NUMBER	REV
373A4072	

Revision K  
Page 17 of 49

- Record each measurement on the supplied record sheets.
- Do not allow the measuring instruments to sit in the sun.
- The same person should make all measurements.

### 5.3.2 Generator Flange 2-3/4" [71mm] Studs

The generator flange studs do not have to have their lengths measured. The generator flange studs require the use of a special stud installation gauge that measures the distance from the stud end to the flange face.

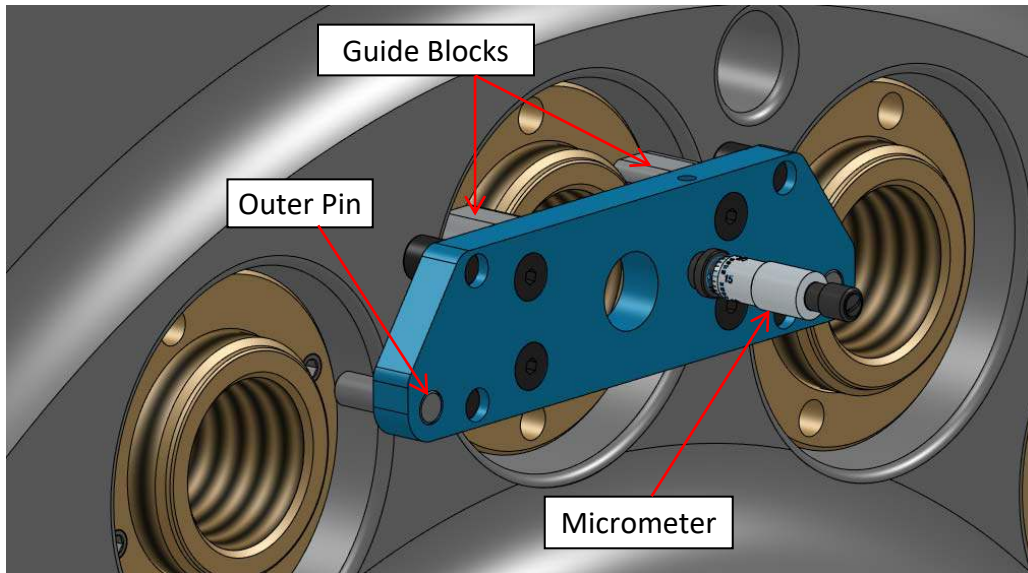

Picture 5C – Stud Installation Gauge

Refer to the GT-6030 Stud Installation Gage instruction manual, IM-309. The latest revision may be obtained by contacting Riverhawk Company or thru [www.riverhawk.com](http://www.riverhawk.com).

## 6.0 Stud and Nut Assembly

Refer to the hardware assembly drawing (HF-xxxx) listed in Section 2.0 of the manual.

1. Assemble the cylindrical nut to the internal, conical thread end of the stud.
2. Lubricate the stud's threads with clean turbine oil or spray lubricant.
3. Lubricate the nut's threads and nut face with clean turbine oil or spray lubricant.



215 Clinton Road  
 New Hartford, NY 13413  
 Tel: +1 315 768 4855  
 Fax: +1 315 768 4941  
 Email: [info@riverhawk.com](mailto:info@riverhawk.com)

**CUSTOMER'S INFORMATION BOX**  
 CONTENTS ARE INDEPENDENT OF RIVERHAWK DOCUMENT CONTROL

GE DRAWING NUMBER	REV
373A4072	

Revision K  
 Page 18 of 49

- Slide the stud and cylindrical nut assembly into the flange as shown in Figures 6A and 6B.

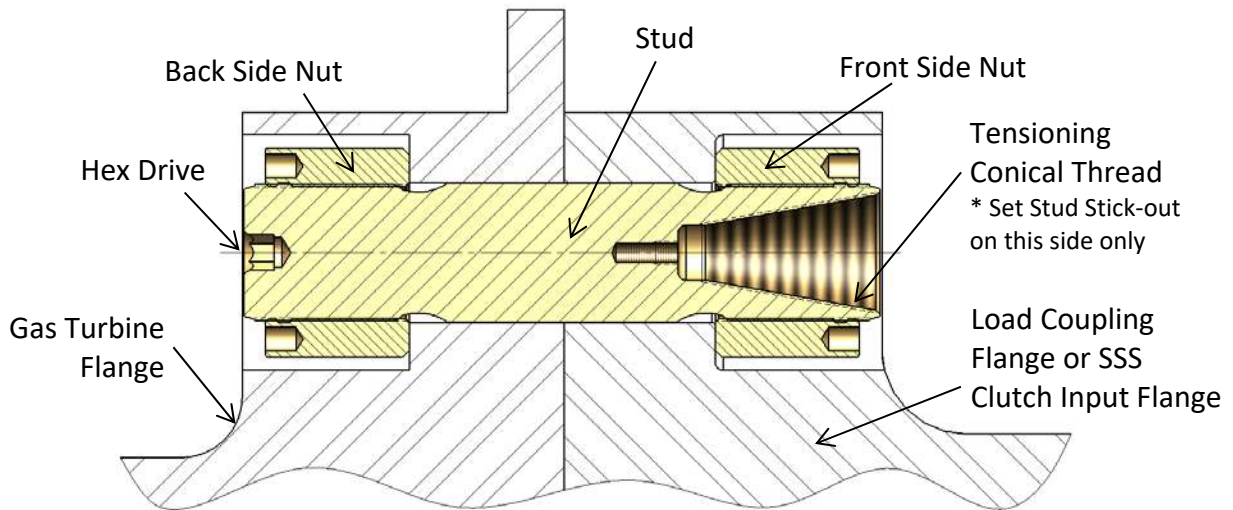

**Figure 6A** – Cross-section View of Gas Turbine to Load Coupling Flange or Gas Turbine to SSS Clutch Input Flange Bolted Connection

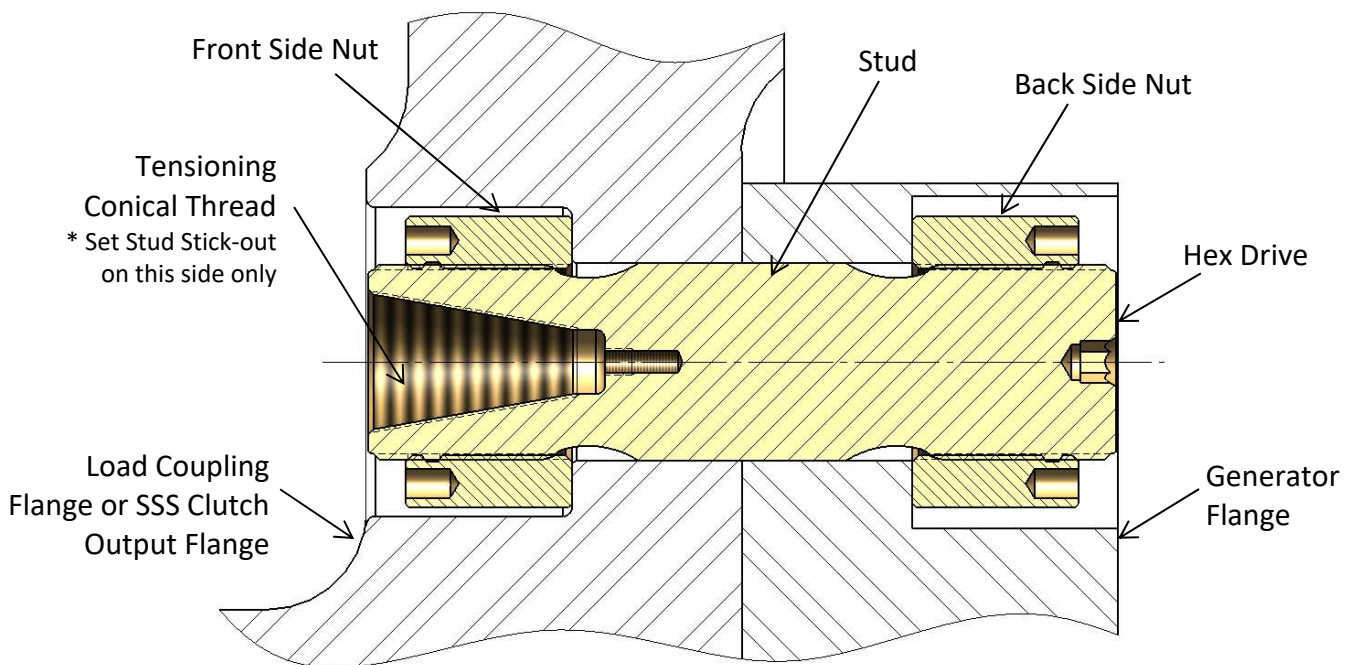

**Figure 6B** – Cross-section View of Load Coupling to Generator Flange or SSS Clutch Output to Generator Flange Bolted Connection

**CUSTOMER'S INFORMATION BOX**

CONTENTS ARE INDEPENDENT OF RIVERHAWK DOCUMENT CONTROL

GE DRAWING NUMBER	REV
373A4072	



215 Clinton Road  
 New Hartford, NY 13413  
 Tel: +1 315 768 4855  
 Fax: +1 315 768 4941  
 Email: info@riverhawk.com

5. Install the other nut on the backside.
6. Adjust the nut/stud assembly so that the stud protrudes (or sticks out) from the face of the cylindrical nut the distance specified on the hardware drawing (HF-xxxx). **SETTING THIS PROTRUSION OF STUD TO NUT IS CRITICAL FOR PROPER TENSIONER OPERATION.** A metal stick-out gage is provided with the tensioner to assist the operator in setting the protrusion dimension.



**Picture 6C** – Use of Stick-Out Gage on the Gas Turbine side of the Flange Joint



**Picture 6D** – Use of Drop Gage to measure stick-out

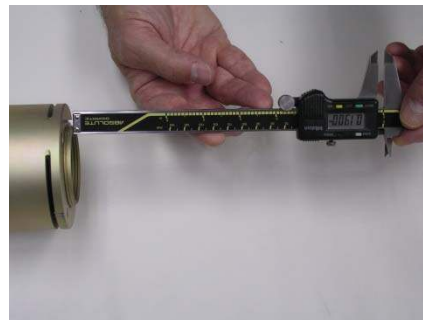

**Picture 6E** – Use of Calipers to measure stick-out

7. With Allen wrench in backside of stud, firmly seat backside nut using spanner ring and pin wrench.
8. Recheck the stud stick-out length. If the stick-out length does not match the hardware drawing, adjust the nuts as necessary.



215 Clinton Road  
 New Hartford, NY 13413  
 Tel: +1 315 768 4855  
 Fax: +1 315 768 4941  
 Email: info@riverhawk.com

CUSTOMER'S INFORMATION BOX  
 CONTENTS ARE INDEPENDENT OF RIVERHAWK DOCUMENT CONTROL

GE DRAWING NUMBER	REV
373A4072	

## 7.0 Hydraulic Tensioner Equipment Assembly

### 7.1 Hydraulic Equipment Inspection

#### 7.1.1 Hydraulic Tensioner Inspection

#### CAUTION

**Riverhawk recommends that the tensioner be returned to Riverhawk for periodic inspections. Replacement of obsolete tensioners is recommended. Functional upgrades are also recommended. The Riverhawk Service Returns Coordinator should be notified 3-6 months prior to a planned outage to schedule an inspection service.**

This tensioner does not require bleeding. See section 8.3

#### WARNING

**To avoid failure, ensure safety, and proper operation, the tensioner assembly must be installed on a stud in the flange before bleeding and pressurizing the tensioner. Do not use the tensioner at any pressure unless the tool is installed on a stud in a flange.**

Clean puller screw and check for any debris and dents.

Inspect the tensioner guard for any signs of damage including cracked welds. Any guards modified in the field should be replaced. Bent guards should be replaced. Also, be sure the rubber pad is in place on the back side guard, if missing, replace.

Inspect the outside of the tensioner for discoloration patterns that may indicate submersion and internal damage.

Perform an inventory of the loose equipment supplied with the tensioner. An inventory list is provided on the tensioner's technical drawing (Riverhawk HT-xxxx listed in section 2.0 and 4.5). Replacement parts are available from Riverhawk.

#### 7.1.1.1 Hydraulic Tensioner's Burst Disc Replacement

The hydraulic tensioner's burst disc is a key element in the overall safe use of the hydraulic tensioner. The burst disc's location is shown on the tensioner's technical drawing (Riverhawk HT-xxxx listed in section 2.0 and 4.5).



215 Clinton Road  
New Hartford, NY 13413  
Tel: +1 315 768 4855  
Fax: +1 315 768 4941  
Email: info@riverhawk.com

#### CUSTOMER'S INFORMATION BOX

CONTENTS ARE INDEPENDENT OF RIVERHAWK DOCUMENT CONTROL

GE DRAWING NUMBER	REV
373A4072	

Revision K  
Page 21 of 49

Each tensioner is shipped from our factory with one burst disc already installed in the tensioner and with another spare disc for field replacement. Extra burst discs are available from Riverhawk for replacement purposes.

To replace a damaged burst disc:

1. Remove the hydraulic port's dispersion nut, compression ring, and damaged burst disc.
2. Discard the damaged burst disc.
3. Clean the dispersion nut, compression ring, new burst disc, and the hydraulic port with a solvent to ensure a dirt-free installation.
4. Reassemble new burst disc, compression ring, and dispersion nut into the same hydraulic port.

**Warning**

**A damaged burst disc must be replaced with a burst disc of the same design and pressure rating. Do not substitute a damaged burst disc with a different disc type, a different pressure rating, or a dissimilar object.**

**7.1.2 Hydraulic Pump Kit Inspection**

Refer to the Hydraulic Pump Kit Instruction Manual, IM-293 (GE VENDOC 373A4058). The latest revision may be obtained by contacting Riverhawk Company or thru [www.riverhawk.com](http://www.riverhawk.com).

**7.2 Hydraulic Fittings**

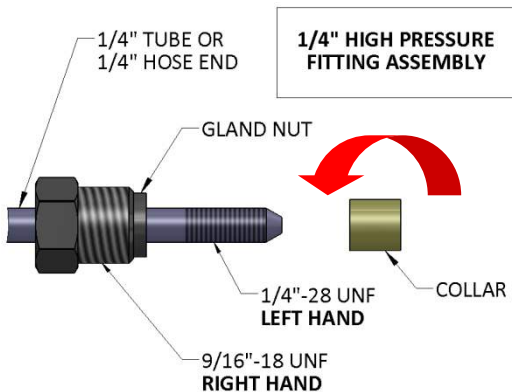

Illustration 1

Riverhawk hydraulic pumps use a 1/4" High Pressure port to connect its hydraulic hoses. The hose connector is made from a three-piece assembly: a gland nut, a collar, and a 1/4" tube or 1/4" hose end. (See Illustration 1)

To assembly the fitting, slide the gland nut over the 1/4" tube or 1/4" hose end. Turn the collar counter-clockwise (**left hand** thread) on to the tube or hose end as shown in Illustration 1.

CUSTOMER'S INFORMATION BOX

CONTENTS ARE INDEPENDENT OF RIVERHAWK DOCUMENT CONTROL

GE DRAWING NUMBER	REV
373A4072	



215 Clinton Road  
 New Hartford, NY 13413  
 Tel: +1 315 768 4855  
 Fax: +1 315 768 4941  
 Email: [info@riverhawk.com](mailto:info@riverhawk.com)

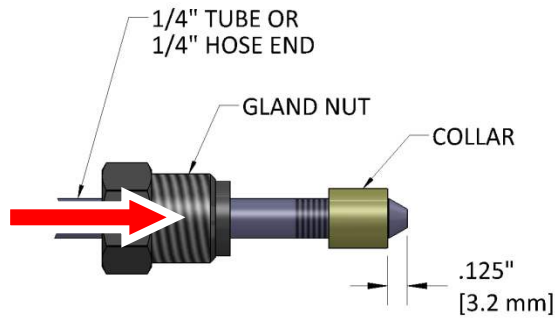

Illustration 2

The collar should be placed .125" (3.2 mm) from the tip of the cone. (See Illustration 2) It may be necessary to adjust this collar with a set of vise-grip pliers. Be careful to not strip the threads off the tube or hose end.

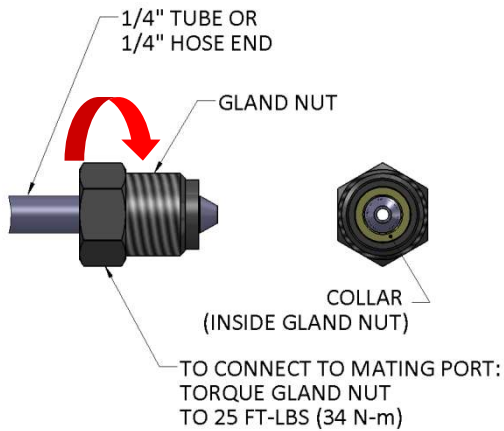

Illustration 3

Slide the gland nut down over the collar. (See Illustration 3) Insert the 1/4" tube or 1/4" hose end into the tensioner's quick coupler. While firmly holding the tube or hose end to stop it from rotating, turn the gland nut clockwise (**right hand** thread) and torque the gland nut to 25 FT-LBS (34 N-m).

Tips:

- Make sure all parts are clean and free from debris.
- Protect the cone on the end of the 1/4" tube or 1/4" hose end from scratches as this is the sealing surface.
- Replace red plastic caps when finished to protect the threads and cone.

## 8.0 Assembly of Tensioner on a Stud

The tensioner used in this application can be identified by its ORANGE safety guard. If the tensioner's safety guard is YELLOW, a different set of instructions are required. Consult the Riverhawk factory for assistance.

### 8.1 Handling of the Tensioner

The tensioner used in this application is designed to require no special lifting instructions. Do not drop any part of the tensioner on the operator or other nearby personnel.



215 Clinton Road  
 New Hartford, NY 13413  
 Tel: +1 315 768 4855  
 Fax: +1 315 768 4941  
 Email: info@riverhawk.com

CUSTOMER'S INFORMATION BOX  
 CONTENTS ARE INDEPENDENT OF RIVERHAWK DOCUMENT CONTROL

GE DRAWING NUMBER	REV
373A4072	

## 8.2 Generator Flange Stud Tensioning Pattern

### CAUTION

**Special attention must be given to the generator flanges' stud tensioning pattern. If the following steps are not followed, the generator flanges' stud installation gage will not produce accurate measurements.**

1. Following the tensioning instructions from the next section, select 4 studs that are evenly spaced around the flange.
2. Tensioning these four studs to 50% of the final pressure. This is to ensure the flange is fully closed.
3. Check the remaining studs for loosening and verify their stick-out dimensions.
4. Measure and record the remaining studs initial gauge measurement with the Stud Installation Gage, GT-6030.
5. Select another 4 studs that are also evenly spaced around the flange and tension these studs to 50% of the final pressure.
6. Remove the tension from the original 4 studs.
7. Check the original studs for loosening and verify their stick-out dimensions.
8. Measure and record the original studs initial gauge measurement with the Stud Installation Gage, GT-6030.
9. Continue with tensioning all of the studs to 50% of their final pressure.

The purpose of this procedure is to ensure accurate measurements with the Stud Installation Gage. If the flange is not completely closed and the initial measurements are wrong, the final gauge reading will not be correct.

## 8.3 Kit Assembly

Connect the hydraulic hose from the hydraulic pump to the tensioner.

Refer to the hardware assembly drawing (HF-xxxx) listed in Section 2.0 of this manual and the tensioner assembly drawing (HT-xxxx) listed in Section 4.5 of this manual to determine how the tensioner must be assembled on the load coupling for its correct operation.



215 Clinton Road  
 New Hartford, NY 13413  
 Tel: +1 315 768 4855  
 Fax: +1 315 768 4941  
 Email: info@riverhawk.com

CUSTOMER'S INFORMATION BOX  
 CONTENTS ARE INDEPENDENT OF RIVERHAWK DOCUMENT CONTROL

GE DRAWING NUMBER	REV
373A4072	

Revision K  
 Page 24 of 49

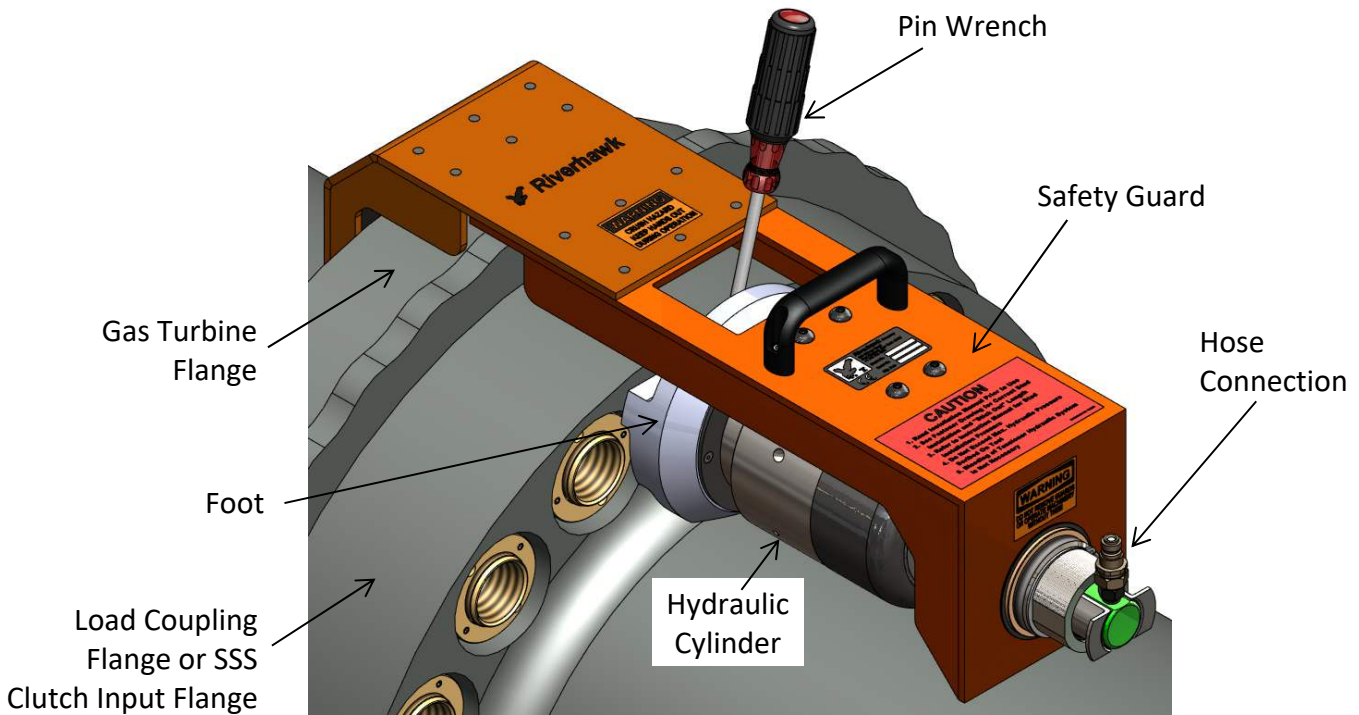

Picture 8A – Features of the Hydraulic Tensioner HT-6282 (turbine end only)

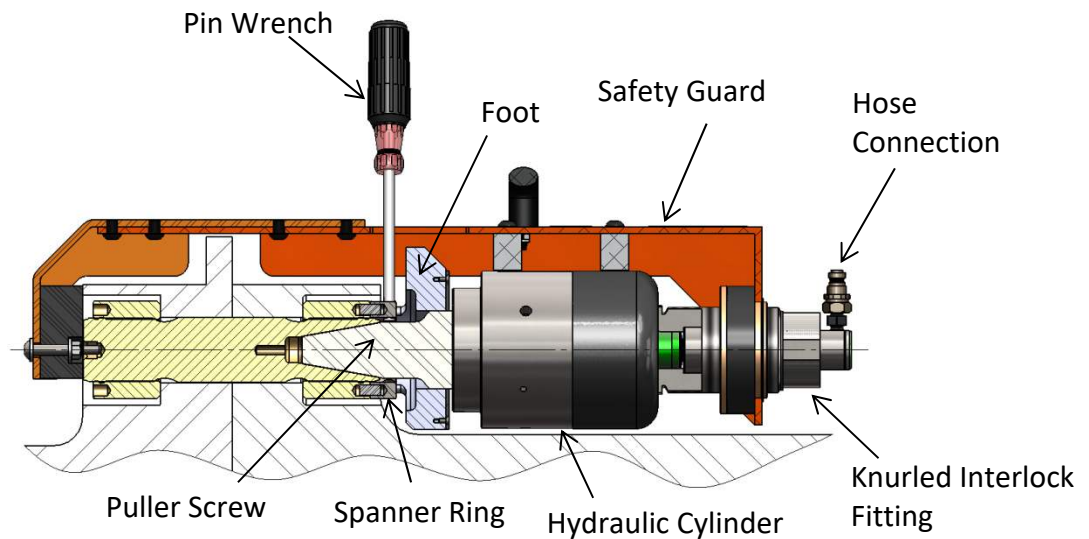

Figure 8B – Cutaway view of Hydraulic Tensioner HT-6282 (turbine end only)



215 Clinton Road  
New Hartford, NY 13413  
Tel: +1 315 768 4855  
Fax: +1 315 768 4941  
Email: info@riverhawk.com

**CUSTOMER'S INFORMATION BOX**  
CONTENTS ARE INDEPENDENT OF RIVERHAWK DOCUMENT CONTROL

GE DRAWING NUMBER	REV
373A4072	

Revision K  
Page 25 of 49

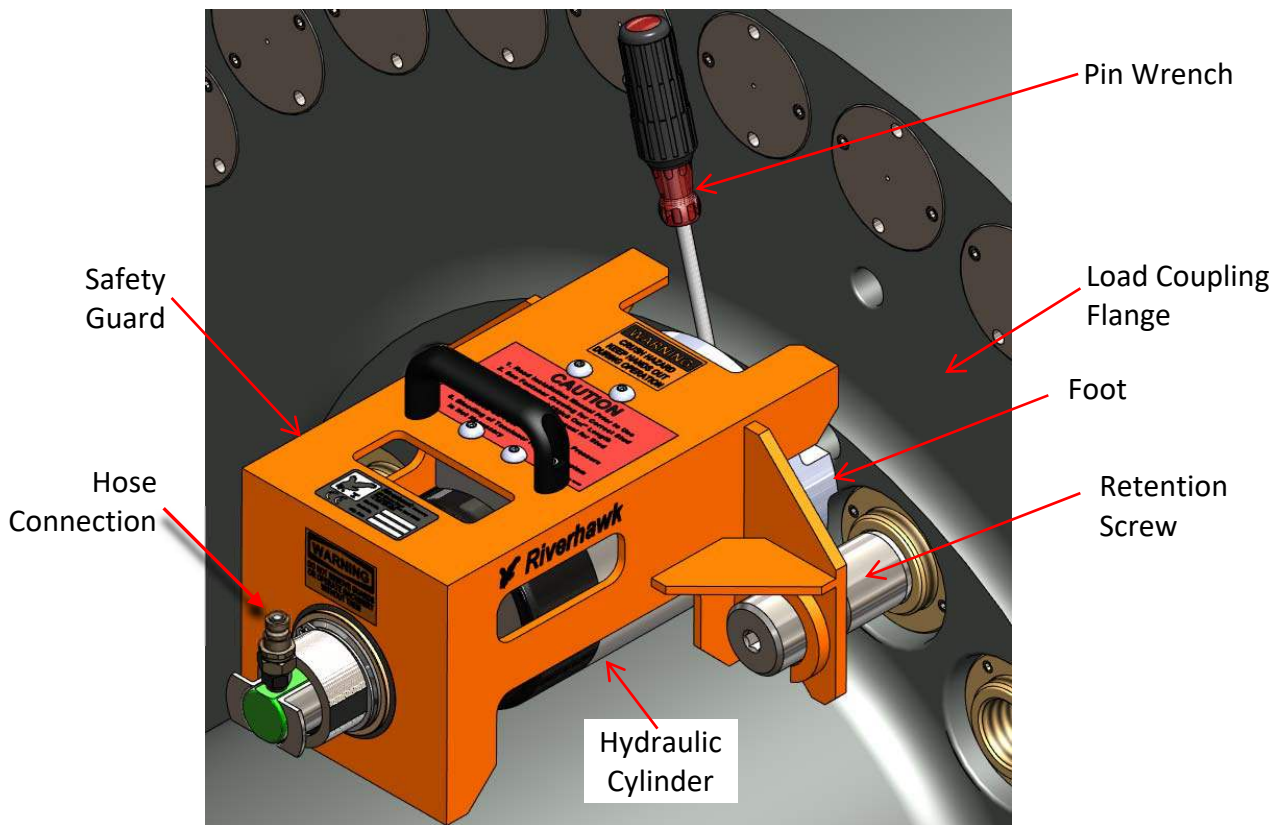

**Picture 8C** – Features of the Hydraulic Tensioner HT-6019 (generator end only).  
Shown on a load coupling/generator flange.

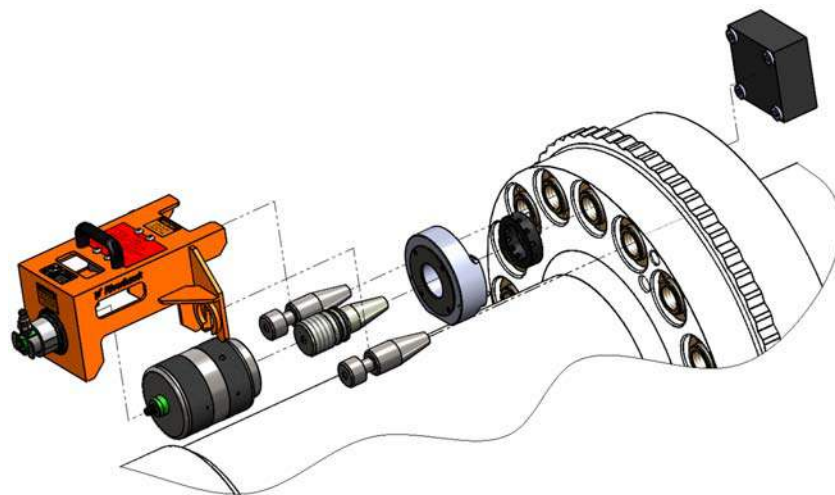

**Picture 8D** – Features of the Hydraulic Tensioner HT-6019 (generator end only).  
Shown on a SSS clutch output side/generator flange.

**CUSTOMER'S INFORMATION BOX**  
CONTENTS ARE INDEPENDENT OF RIVERHAWK DOCUMENT CONTROL

GE DRAWING NUMBER	REV
373A4072	



215 Clinton Road  
New Hartford, NY 13413  
Tel: +1 315 768 4855  
Fax: +1 315 768 4941  
Email: info@riverhawk.com

Revision K  
Page 26 of 49

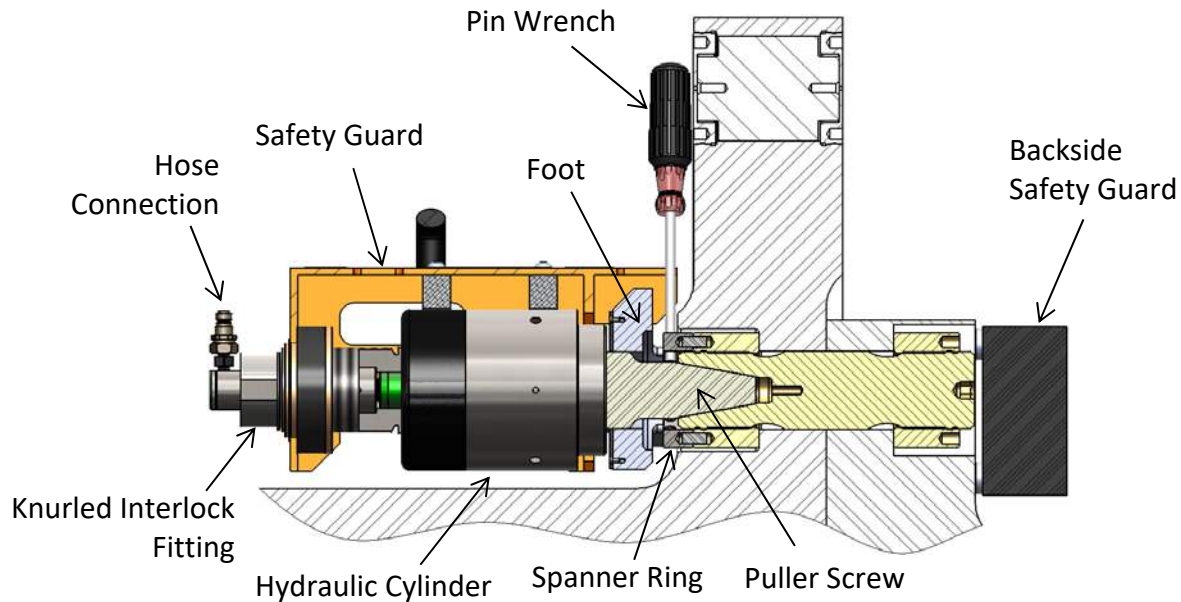

**Figure 8E** – Cutaway view of Hydraulic Tensioner HT-6019 (generator end only)  
Shown on a load coupling/generator flange.

**Note:** Before threading the puller screw into the stud, carefully check the cleanliness of both the stud's and the puller screw's conical threads. Apply a light coat of clean turbine oil or a spray lubricant to the puller screw. Do not use "Never Seize" on the conical threads. This procedure will ease assembly and assure positive mating of the threads before tightening.

Assembly sequence is as follows:

1. Open the hydraulic return valve on the pump to allow hydraulic fluid to be pushed back from the puller tool into the pump reservoir. (This is automatic on the air-operated hydraulic pump).
2. Thread the retention screws into the adjacent studs on either side of the stud to be tensioned until hand tight. **(Load Coupling/Generator flange and SSS Clutch Output/Generator flange Tensioner Only)**
3. Place the spanner ring on the nut.
4. Insert the puller screw release tape per Riverhawk manual IM-336.
5. Insert the puller screw into the tapered thread of the stud and hand tighten. **Be sure not to cross-thread the puller screw.**



215 Clinton Road  
New Hartford, NY 13413  
Tel: +1 315 768 4855  
Fax: +1 315 768 4941  
Email: info@riverhawk.com

CUSTOMER'S INFORMATION BOX  
CONTENTS ARE INDEPENDENT OF RIVERHAWK DOCUMENT CONTROL

GE DRAWING NUMBER	REV
373A4072	

Revision K  
Page 27 of 49

6. Using an Allen wrench, tighten the puller screw and then back off the puller screw 1/2 a turn. Retighten the puller screw by hand until it is fully inserted. **DO NOT BACK OFF THE PULLER SCREW.**
7. Place the correct foot over the puller screw and orientate it into position. *The correct foot for the load coupling/generator flange and SSS Clutch Output/Generator flange is marked "Generator End". Using the wrong foot on the generator end may cause damage to the flange. The generator end foot will not fit on the turbine end.*
9. Thread the tensioner onto the puller screw until it stops. Please note that the internal stop inside the tensioner will cause a gap in between the foot and tensioner. The gap should be 1/16" [1.6mm] to 3/16" [4.8mm]. **DO NOT ATTEMPT TO TIGHTEN THE TENSIONER AGAINST THE FOOT.**
- 9A. Place the guard over the tensioner and position the guide pin into the hole in the backside of the stud. **(Gas Turbine/Load Coupling flange and Gas Turbine/SSS Clutch Input flange Tensioner Only)**
- 9B. Place the orange guard over the tensioner and position the pocketed slots into the retention screws. **(Load Coupling/Generator and SSS Clutch Output/Generator flange Tensioner Only)**
10. Tighten the knurled interlock fitting by hand until it firmly presses against the tensioner. There should be no gap between the tensioner the interlock fitting.
11. The retention screws must be inside the guard's pocketed slots. **(Load Coupling/Generator and SSS Clutch Output/Generator flange Tensioner Only)**
12. Activate the custom connector from the rear of guard by pushing on the center with your thumb and pulling the tabs with your fore finger and middle finger. Push the assembly forward until it locks into the tensioner. Release fingers from the tabs and then remove thumb, ensure connection is firmly engaged or else the tensioner will not be connected to the pump.



215 Clinton Road  
New Hartford, NY 13413  
Tel: +1 315 768 4855  
Fax: +1 315 768 4941  
Email: info@riverhawk.com

CUSTOMER'S INFORMATION BOX

CONTENTS ARE INDEPENDENT OF RIVERHAWK DOCUMENT CONTROL

GE DRAWING NUMBER	REV
373A4072	

Revision K  
Page 28 of 49

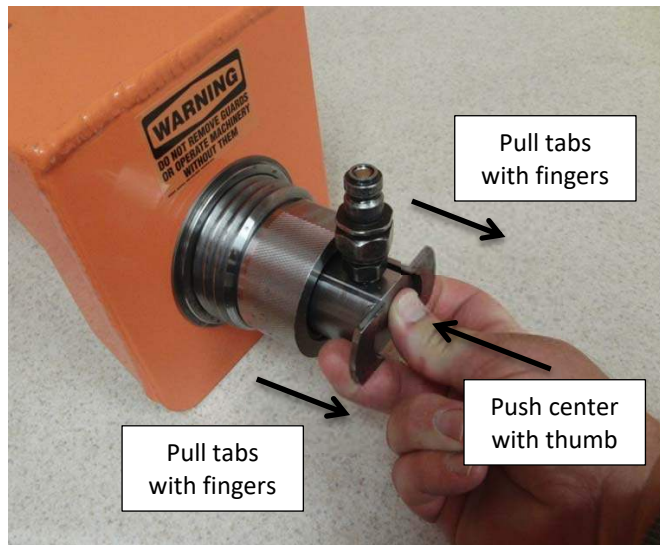

Picture 8E - Activation of the safety interlock

13. Install the backside guard by attaching it to the flange face. It should be centered over the stud to be tensioned. Magnets will temporarily hold the guard against the flange.  
**(Load Coupling/Generator and SSS Clutch Output/Generator flange Tensioner Only)**
14. Connect the hydraulic pump to the tensioner. The tensioner should now be completely assembled and ready for use.

### 8.3 Bleeding Hydraulic System

Bleeding of the hydraulic system is not necessary with this tensioner design.

### 9.0 Stud Tensioning

The studs will be tensioned in two steps, at 50% pressure and at final pressure. Follow the tensioning sequence for each flange joint as defined on the record sheets found at the end of this manual.

#### 9.1 Tensioning at 50% pressure

After the tensioner is properly installed apply hydraulic pressure to the tool. Bring the pressure to the 50% level in accordance with the following table.



215 Clinton Road  
 New Hartford, NY 13413  
 Tel: +1 315 768 4855  
 Fax: +1 315 768 4941  
 Email: info@riverhawk.com

CUSTOMER'S INFORMATION BOX  
 CONTENTS ARE INDEPENDENT OF RIVERHAWK DOCUMENT CONTROL

GE DRAWING NUMBER	REV
373A4072	

**WARNING**

The safety cage must be in place at all times. Keep hands out of designated areas at all times when the tensioner is pressurized otherwise personal injury can occur.

**CAUTION**

Before threading the puller screw into the stud, carefully check the cleanliness of both the stud's and the puller screw's conical threads. Apply a light coat of clean turbine oil or a spray lubricant to the puller screw. This procedure will ease assembly and assure positive mating of the threads before tightening. Do not use "Never Seize" on the conical threads.

**CAUTION**

Do not exceed the maximum pressure marked on the tensioner. Excessive pressure can damage the stud and puller screw.

**CAUTION**

Do not tighten the nut while the tool is coming up to pressure; wait until pressure is achieved before attempting to tighten the nut with the spanner ring. If the tool is not properly installed, the tool could jump off the stud while coming up to pressure.

<u>Flange Position</u>	<u>Stud Size</u>	<u>50% Pressure</u>	<u>50% Stretch</u>
Gas Turbine to Load <u>Coupling</u> Gas Turbine to SSS Clutch Input	2-1/4" [58 mm]	9000 psi [620 bar]	Do not measure Do not use
Load Coupling to <u>Generator</u> SSS Clutch Output to Generator	2-3/4" [71 mm]	10000 psi [690 bar]	Do not measure Do not use

Firmly tighten the cylindrical nuts with approximately 20 ft-lbs [27 N·m] of torque using the pin wrench and spanner ring. Turn the nut until it bottoms on the flange.

**9.2 Removing the Tensioner from an Installed Stud**

The tensioner removal is accomplished by the following steps:

1. Release the hydraulic pressure by either releasing the hand switch on the AP-0532 Pump Kit and leave the valve open.



215 Clinton Road  
New Hartford, NY 13413  
Tel: +1 315 768 4855  
Fax: +1 315 768 4941  
Email: info@riverhawk.com

CUSTOMER'S INFORMATION BOX  
CONTENTS ARE INDEPENDENT OF RIVERHAWK DOCUMENT CONTROL

GE DRAWING NUMBER	REV
373A4072	

2. Remove the backside guard. **(Load Coupling/Generator and SSS Clutch Output/Generator flange Tensioner Only)**
3. Unscrew the knurled interlock fitting at the end of the guard and remove the guard from the tensioner.
4. Unscrew the tensioner from puller screw.
5. Remove foot from around the puller screw.
6. Unscrew the puller screw using an Allen wrench. Tapping the Allen wrench with a hammer or the use of a 3-4' breaker bar may be necessary to loosen the puller screw. Do not use an impact wrench as this can damage the puller screw.
7. Remove the spanner ring from the nut.
8. In the case of the load coupling/generator and SSS clutch output/generator flanges, unscrew the retention screws using an Allen wrench. It may be necessary to tap the Allen wrench with a hammer or use a 3-4' breaker bar to loosen the retention screws. Do not use an impact wrench as this can damage the retention screws.
9. Move the tool to the next bolt hole following the tensioning pattern from the stretched record sheets at the end of this manual.

### 9.3 Tensioning at Final Pressure

Repeat the pulling and tightening procedure stated above at full pressure. After all of the studs have been tensioned, measure the final stud length. The final pressure and required stretch values are listed in the following table.

#### **WARNING**

**The safety cage must be in place at all times. Keep hands out of designated areas at all times when the tensioner is pressurized otherwise personal injury can occur.**

#### **CAUTION**

**Before threading the puller screw into the stud, carefully check the cleanliness of both the stud's and the puller screw's conical threads. Apply a light coat of clean turbine oil or a spray lubricant to the puller screw. This procedure will ease assembly and assure positive mating of the threads before tightening. Do not use "Never Seize" on the conical threads.**

#### **CAUTION**

**Do not exceed the maximum pressure marked on the tensioner. Excessive pressure can damage the stud and puller screw.**



215 Clinton Road  
New Hartford, NY 13413  
Tel: +1 315 768 4855  
Fax: +1 315 768 4941  
Email: info@riverhawk.com

#### CUSTOMER'S INFORMATION BOX

CONTENTS ARE INDEPENDENT OF RIVERHAWK DOCUMENT CONTROL

GE DRAWING NUMBER	REV
373A4072	

Revision K  
Page 31 of 49

**CAUTION**

**Do not tighten the nut while the tool is coming up to pressure; wait until pressure is achieved before attempting to tighten the nut with the spanner ring. If the tool is not properly installed, the tool could jump off the stud while coming up to pressure.**

<u>Flange Position</u>	<u>Stud Size</u>	<u>Final Pressure</u>	<u>Final Stretch</u>	<u>Gauge Reading</u>
Gas Turbine to <u>Load Coupling</u> Gas Turbine to SSS Clutch Input	2-1/4" [58 mm]	18000 psi [1240 bar]	0.018" - 0.021" [0.46 mm - 0.53 mm]	-----
Load Coupling to <u>Generator</u> SSS Clutch Output to Generator	2-3/4" [71 mm]	19000 psi [1310 bar]	0.014" - 0.016" [0.36 mm - 0.41 mm]	0.025"-0.030" [0.63mm-0.76mm]

Firmly tighten the cylindrical nuts with approximately 20 ft-lbs [27 N·m] of torque using the pin wrench and spanner ring. Turn the nut until it bottoms on the flange.

Failure to achieve the correct final stretch values will result in an incorrectly tensioned stud.

Incorrect stretch values can be corrected by uninstalling some or all of the selected studs. Re-measure the initial length of the studs and repeat the installation instructions studs. Excessive stretch variations can also be corrected by the same method.

Have final stretch values approved by the supervisor responsible for the installation.

**10.0 Thread Locking and Windage Plug Installation**



215 Clinton Road  
New Hartford, NY 13413  
Tel: +1 315 768 4855  
Fax: +1 315 768 4941  
Email: info@riverhawk.com

CUSTOMER'S INFORMATION BOX  
CONTENTS ARE INDEPENDENT OF RIVERHAWK DOCUMENT CONTROL

GE DRAWING NUMBER	REV
373A4072	

**10.1 Thread Locking**



**Picture 10A** - Riverhawk Locknut

Mechanical lock nuts have two set screws located in the top face. Before threading the nut onto the stud, check to be certain the set screws are free to turn. Once the nut is seated torque the set screws to the values specified in the following table. When seated and torqued to the values specified, the load created by the set screw displaces the thread of the nut in the area of the web thereby creating the desired locking action.

<u>Flange Position</u>	<u>Stud Size</u>	<u>Set Screw Size</u>	<u>Torque</u>
Gas Turbine to Load <u>Coupling</u> Gas Turbine to SSS Clutch Input	2-1/4" [58 mm]	1/4"-28 UN	70 in·lbs - 80 in·lbs [7.9 N·m – 9.0 N·m]
Load Coupling to <u>Generator</u> SSS Clutch Output to Generator	2-3/4" [71 mm]	3/8"-24 UN	200 in·lbs - 250 in·lbs [22.6 N·m – 28.2 N·m]

**10.2 Windage Plug Installation**

Refer to the hardware assembly drawing (HF-xxxx) listed in Section 2.0 of this manual to determine if windage plugs are required for the installation. Along with other identifying



215 Clinton Road  
New Hartford, NY 13413  
Tel: +1 315 768 4855  
Fax: +1 315 768 4941  
Email: info@riverhawk.com

CUSTOMER'S INFORMATION BOX  
CONTENTS ARE INDEPENDENT OF RIVERHAWK DOCUMENT CONTROL

GE DRAWING NUMBER	REV
373A4072	

markings, the windage plug's part number can be found on the plug's top surface as shown in the picture below.



**Picture 10B** – Windage Plug's Markings

To install the windage plug, use the following instructions:

1. Inspect the stud's conical thread. It should have a bright and shiny appearance. The threads should be visually checked for any damage. Refer to Section 5.2 or Riverhawk Instruction Manual IM-220 (GE Vendoc 373A4025) for assistance.
2. Apply a light coat of clean turbine oil to the stud.

**CAUTION**

Before installation, carefully check the cleanliness of the windage plug's and the stud's threads. Apply a light coat of clean turbine oil to the stud's conical thread. This procedure will ease assembly before tightening. Do not use "Never Seize" on any surface or thread.



215 Clinton Road  
New Hartford, NY 13413  
Tel: +1 315 768 4855  
Fax: +1 315 768 4941  
Email: info@riverhawk.com

**CUSTOMER'S INFORMATION BOX**  
CONTENTS ARE INDEPENDENT OF RIVERHAWK DOCUMENT CONTROL

GE DRAWING NUMBER	REV
373A4072	

- Thread the windage plug into the conical thread of the stud. The windage plug must not be cross-threaded when installed. Apply the following torque to seat the windage plug into the stud.

Windage Plug P/N	Installation Torque
7002259	200-250 in-lbs. [22.6-28.2 Nm]

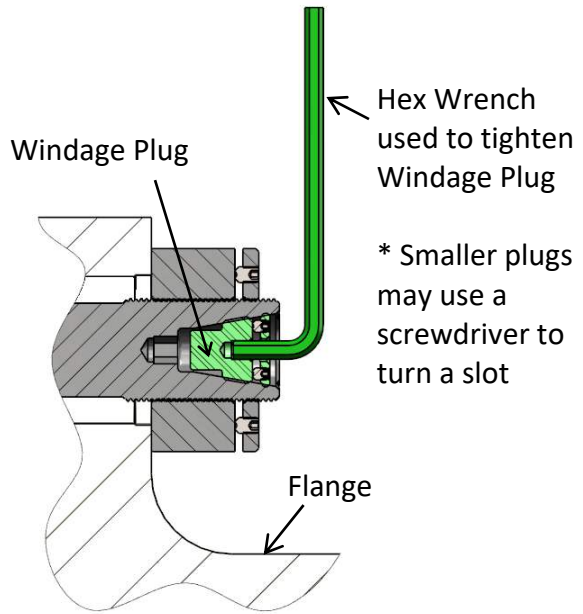

Figure 10C

- The windage plug includes a locking feature similar to the locking feature of the cylindrical nuts. The set screws must be torqued to the following amount. These set screws will cause the top section of the windage plug to lock onto the stud's threads.

Windage Plug P/N	Installation Torque
7002259	80-90 in-lbs. [9.0-10.1 Nm]

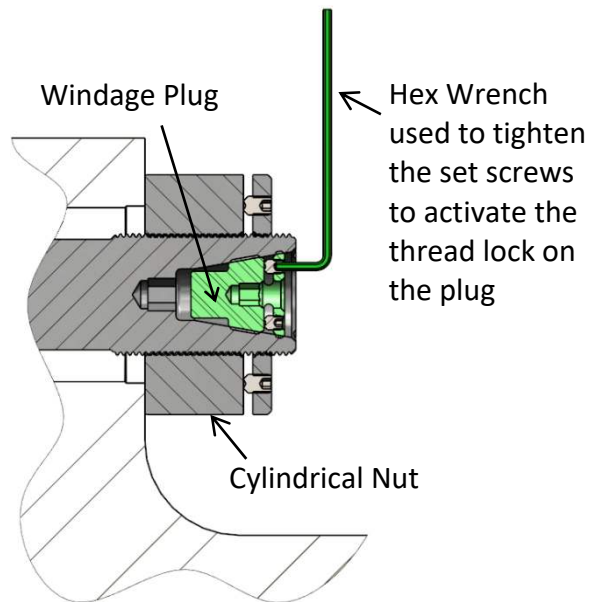

Figure 10D

**WARNING**

Do not use liquid thread locker (for example: Loctite) on any of the threads and do not stake any component of this assembly.



215 Clinton Road  
New Hartford, NY 13413  
Tel: +1 315 768 4855  
Fax: +1 315 768 4941  
Email: info@riverhawk.com

**CUSTOMER'S INFORMATION BOX**  
CONTENTS ARE INDEPENDENT OF RIVERHAWK DOCUMENT CONTROL

GE DRAWING NUMBER	REV
373A4072	

5. The windage plug should be at least 0.060" [1.5 mm] below the face of the stud for the locking feature to work correctly. If not, loosen set screws and reexamine the stud's and plug's threads for debris or damage. It may be necessary to replace the plug.
6. The set screws should flush to slightly below the top of the windage plug. The set screw should also press against the slot's opposite surface.

**Wrong Installation Position**



Partially Loose Set screw

**Correct Installation Position**



Pressed against Opposite Surface. No Gap.

**Picture 10E – Set Screw Position**

**11.0 Stud and Nut Removal**

**11.1 Handling of the Tensioner**

The tensioner used in this application is designed for no special lifting instructions. Do not drop any part of the tensioner on the operator or other nearby personnel.

**11.2 Stud and Nut Removal**

**WARNING**

**The safety cage must be in place at all times. Keep hands out of designated areas at all times when the tensioner is pressurized otherwise personal injury can occur.**

**CAUTION**

**Before threading the puller screw into the stud, carefully check the cleanliness of both the stud's and the puller screw's conical threads. Apply a light coat of clean turbine oil or a spray lubricant to the puller screw. This procedure will ease assembly and assure positive mating of the threads before tightening. Do not use "Never Seize" on the conical threads.**



215 Clinton Road  
 New Hartford, NY 13413  
 Tel: +1 315 768 4855  
 Fax: +1 315 768 4941  
 Email: info@riverhawk.com

**CUSTOMER'S INFORMATION BOX**  
 CONTENTS ARE INDEPENDENT OF RIVERHAWK DOCUMENT CONTROL

GE DRAWING NUMBER	REV
373A4072	

**CAUTION**

**Do not exceed the maximum pressure marked on the tensioner. Excessive pressure can damage the stud and puller screw.**

**CAUTION**

**Do not tighten the nut while the tool is coming up to pressure; wait until pressure is achieved before attempting to tighten the nut with the spanner ring. If the tool is not properly installed, the tool could jump off the stud while coming up to pressure.**

Refer to the hardware assembly drawing (HF-xxxx) listed in Section 2.0 of this manual and the tensioner assembly drawing (HT-xxxx) listed in Section 4.5 of this manual to determine how the tensioner must be assembled on the load coupling for its correct operation.

Section 8.0 contains diagrams of the tensioner equipment.

**Note: Before threading the puller screw into the stud, carefully check the cleanliness of both the stud's and the puller screw's conical threads. Apply a light coat of clean turbine oil or a spray lubricant to the puller screw. Do not use "Never Seize" on the conical threads. This procedure will ease assembly and assure positive mating of the threads before tightening.**

Disassembly sequence is as follows:

1. If present, remove the windage plugs from the studs by reversing the installation instructions from section 10.2. It may be necessary to use two Allen wrenches: one to stop the windage plug from rotating, one to remove the set screws. Do not misplace the set screws.
2. Using a wire brush (GT-4253) and shop air, clean the internal tapered thread of the stud to remove any debris/deposits which may have accumulated during service as described in section 5.2.2. Do not continue until ALL debris is removed from the threads.

**WARNING**

**Do not use a hydraulic tensioner to remove a stud with damaged conical threads.**

3. With an Allen-wrench loosen the two locking set screws but do not remove from the nut.



215 Clinton Road  
New Hartford, NY 13413  
Tel: +1 315 768 4855  
Fax: +1 315 768 4941  
Email: info@riverhawk.com

CUSTOMER'S INFORMATION BOX  
CONTENTS ARE INDEPENDENT OF RIVERHAWK DOCUMENT CONTROL

GE DRAWING NUMBER	REV
373A4072	

Revision K  
Page 37 of 49



**Picture 11A** - Loosening of a nut's set screws

4. Connect the hydraulic hose from the hydraulic pump to the tensioner.
5. Open the hydraulic return valve on the pump to allow hydraulic fluid to be pushed back from the puller tool into the pump reservoir. (This is automatic on the air-operated hydraulic pump)
6. Thread the retention screws into the adjacent studs on either side of the stud to be tensioned until hand tight. **(Load Coupling/Generator and SSS Clutch Output/Generator flange Tensioner Only)**
7. Place the spanner ring on the nut.
8. Insert the puller screw release tape per Riverhawk manual IM-336.
9. Insert the puller screw into the tapered thread of the stud and hand tighten. **Be sure not to cross-thread the puller screw.**
10. Using an Allen wrench, tighten the puller screw and then back off the puller screw 1/2 a turn. Retighten the puller screw by hand until it is fully inserted. **DO NOT BACK OFF THE PULLER SCREW.**
11. Place the correct foot over the puller screw and orientate it into position. *The correct foot for the load coupling/generator flange and SSS Clutch Output/Generator flange is marked "Generator End". Using the wrong foot on the generator end may cause damage to the flange. The generator end foot will not fit on the turbine end.*
12. Thread the tensioner onto the puller screw until it stops. Please note that the internal stop inside the tensioner will cause a gap in between the foot and tensioner. The gap should be 1/16" [1.6mm] to 3/16" [4.8mm]. **DO NOT ATTEMPT TO TIGHTEN THE TENSIONER AGAINST THE FOOT.**

CUSTOMER'S INFORMATION BOX

CONTENTS ARE INDEPENDENT OF RIVERHAWK DOCUMENT CONTROL

GE DRAWING NUMBER	REV
373A4072	



215 Clinton Road  
 New Hartford, NY 13413  
 Tel: +1 315 768 4855  
 Fax: +1 315 768 4941  
 Email: info@riverhawk.com

- 11A. Place the guard over the tensioner and position the guide pin into the hole in the backside of the stud. **(Gas Turbine/Load Coupling flange and Gas Turbine/SSS Clutch Input flange Tensioner Only)**
- 11B. Place the orange guard over the tensioner and position the pocketed slots into the retention screws. **(Load Coupling/Generator and SSS Clutch Output/Generator flange Tensioner Only)**
12. Tighten the knurled interlock fitting by hand until it firmly presses against the tensioner. There should be no gap between the tensioner the interlock fitting.
13. The retention screws must be inside the guard's pocketed slots. **(Load Coupling/Generator and SSS Clutch Output/Generator flange Tensioner Only)**
14. Activate the custom connector from the rear of guard by pushing on the center with your thumb and pulling the tabs with your fore finger and middle finger. Push the assembly forward until it locks into the tensioner. Release fingers from the tabs and then remove thumb, ensure connection is firmly engaged or else the tensioner will not be connected to the pump.

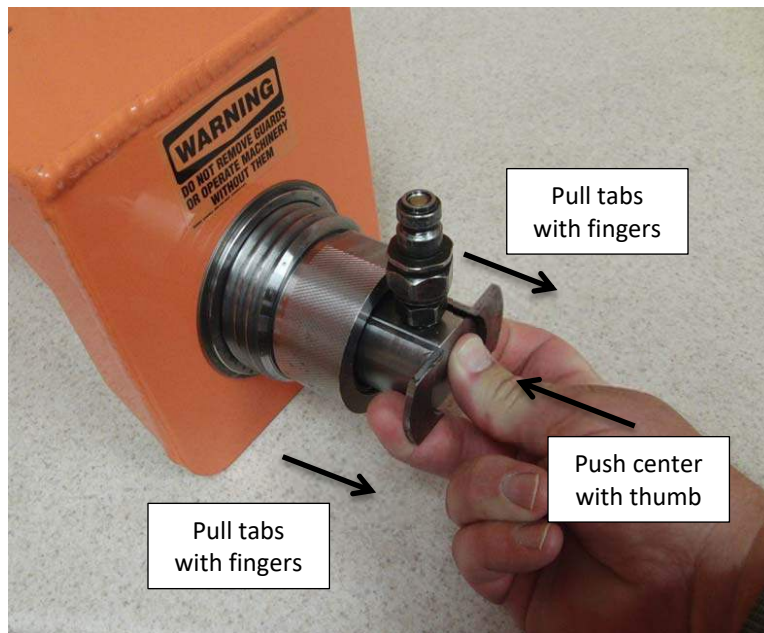

**Picture 11B** - Activation of the safety interlock

15. Install the backside guard by attaching it to the flange face. It should be centered over the stud to be tensioned. Magnets will hold the guard against the flange. **(Load Coupling/Generator and SSS Clutch Output/Generator flange Tensioner Only)**



215 Clinton Road  
 New Hartford, NY 13413  
 Tel: +1 315 768 4855  
 Fax: +1 315 768 4941  
 Email: info@riverhawk.com

CUSTOMER'S INFORMATION BOX  
 CONTENTS ARE INDEPENDENT OF RIVERHAWK DOCUMENT CONTROL

GE DRAWING NUMBER	REV
373A4072	

16. Connect the hydraulic pump to the tensioner and apply the appropriate hydraulic pressure per this table.

<u>Flange Position</u>	<u>Stud Size</u>	<u>Removal Pressure</u>
Gas Turbine to <u>Load Coupling</u> Gas Turbine to SSS Clutch Input	2-1/4" [58 mm]	18000 psi [1240 bar]
Load Coupling to <u>Generator</u> SSS Clutch Output to Generator	2-3/4" [71 mm]	19000 psi [1310 bar]

17. Turn the spanner ring with the pin wrench. Loosen and turn the nut approximately 3/4 of a turn.
18. Release the hydraulic pressure.

### 11.3.1 Removing the Tensioner from a Stud

The tensioner removal is accomplished by the following steps:

1. Release the hydraulic pressure by either releasing the hand switch on the AP-0532 Pump Kit and leave the valve open.
2. Remove the backside guard. **(Load Coupling/Generator and SSS Clutch Output/Generator flange Tensioner Only)**
3. Unscrew the knurled interlock fitting at the end of the guard and remove the guard from the tensioner.
4. Unscrew the tensioner from puller screw.
5. Remove foot from around the puller screw.
6. Unscrew the puller screw using an Allen wrench. Tapping the Allen wrench with a hammer or the use of a 3-4' breaker bar may be necessary to loosen the puller screw. Do not use an impact wrench as this can damage the puller screw.
7. Remove the spanner ring from the nut.
8. In the case of the load coupling/generator and SSS clutch output/generator flanges, unscrew the retention screws using an Allen wrench. It may be necessary to tap the

**CUSTOMER'S INFORMATION BOX**

CONTENTS ARE INDEPENDENT OF RIVERHAWK DOCUMENT CONTROL

GE DRAWING NUMBER	REV
373A4072	



215 Clinton Road  
New Hartford, NY 13413  
Tel: +1 315 768 4855  
Fax: +1 315 768 4941  
Email: info@riverhawk.com

Allen wrench with a hammer or use a 3-4' breaker bar to loosen the retention screws. Do not use an impact wrench as this can damage the retention screws.

9. Move the tool to the next bolt hole following the tensioning pattern from the stretched record sheets at the end of this manual.

## 12.0 Storage Instructions

Follow these directions to properly store your hydraulic tensioner and hydraulic pump kit for long term storage and shipment.

If any damage is observed, contact the Riverhawk Company to schedule a maintenance inspection.

### 12.1 Hydraulic Pump Kit Storage

Refer to the Hydraulic Pump Kit Instruction Manual, IM-293 (GE VENDOC 373A4058). The latest revision may be obtained by contacting Riverhawk Company or thru [www.riverhawk.com](http://www.riverhawk.com).

### 12.2 Hydraulic Tensioner Storage

Check the tensioner for any damage

1. Clean puller screw and check for any debris and dents.
2. Knurled interlock fitting should be clean and free to rotate.
3. Inspect the tensioner guard for any signs of damage. Bent guards must be replaced.

If any damage is observed, contact the Riverhawk Company to schedule a maintenance inspection.

Place the protective plastic cap on the guard's knurled interlock fitting.

Coat the hydraulic tensioner with a light coat of oil and place the tensioner into the original shipping container.

### 12.3 Store shipping container

Secure the hydraulic pump and hydraulic tensioner into the original shipping containers using the supplied wood braces.



215 Clinton Road  
New Hartford, NY 13413  
Tel: +1 315 768 4855  
Fax: +1 315 768 4941  
Email: [info@riverhawk.com](mailto:info@riverhawk.com)

#### CUSTOMER'S INFORMATION BOX

CONTENTS ARE INDEPENDENT OF RIVERHAWK DOCUMENT CONTROL

GE DRAWING NUMBER	REV
373A4072	

Revision K  
Page 41 of 49

Seal the original shipping container and store under shelter and protected from moisture, sand, and grit.

### 13.0 Frequently Asked Questions

This section contains some frequently asked questions and problems. If the steps listed here do not solve your problem, contact the Riverhawk Company thru our website, email, or phone call.

**Q:** Can I rent a hydraulic tensioner kit?

**A:** Yes, Riverhawk has rental tensioner kits available for most of our hydraulic tensioners.

**Q:** A tensioner has pulled itself out of the stud's conical threads. Can I continue using a tensioner on this stud?

**A:** No. Both the tensioner and the stud may have been damaged and must be removed from the work area. If the stud is tensioned, a Nut Buster repair kit, from Riverhawk, must be used to remove the damaged stud by drilling out the nut. Leaving a damaged stud in place will lead to a safety hazard on future outages.

Riverhawk can supply a replacement stud and nut based on the initial weight certification supplied with the hardware set (see section 4.2). The damaged tensioner should also be returned to Riverhawk for inspection and repair.

If a stud must be left in place, paint the damaged stud with a generous amount of indelible, bright-colored paint. Notify the appropriate GE Safety and Service personnel. Note the location of the damaged stud in the services notes for the machine.

**Q:** The hydraulic tensioner has been taken up to its final pressure. The final stretch length is short of the final stretch target. What is the next step?

**A:** Do not increase the hydraulic pressure. Check if the hydraulic pump is set to the right pressure. Install the tensioner and re-pressurize the tensioner to the final pressure then recheck the stretch measurement. If the stretch value is still short, remove the stud from the hole and re-measure the stud's initial length then try to install the stud again.



215 Clinton Road  
New Hartford, NY 13413  
Tel: +1 315 768 4855  
Fax: +1 315 768 4941  
Email: info@riverhawk.com

**CUSTOMER'S INFORMATION BOX**

CONTENTS ARE INDEPENDENT OF RIVERHAWK DOCUMENT CONTROL

GE DRAWING NUMBER	REV
373A4072	

Revision K  
Page 42 of 49

**Q:** The hydraulic tensioner has been taken up to its final pressure. The final stretch length is larger than the final stretch target. What is the next step?

**A:** Remove the stud from the bolt hole. Check if the hydraulic pump is set to the right pressure. Re-measure the stud's initial length then try to install the stud again.

**Q:** The tensioner is at its final pressure, but the nut cannot be loosened.

**A:** If the nuts cannot be loosened at the final pressure, continually increasing the pressure will not help and can be dangerous and in some cases make it harder to remove the nut. Check the nut to see if its set screws have been loosened. Check for and remove any corrosion around the nut's threads. Apply penetrating oil between the stud and the nut.

**Q:** How do I clean the conical threads on a stud?

**A:** The conical threads are best cleaned using a spiral wound brass brush in a drill as described in section 5.2.2

**Q:** During the initial steps of removing a tensioned stud, the stick-out length is found to be wrong.

**A:** Do not proceed. Contact Riverhawk for assistance. With the wrong stick-out length, the hydraulic tensioner has a limited stroke and may not work properly and can be damaged.

**Q:** The hydraulic pump appears to be leaking.

**A:** Check the hose connection to the hydraulic pump. If the 1/4" high pressure fitting is not assembled correctly as shown in section 7.2, it may look like the pump is leaking. If the problem continues, it may be necessary to open the pump kit. Contact Riverhawk for guidance.



215 Clinton Road  
New Hartford, NY 13413  
Tel: +1 315 768 4855  
Fax: +1 315 768 4941  
Email: info@riverhawk.com

**CUSTOMER'S INFORMATION BOX**

CONTENTS ARE INDEPENDENT OF RIVERHAWK DOCUMENT CONTROL

GE DRAWING NUMBER	REV
373A4072	

- Q:** The hydraulic hose has a collar on it that can't be moved by hand
- A:** The hydraulic fitting is shown in section 7.2. The collar is sometimes held in place with a thread locking compound. This prevents the collar from moving too easily. It may be necessary to adjust this collar with a set of vise-grip pliers. Be careful to not strip the threads off the tube or hose end.

**14.0 Revision History**

Revision Letter	Effective Date	Description
K	Apr 8, 2026	Added 327T9308P001 thru P008 to title page and section 2
J	Mar 13, 2026	Added 106T1751P009 – P014 to title page and section 2; added references to SSS clutch to customer equipment descriptions; Inserted Picture 8D; Added section 10.2
H	Jan 26, 2022	Updated EC Declaration of Conformity; Added UKCA Declaration of Conformity
G	Jan 31, 2019	Added 106T1751P006, P007, and P008 to title page and section 2.4
F	Jan 20, 2016	Final stretch measurement for 2-1/4" stud was .020"-.022" [0.51mm-0.56mm] section 9.3
E	Oct 26, 2015	Rearranged appendices, Revised table in section 11.2, Revised section 2, Inserted section 8.2
D	Jan 16, 2015	Updated sections 1.0, 4.3 and appendix A3.
C	Jun 16, 2014	Added EC Declaration of Conformity. Added instructions for separate feet.



215 Clinton Road  
 New Hartford, NY 13413  
 Tel: +1 315 768 4855  
 Fax: +1 315 768 4941  
 Email: info@riverhawk.com

**CUSTOMER'S INFORMATION BOX**  
 CONTENTS ARE INDEPENDENT OF RIVERHAWK DOCUMENT CONTROL

GE DRAWING NUMBER	REV
373A4072	

Instruction Manual IM-327

B	Feb 17, 2014	Section 3.0 & 6.0 Removed hand tighten, added tighten with spanner ring, Section 3.0 & 6.0 added measure and record starting gage readings (generator side), Section 5.3.2 revised stud stretch measurement gauge to read stud installation gauge, Section 9.3 added gage reading column to final installation chart (generator side), Appendix 2 renamed final stretch to final gauge reading
A	Dec 19, 2013	Corrected Riverhawk part numbers was HT-5144 is now HT-6282. Corrected GE part numbers was 269B8713 is now 269B8772. Updated Riverhawk & GE part numbers for hardware sets section 2.
-	Nov 27, 2013	Released



215 Clinton Road  
 New Hartford, NY 13413  
 Tel: +1 315 768 4855  
 Fax: +1 315 768 4941  
 Email: info@riverhawk.com

**CUSTOMER'S INFORMATION BOX**  
 CONTENTS ARE INDEPENDENT OF RIVERHAWK DOCUMENT CONTROL

GE DRAWING NUMBER	REV
373A4072	

## Appendix A1

### EC Declaration of Conformity

Manufacturer: Riverhawk Company  
Address: 215 Clinton Road  
New Hartford, NY 13413, USA

The hydraulic pump and bolt tensioning tool described in this manual are used for installing and applying tension to large bolts that are specifically designed by Riverhawk Company to be tensioned hydraulically.

All applicable sections of European Directive 2006/42/EC for machinery have been applied and fulfilled in the design and manufacture of the hydraulic pump and bolt tensioning tool described in this manual. Reference also ISO 12100:2010, ISO 4413:2010, and ISO 4414:2010.

Furthermore, this equipment has been manufactured under the Riverhawk quality system per EN ISO 9001:2015

Consult the Declaration of Conformance included with the shipment of this equipment that identifies the authorized Riverhawk representative, applicable serial numbers, and appropriate signature.



215 Clinton Road  
New Hartford, NY 13413  
Tel: +1 315 768 4855  
Fax: +1 315 768 4941  
Email: info@riverhawk.com

#### CUSTOMER'S INFORMATION BOX

CONTENTS ARE INDEPENDENT OF RIVERHAWK DOCUMENT CONTROL

GE DRAWING NUMBER	REV
373A4072	

Revision K  
Page 46 of 49

## Appendix A2

### UKCA Declaration of Conformity

Manufacturer: Riverhawk Company  
Address: 215 Clinton Road  
New Hartford, NY 13413, USA

The hydraulic pump and bolt tensioning tool described in this manual are used for installing and applying tension to large bolts that are specifically designed by Riverhawk Company to be tensioned hydraulically.

All applicable sections of Supply of Machinery (Safety) 2008 have been applied and fulfilled in the design and manufacture of the hydraulic pump and bolt tensioning tool described in this manual. Reference also ISO 12100:2010, ISO 4413:2010, and ISO 4414:2010.

Furthermore, this equipment has been manufactured under the Riverhawk quality system per EN ISO 9001:2015

Consult the Declaration of Conformance included with the shipment of this equipment that identifies the authorized Riverhawk representative, applicable serial numbers, and appropriate signature.



215 Clinton Road  
New Hartford, NY 13413  
Tel: +1 315 768 4855  
Fax: +1 315 768 4941  
Email: info@riverhawk.com

#### CUSTOMER'S INFORMATION BOX

CONTENTS ARE INDEPENDENT OF RIVERHAWK DOCUMENT CONTROL

GE DRAWING NUMBER	REV
373A4072	

Revision K  
Page 47 of 49

**Appendix B1**

STRETCH RECORD SHEET FOR  
THE GAS TURBINE TO LOAD COUPLING

TURBINE NUMBER:

DATE:

TECHNICIAN:

SUPERVISOR:

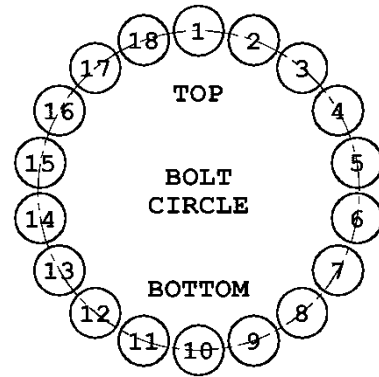

HOLE NUMBER	STARTING LENGTH	FINAL LENGTH	FINAL STRETCH
1			
10			
2			
11			
3			
12			
4			
13			
5			
14			
6			
15			
7			
16			
8			
17			
9			
18			

**CUSTOMER'S INFORMATION BOX**

CONTENTS ARE INDEPENDENT OF RIVERHAWK DOCUMENT CONTROL

GE DRAWING NUMBER	REV
373A4072	



215 Clinton Road  
New Hartford, NY 13413  
Tel: +1 315 768 4855  
Fax: +1 315 768 4941  
Email: info@riverhawk.com

**Appendix B2**

STRETCH RECORD SHEET FOR  
THE LOAD COUPLING TO GENERATOR

TURBINE NUMBER:

DATE:

TECHNICIAN:

SUPERVISOR:

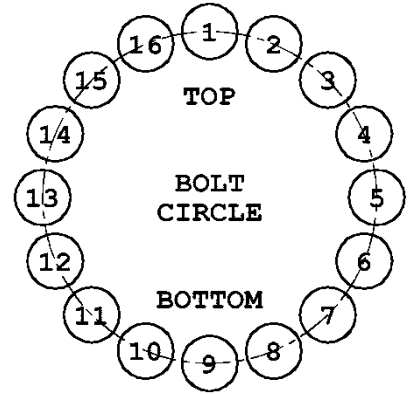

HOLE NUMBER	STARTING MEASUREMENT	FINAL MEASUREMENT	FINAL GAUGE READING
1			
9			
5			
13			
15			
7			
3			
11			
8			
16			
12			
4			
10			
2			
6			
14			

**CUSTOMER'S INFORMATION BOX**

CONTENTS ARE INDEPENDENT OF RIVERHAWK DOCUMENT CONTROL

GE DRAWING NUMBER	REV
373A4072	



215 Clinton Road  
New Hartford, NY 13413  
Tel: +1 315 768 4855  
Fax: +1 315 768 4941  
Email: info@riverhawk.com