

RING AND PLUG GAGES



Shaft End Tooling

At Riverhawk we have designed a full range of plug and ring gages developed specifically for the rotating machinery used in the petrochemical industry. Our gages are supplied with a certification and calibration traceable to N.I.S.T. They meet or exceed all API 671 requirements.

- Full Range - Designed and machined to match machine shaft ends.
- Taper Contact 90% to 95% guaranteed, bluing tapes provided.
- Meets or Exceeds API Requirements.
- Manufactured in most materials including: UNS 8620, 06 Tool Steel,

A6 Tool Steel, and Stainless Steel. Double thermal Stabilized for longevity of size.

- Calibration, Certification and storage services available.
- Chrome plate repair. All salvaged gauges come with the same warranty as new gages.



RING AND PLUG GAGES

Riverhawk Standard Gage Tolerances:

Large End Tolerance of +/- .0001

Taper Tolerance +/- .00005 TPI

90% Contact Minimum

Length Tolerance +/- .005

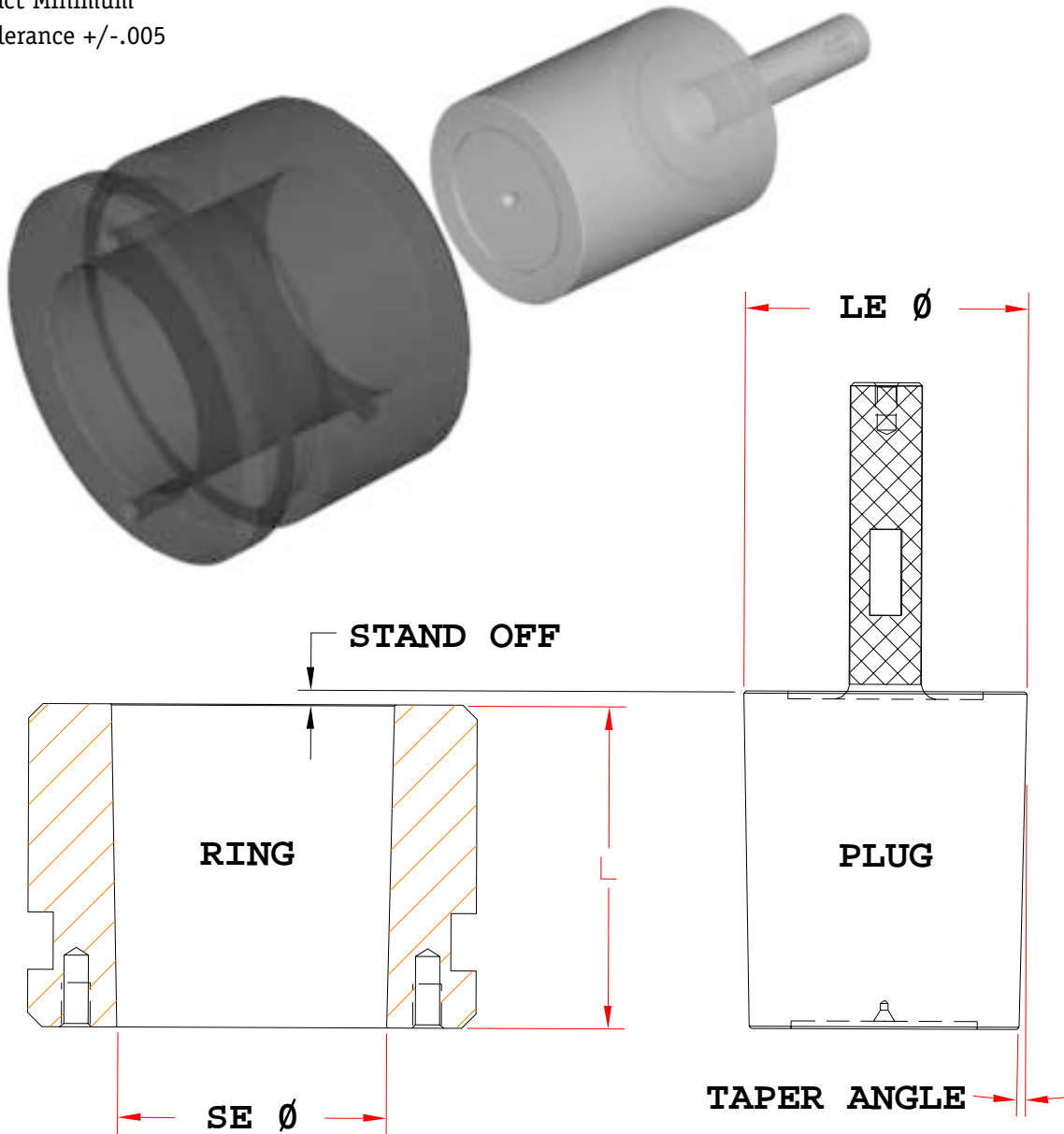

Riverhawk Company, an engineering driven manufacturer, specializes in hydraulic shaft joining technologies. We meet the daily challenges of the rotating equipment industry by offering auxiliary equipment such as air driven and manual hydraulic pressure kits and pusher piston cylinders for the installation of coupling hubs, thrust discs, and compressor wheels. Riverhawk also designs and manufactures hydraulically tensioned studs and nuts, tensioning tools, hydraulic nuts, and plug and ring gages. We also provide source inspections and training seminars. Our equipment is proudly supplied to the top OEMs and end users of the turbomachinery industry. Riverhawk is a member of the American Petroleum Institute (API) and sits on the coupling committee of the American Gear Manufacturers Association (AGMA).

For more information about Riverhawk's Ring and Plug Gages or any of our other products and services call



215 Clinton Road, New Hartford, NY 13413
Phone: 315-768-4855 Fax: 315-768-4941
sales@riverhawk.com <http://www.riverhawk.com>