

REVISION LETTER	GE ALTERATION NOTICE NUMBER

**INSTRUCTION MANUAL IM-150
For Gas/Steam Turbine Tensioned Studs and Nuts**

**Fr.6C Turbine to 6A8 Generator GE381A6851
Steam Turbine to 6A8 Generator GE382A4352**

GE Power Generation		GENERAL ELECTRIC COMPANY Schenectady, NY	
<u>VENDOR SUPPLIED DRAWING</u>			
GE NOT TO REVISE. GE REVISION LEVEL IS AS SHOWN ON THIS APPLIQUE. THIS DOCUMENT IS FILED UNDER THE GE DRAWING NUMBER			
THIS DOCUMENT SHALL BE REVISED IN ITS ENTIRETY. ALL SHEETS OF THIS DOCUMENT ARE THE SAME REVISION LEVEL AS INDICATED IN THIS VENDOR SUPPLIED DRAWING APPLIQUE			
FIRST MADE FOR:			___ OF ___
GE SIGNATURES	DATE	GE DRAWING NUMBER	REV
CHECKED		373A4006	D
ISSUED			

The Riverhawk Company reserves the right to make changes updating this document without dissemination or notice. The latest revision level may be obtained by contacting Riverhawk Company directly or visit our website at www.riverhawk.com



215 Clinton Road.
New Hartford, NY 13413
Tel: 315-768-4855
Fax: 315-768-4941
Email: info@riverhawk.com

**Instruction Manual IM-150
For Gas/Steam Turbine Tensioned Studs & Nuts**

Table of Contents

Section	Description	Page Number
1.0	Cautions and Safety Warnings	3
2.0	Scope	4
3.0	Quick Check-List	5
4.0	General Preparations	8
5.0	Preparation of Hardware	10
6.0	Nut and Stud Assembly	12
7.0	Assembly of Hydraulic Tensioner Equipment	12
8.0	Assembly of Tensioner on Stud	14
9.0	Stud Pulling and Tensioning	16
10.0	Retensioning	18
11.0	Thread Locking	18
12.0	Stud/Nut Removal	19
13.0	Frequently Asked Questions	20
14.0	Revision History	23



215 Clinton Road.
New Hartford, NY 13413
Tel: 315-768-4855
Fax: 315-768-4941
Email: info@riverhawk.com

GE DRAWING NUMBER	REV.
373A4006	D
FIRST MADE FOR:	SH.

1.0 Cautions and Safety Warnings

CAUTION

Personal injury and equipment damage can occur if the puller screw is not securely engaged with the tapered thread of the stud. Proper engagement is achieved when the puller screw is tight in the stud and the Tensioner Assembly is free to rotate.

WARNING

The safety cage MUST be in place and hands kept out of designated areas at all times when the tensioner is pressurized otherwise personal injury can occur.

CAUTION

DO NOT EXCEED THE MAXIMUM PRESSURE VIBROSCRIBED ON THE PULLER BODY. Excessive pressure can damage the stud and the puller screw.

WARNING

Fire Hazard! DO NOT heat when the puller assembly is in place. Personal injury or equipment damage may occur. Use of an Oxy-Acetylene torch is not recommended.

NOTICE

Do not use more thread locking compound than specified or the nut may be VERY difficult to remove at disassembly.

CAUTION

DO NOT EXCEED THE MAXIMUM PRESSURE VIBROSCRIBED ON THE PULLER BODY. Excessive pressure can damage the stud and puller screw

Note: Before threading the puller screw into the stud, carefully check the cleanliness of both the stud's and the puller screw's conical threads. Apply a light coat of clean turbine oil or a spray lubricant to the puller screw. Do not use "Never Seize" on the conical threads. This procedure will ease assembly and assure positive mating of the threads before tightening.



215 Clinton Road.
New Hartford, NY 13413
Tel: 315-768-4855
Fax: 315-768-4941
Email: info@riverhawk.com

GE DRAWING NUMBER	REV.
373A4006	D
FIRST MADE FOR:	SH.

**Instruction Manual IM-150
For Gas/Steam Turbine Tensioned Studs & Nuts**

2.0 Scope

This document describes the procedure to be used to install the stud and nut sets supplied by the Riverhawk Company in the flanges at the Turbine/Coupling, Coupling/Gear and Gear/Generator connections.

The various frame configurations covered in this manual are listed in Sections 2.1 through 2.2 with differences as related to connective hardware defined. Listed also are the pertinent hardware drawings (HF-). These drawings as well as tooling drawings (HT-) form part of this manual.

2.1 Fr. 6C Turbine to 6A8 Generator GE 381A6851

HF-2267, HT-2268, HT-2286

The hardware drawing depicts the stud and nut set for both Turbine to Load Coupling and Coupling to Gearbox (1 1/8" [29 mm] size, Qty 48) as well as Gearbox to Generator (1 5/8" [41 mm] size, Qty 40)

2.2 Steam Turbine to 6A8 Generator GE 382A4352

HF-2312, HT-2268

The hardware drawing depicts the stud and nut set for both Turbine to Generator (1 5/8" [41 mm] size, Qty 40)



215 Clinton Road.
New Hartford, NY 13413
Tel: 315-768-4855
Fax: 315-768-4941
Email: info@riverhawk.com

GE DRAWING NUMBER	REV.
373A4006	D
FIRST MADE FOR:	SH.

**Instruction Manual IM-150
For Gas/Steam Turbine Tensioned Studs & Nuts**

3.0 Quick Checklist

The following checklist is intended as a summary of the steps needed to use the Riverhawk-supplied equipment. New personnel or those experienced personnel who have not used the Riverhawk equipment recently are encouraged to read the entire manual.

EQUIPMENT INSPECTION

- Check oil level in hydraulic pump.
- Check air pressure at 80 psi [5.5 bar] minimum. (For air-driven pumps)
- Check hydraulic hose for damage.
- Test pump.
- Inspect tensioner for any damage.

NUT AND STUD PREPARATION

- Inspect stud and nuts for any damage.
- Measure stud length.
- Clean the studs and nuts.
- Install studs and nuts (off-center) into the flange.
- Set stick-out dimension on stud end with the internal, conical thread.
- Hand tighten all studs.
- Verify stick-out measurement (VERY IMPORTANT)



215 Clinton Road.
New Hartford, NY 13413
Tel: 315-768-4855
Fax: 315-768-4941
Email: info@riverhawk.com

GE DRAWING NUMBER	REV.
373A4006	D
FIRST MADE FOR:	SH.

Instruction Manual IM-150
For Gas/Steam Turbine Tensioned Studs & Nuts

Tensioning (Bolt installation)

- Match the tensioner setup to the flange joint.
- Apply a light coat of clean turbine oil or spray lubricant to the puller screw. **DO NOT USE "NEVER SEIZE" ON THE CONICAL THREADS.**
- Slide spanner ring over the puller screw.
- Mount the tensioner on the stud in flange and install spanner ring onto nut.
- Insert 3/8" hex Allen wrench into the back side of the stud.
- Tighten the puller screw. Then back off puller screw 1/2 a turn.
- Retighten the puller screw and leave tight. **DO NOT BACK OFF PULLER SCREW.**
- Tighten puller nut and then back nut off two flats or 120 degrees to allow for stud stretch.
- Bleed the tensioner. **Do NOT bleed tensioner off of a stud! Damage to the tool will result!**
- Tension to 50%. Consult manual for correct pressure.
- Use the pin wrench in spanner ring to tighten nut.
- Release pressure, move to next stud in pattern.
- Repeat above steps at final pressure.
- Measure final stud length and record on stretch datasheets. Calculate stretch.
- Torque nuts' set screws.



215 Clinton Road.
New Hartford, NY 13413
Tel: 315-768-4855
Fax: 315-768-4941
Email: info@riverhawk.com

GE DRAWING NUMBER	REV.
373A4006	D
FIRST MADE FOR:	SH.

Instruction Manual IM-150
For Gas/Steam Turbine Tensioned Studs & Nuts

Detensioning (Stud removal)

- Loosen nuts' set screws
- Inspect and clean studs' conical threads. **Do not continue until ALL debris is removed from the threads!** Do not try to use the tensioner to remove a damaged stud!
- Apply a light coat of clean turbine oil or spray lubricant to the puller screw. **DO NOT USE "NEVER SEIZE" ON THE CONICAL THREADS.**
- Slide spanner ring over the puller screw.
- Mount the tensioner on the stud and install spanner ring into nut.
- Tighten the puller screw. Then back off puller screw 1/2 a turn.
- Retighten the puller screw and leave tight. **DO NOT BACK OFF PULLER SCREW.**
- Tighten puller nut and then back nut off two flats or 120 degrees to allow for stud stretch.
- Bleed the tensioner. **Do NOT bleed tensioner off of a stud! Damage to the tool will result!**
- Apply final pressure.
- Loosen nut with the spanner ring and pin wrench.
- Move to next stud in pattern



215 Clinton Road.
New Hartford, NY 13413
Tel: 315-768-4855
Fax: 315-768-4941
Email: info@riverhawk.com

GE DRAWING NUMBER	REV.
373A4006	D
FIRST MADE FOR:	SH.

4.0 General Preparations

Read and understand all instructions before installing and tensioning studs.

This equipment produces very high hydraulic pressures and very high forces. Operators must exercise caution, wear safety glasses and hard hats when using this equipment.

High-pressure fluid from the Hydraulic Pressure Kit system pressurizes the tensioner which generates a stretching force that actually stretches the stud. As the stud is stretched the nut lifts off the flange. The nut is then reseated into position on the flange by turning a nut driver by hand. When the nut is tight against the flange, the pressure in the tensioner is released leaving the stud loaded to its predetermined value.

4.1 Machine Preparation

The flange to be tensioned must be fully closed prior to positioning the studs in the flanges. There must be provisions for turning the shafts of the turbine, coupling, gearbox and generator. Also, it will be advantageous to remove as many obstructions as possible from the flange area, such as speed probes and conduit.

4.2 Hardware - Balance

- Hardware is supplied in weight balanced sets
- Studs and Nuts are interchangeable within sets
- Do not mix with other sets
- Save weight certification data supplied with each set for purchase of spares



215 Clinton Road.
New Hartford, NY 13413
Tel: 315-768-4855
Fax: 315-768-4941
Email: info@riverhawk.com

GE DRAWING NUMBER	REV.
373A4006	D
FIRST MADE FOR:	SH.

**Instruction Manual IM-150
For Gas/Steam Turbine Tensioned Studs & Nuts**

4.3 Tensioner - Care and Handling

- When not in use, the tensioner shall be maintained in a clean environment and all caps and plugs for hydraulic openings and fittings must be in place.
- When in use, the tensioner shall be protected from sand and grit
- Long term storage - coat tensioner with oil, return to original container, seal container and protect from moisture.
- Shipment - coat tensioner with oil and ship in original container

4.4 Hand Tools

Several hand wrenches and micrometers will be required to perform installation and measurement of the studs:

- 5/8" open end wrench
- 15/16" open-end wrench
- 1" wrench
- A set of Allen Wrenches
- 3' - 4' Breaker Bar
- 5" to 6" micrometer or caliper
- 6" to 7" micrometer or caliper

4.5 Special Tools

- Hydraulic Tensioner Kit:
- HT-2268 Hydraulic Tensioner, 1-5/8"
 - HT-2286 Hydraulic Tensioner, 1-1/8"
(reference GE 364B3422)
- Hydraulic Pump Kit:
- MP-0130 Manual Hand-Operated Hydraulic Pump
(recommended)
(reference GE 359B2506)
 - AP-0532 Air-Operated Hydraulic Pump
(reference GE 359B2502)



215 Clinton Road.
New Hartford, NY 13413
Tel: 315-768-4855
Fax: 315-768-4941
Email: info@riverhawk.com

GE DRAWING NUMBER	REV.
373A4006	D
FIRST MADE FOR:	SH.

5.0 Preparation of Hardware

5.1 Nut Preparation

For new installations the nuts should come sealed from the factory and will need no cleaning.

Previously installed nuts require cleaning as follows: Wire brush using a petroleum based solvent to remove any foreign material on the external surfaces and threads.

If previous installation employed a thread locking compound, which will be visible as a grayish-green residue, remove as much of this compound as possible.

Do not apply thread lubricants to the threads.

Finish the cleaning process by rinsing in a volatile solvent such as acetone and allow to dry.

5.2 Stud Preparation

Check the stud for any visible damage. If there is any visible damage, do not use the stud and contact the Riverhawk Company for a replacement stud. Please be prepared to supply the turbine number, weight certification, and digital photographs for evaluation.

The conical threads of each stud must be clean before installation or removal. This ensures the proper seating of the puller screw.

5.2.1 Stud Cleaning - New Installations

For new installations, the studs should come sealed from the factory and will need no cleaning.



215 Clinton Road.
New Hartford, NY 13413
Tel: 315-768-4855
Fax: 315-768-4941
Email: info@riverhawk.com

GE DRAWING NUMBER	REV.
373A4006	D
FIRST MADE FOR:	SH.

5.2.2 Stud Cleaning - Old Installations

Previously installed studs may require cleaning. Clean conical threads should have a bright and shiny appearance.

If cleaning is required, follow these steps:

1. Blow out the threads with compressed air to remove loose debris and dry conical threads. Do not apply a solvent or other cleaning solution to the threads as this may chemically attack the stud.
2. Use Stud Cleaning Kit, GT-4354 or a similar 1/2" diameter Brass power brush.



Picture of Brass Power Brush

3. Insert the brush into an electric drill and set drill to run in a counterclockwise direction at high speed.
4. Work the drill in a circular motion while moving the brush in and out to clean all of the threads. Try not to hold the brush in one place too long, so as not to remove the stud's protective coating.
5. Blow out the threads with compressed air to remove loosened debris.
6. Visually inspect threads for cleanliness. Threads should be bright and shiny.
7. Repeat if any dirt can be seen in the threads.
8. Inspect threads for any damage that may have been caused by previous installation.

Do not apply thread lubricants to the threads.

Finish the cleaning process by rinsing in a volatile solvent such as acetone and allow to dry.



215 Clinton Road.
New Hartford, NY 13413
Tel: 315-768-4855
Fax: 315-768-4941
Email: info@riverhawk.com

GE DRAWING NUMBER	REV.
373A4006	D
FIRST MADE FOR:	SH.

5.3 Stud Length Measurement

Measure and record the initial length of the studs. The following suggestions will improve your results:

- Plan to start and finish any flange in the same day.
- Studs and flange must be at the same temperature
- Number each stud with a marker.
- Mark the location of the measurement on stud end with a permanent marker.
- Measure each stud to nearest 0.001 inch.
- Record each measurement on the supplied charts.
- Do not allow the measuring instruments to set in the sun

6.0 Stud and Nut Assembly

Refer to the Hardware Assembly Drawing (HF-) listed in Section 2.0 of this manual. Assemble the cylindrical nut to the tapered thread end (Pull End) of the stud. Slide the stud and cylindrical nut assembly into the flange as shown in Figures 1, 2 & 3 and install the other nut on the backside. **Adjust nut/stud assembly so that the stud protrudes from the face of the cylindrical nut the amount depicted on the hardware drawing (HF-). SETTING THIS PROTRUSION OF STUD TO NUT IS CRITICAL FOR PROPER TENSIONER OPERATION.** Hand tighten the assembly to a snug fit.

7.0 Assembly of Hydraulic Tensioner Equipment

7.1 Kit Assembly

Assemble the hydraulic pump with its hose to the puller tool and bleed the system of air per following instructions.

7.1.1 Fittings

Make sure both male and female parts are clean and free of debris, see Figure 4 for fitting configuration. Hold female part securely when tightening so as to prevent damage to the adjacent tubing. If the fitting leaks first try retightening as needed. If leaking continues then disassemble and check for scratches or debris on the seating conical surfaces. Clean as required. Replace plastic protective caps when finished with the tooling.



215 Clinton Road.
New Hartford, NY 13413
Tel: 315-768-4855
Fax: 315-768-4941
Email: info@riverhawk.com

GE DRAWING NUMBER	REV.
373A4006	D
FIRST MADE FOR:	SH.

**Instruction Manual IM-150
For Gas/Steam Turbine Tensioned Studs & Nuts**

7.2 Pump

Pump kit is shipped full of hydraulic oil. The pump reservoir cap is sealed for shipment. To use turn cap to the vent position. To prevent oil spillage close cap when not in use, during storage and shipment. Lost oil should be replaced with Enerpac Hydraulic Oil. ISO 32 Mineral Oil may be substituted, if necessary.

7.3 Bleeding Hydraulic System

Follow the tensioner assembly instructions of Section 8.0.

TO AVOID FAILURE, ENSURE SAFETY AND PROPER OPERATION THE TENSIONER ASSEMBLY MUST BE MOUNTED ON THE STUD BEFORE BLEEDING THE SYSTEM AND TENSIONING BEGINS.

Mount tensioner on a stud per the assembly instructions of Section 8.0. Make sure the pump is situated below the tensioner assembly. The tensioner assembly has two ports, one for pressurizing and one for bleeding the system. These ports service a common chamber and therefore may be treated interchangeability. The bleed port must always be oriented in the uppermost position. The puller tool is shipped with a 5/8 in. [16 mm] hex coned stem bleeder fitting installed. With this fitting loosened stroke the pump repeatedly until the stream of oil exiting the tool is free of air then retighten the fitting.

Note: The hose is stiff, use of this tooling can be simplified by temporarily mounting the puller tool on one stud prior to final tightening of fittings. This will reduce the tendency for the fittings to loosen during use.



215 Clinton Road.
New Hartford, NY 13413
Tel: 315-768-4855
Fax: 315-768-4941
Email: info@riverhawk.com

GE DRAWING NUMBER	REV.
373A4006	D
FIRST MADE FOR:	SH.

8.0 Assembly of Tensioner on Stud

Two types of Tensioner Kits will be encountered in the field. The two assemblies are depicted in Figures 5 & 6.

Clean puller screw and check for any debris and dents.

Puller screw should be free to rotate and move back and forth.

Inspect tensioner guard for any signs of damage. Bent guards should be replaced.

All tensioning (pulling) will be performed from the tapered thread end of the stud with orientation of the stud to the flange as shown in Figures 1, 2, & 3

8.1 Assembly of Tensioner Kit with Integral Safety Cage.

Refer to Tensioner Assembly drawing and Figure 5 for tensioner to flange mounting. This assembly has the following features which should make stud tensioning safer and easier.

- The safety cage is integral (bolted) to the puller tool
- The hydraulic piston is spring loaded to retract
- The puller screw is a 2-piece design, This requires that the operator tighten the puller screw into the stud and then install a puller nut.

Assembly sequence is as follows:

- **Open the hydraulic return valve on the pump to allow hydraulic fluid to be pushed back from the puller tool into the pump reservoir. (This is automatic with the air-operated hydraulic pump)**
- Place the spanner ring on the puller side cylindrical nut.
- Apply a light coat of clean turbine oil or a spray lubricant to the puller screw. Do not use "Never Seize" on the conical threads.
- Place and hold the puller tool over the end to be tightened.
- Insert the puller screw through the puller tool into the tapered thread of the stud and tighten.
- **Be sure not to cross-thread the assembly.**
- Tighten the puller screw using Allen wrenches on the puller screw and the stud. DO NOT wrench on the Hex nut opposite the puller tool.



215 Clinton Road.
New Hartford, NY 13413
Tel: 315-768-4855
Fax: 315-768-4941
Email: info@riverhawk.com

GE DRAWING NUMBER	REV.
373A4006	D
FIRST MADE FOR:	SH.

**Instruction Manual IM-150
For Gas/Steam Turbine Tensioned Studs & Nuts**

- Install the puller nut until it seats snugly on the piston and then back-off 2 flats. This is particularly important for removal because the stud shortens during disassembly and the tensioner may then bind.
- At this point the Tensioner Assembly **MUST BE FREE TO ROTATE**, the puller screw is tight in the stud and the puller nut has been backed-off the 2 flats.

Note: If the tool is not free to rotate it is most likely that the nuts must be repositioned so that the stud may be shifted slightly to the puller tool side of the flange. This can be accomplished as follows:

- Back off the puller nut and slightly loosen the puller screw.
- Back off the Hex nut opposite the puller tool about 1 /2 turn.
- Tighten the puller screw side cylindrical nut to take up the slack
- Retighten the puller screw per above and check for tool looseness

Note: Do not over extend the stud. Over extension can cause the piston to lose its seal and leak oil.

CAUTION

Personal injury and equipment damage can occur if the puller screw is not securely engaged with the tapered threads of the stud. Proper engagement is achieved when the puller screw is tight in the stud and the tensioner assembly is free to turn.



215 Clinton Road.
New Hartford, NY 13413
Tel: 315-768-4855
Fax: 315-768-4941
Email: info@riverhawk.com

GE DRAWING NUMBER	REV.
373A4006	D
FIRST MADE FOR:	SH.

9.0 Stud Pulling and Tensioning

The studs will be tensioned in two steps, at approximately 50% pressure and at final pressure. Follow the tensioning sequence for each flange joint as defined on the data sheets found at the end of this manual.

Note: Before threading the puller screw into the stud, carefully check the cleanliness of both the stud's and the puller screw's conical threads. Apply a light coat of clean turbine oil or a spray lubricant to the puller screw. Do not use "Never Seize" on the conical threads. This procedure will ease assembly and assure positive mating of the threads before tightening.

WARNING

The safety cage MUST be in place and hands kept out of designated areas at all times when the puller tool is pressurized otherwise personal injury can occur.

9.1 Tensioning at 50% pressure

After the tensioner is properly installed apply hydraulic pressure to the tool. Bring the pressure to the 50% level in accordance with the following table.

<u>Flange Position</u>	<u>Stud Size</u>	<u>50% Pressure</u>	<u>50% Stretch</u>
Turbine to Coupling	1-1/8" [29 mm]	9000 psi [620 bar]	Do not measure Do not use
Coupling to Gear	1-1/8" [29 mm]	9000 psi [620 bar]	Do not measure Do not use
Gear to Quill Shaft	1-5/8" [41 mm]	7500 psi [520 bar]	Do not measure Do not use
Quill Shaft to Generator	1-5/8" [41 mm]	7500 psi [520 bar]	Do not measure Do not use

9.1.1 Tightening of 1-1/8" Nuts

Tighten the cylindrical nuts hand tight using the pin wrench and spanner ring (see figure 5).



215 Clinton Road.
New Hartford, NY 13413
Tel: 315-768-4855
Fax: 315-768-4941
Email: info@riverhawk.com

GE DRAWING NUMBER	REV.
373A4006	D
FIRST MADE FOR:	SH.

**Instruction Manual IM-150
For Gas/Steam Turbine Tensioned Studs & Nuts**

9.1.2 Tightening of 1-5/8" Nuts

Tighten the cylindrical nuts hand tight using the pin wrench and spanner ring (see figure 6).

9.2 Removing the Tensioner from an Installed Stud

Puller tool removal is to be accomplished as follows:

- Release the puller tool pressure by opening the valve on the pump. Leave valve open. (This is automatic with the air-operated hydraulic pump)
- Unscrew the puller screw using a wrench.
- Tapping the wrench with a hammer may be necessary to loosen the puller screw
- Move the tool to the next stud/nut assembly to be tensioned, following the sequence/pattern as defined on the supplied data sheets

9.3 Tensioning at Final Pressure

Repeat the pulling and tightening procedure stated above at full pressure. Measures the length of the studs after all have been tensioned. The final pressure and required stretch values are listed in the following table

<u>Flange Position</u>	<u>Stud Size</u>	<u>Final Pressure</u>	<u>Final Stretch</u>
Turbine to Coupling	1-1/8" [29 mm]	18000 psi [1250 bar]	0.009" - 0.011" [0.23 mm - 0.28 mm]
Coupling to Gear	1-1/8" [29 mm]	18000 psi [1250 bar]	0.008" - 0.010" [0.20 mm - 0.25 mm]
Gear to Quill Shaft	1-5/8" [41 mm]	15000 psi [1035 bar]	0.007" - 0.009" [0.18 mm - 0.23 mm]
Quill Shaft to Generator	1-5/8" [41 mm]	15000 psi [1035 bar]	0.007" - 0.009" [0.18 mm - 0.23 mm]

CAUTION

DO NOT EXCEED THE MAXIMUM PRESSURE VIBROSCRIBED ON THE PULLER BODY. Excessive pressure can damage the stud and the puller screw.



215 Clinton Road.
New Hartford, NY 13413
Tel: 315-768-4855
Fax: 315-768-4941
Email: info@riverhawk.com

GE DRAWING NUMBER	REV.
373A4006	D
FIRST MADE FOR:	SH.

**Instruction Manual IM-150
For Gas/Steam Turbine Tensioned Studs & Nuts**

10.0 Retensioning

Excessive stretch variations or low stretch values can be corrected by retensioning all or selected studs to the pressure values stated in the above table. Have final stretch values approved by the supervisor responsible for the installation

11.0 Thread Locking

Mechanical lock nuts have two set screws located in the top face, see Figure 7. Before threading the nut onto the stud check to be certain the set screws are free to turn. Once the nut is seated torque the set screws to the values specified in the following table. When seated and torqued to the values specified the load created by the set screw displaces the thread of the nut in the area of the web creating the desired locking action.

<u>Stud Size</u>	<u>Set Screw Size</u>	<u>Torque</u>
1-1/8" [29 mm]	#10-32 UN	30 in·lbs - 36 in·lbs [3.4 N·m - 4.1 N·m]
1-5/8" [41 mm]	1/4"-28 UN	65 in·lbs - 87 in·lbs [7.3 N·m - 9.8 N·m]

CAUTION :

DO NOT EXCEED THE MAXIMUM PRESSURE VIBROSCRIBED ON THE PULLER BODY. Excessive pressure can damage the stud and the puller screw.

WARNING:

Fire Hazard, DO NOT heat when puller assembly is in place. Personal injury or equipment damage may occur. Use of an Oxy-Acetylene torch is not recommended



215 Clinton Road.
New Hartford, NY 13413
Tel: 315-768-4855
Fax: 315-768-4941
Email: info@riverhawk.com

GE DRAWING NUMBER	REV.
373A4006	D
FIRST MADE FOR:	SH.

12.0 Stud/Nut removal

For those assemblies which have been locked using mechanical lock nuts, removal is accomplished as follows:

- Using a wire brush and shop air clean the internal tapered thread of the stud to remove any debris/deposits which may have accumulated during service. (see section 5.2.1)
- With an Allen-wrench loosen the two locking set screws but do not remove from nut see Figure 5.
- Install the appropriate puller tool to the stud as described in Section 8.0.
- Apply the appropriate hydraulic pressure per the table of Section 9.3 and using the spanner ring and spanner wrenches shown in Figure 6 loosen the nut, then release the pressure and remove the puller tool.



215 Clinton Road.
New Hartford, NY 13413
Tel: 315-768-4855
Fax: 315-768-4941
Email: info@riverhawk.com

GE DRAWING NUMBER	REV.
373A4006	D
FIRST MADE FOR:	SH.

**Instruction Manual IM-150
For Gas/Steam Turbine Tensioned Studs & Nuts**

13.0 Frequently Asked Questions

This section contains some frequently asked questions and problems. If the steps listed here do not solve your problem, contact the Riverhawk Company thru our website, email, or phone call.

Q: A tensioner has pulled itself out of the stud's conical threads. Can I continue using a tensioner on this stud?

A: No. Both the tensioner and the stud may have been damaged. If the stud is tensioned, a Nut Buster repair kit, from Riverhawk, must be used to remove the damaged stud by drilling out the nut. Riverhawk can supply a replacement stud and nut based on the initial weight certification supplied with the hardware set (see section 4.2). The damaged tensioner should also be returned to Riverhawk for inspection and repair.

Q: The hydraulic tensioner has been taken up to its final pressure. The final stretch length is short of the final stretch target. What is the next step?

A: Do not increase the hydraulic pressure. Check if the hydraulic pump is set to the right pressure. Install the tensioner and re-pressurize the tensioner to the final pressure then recheck the stretch measurement. If the stretch value is still short, remove the stud from the hole and re-measure the stud's initial length then try to install the stud again.

Q: The hydraulic tensioner has been taken up to its final pressure. The final stretch length is larger than the final stretch target. What is the next step?

A: Remove the stud from the bolt hole. Check if the hydraulic pump is set to the right pressure. Re-measure the stud's initial length then try to install the stud again.



215 Clinton Road.
New Hartford, NY 13413
Tel: 315-768-4855
Fax: 315-768-4941
Email: info@riverhawk.com

GE DRAWING NUMBER	REV.
373A4006	D
FIRST MADE FOR:	SH.

**Instruction Manual IM-150
For Gas/Steam Turbine Tensioned Studs & Nuts**

- Q:** Is there an easier way to support or move the tensioner around the coupling shaft?
- A:** Use two straps. One around the coupling shaft and the other attach to any overhead support. Straps must be slack during mounting tensioner to stud and during tensioning.
- Q:** The tensioner is at its final pressure, but the nut cannot be loosen.
- A:** If the nuts cannot be loosened at the final pressure, continually increasing the pressure will not help and can be dangerous and in some cases make it harder to remove the nut. Check the nut to see if its set screws have been loosened. Check for and remove any corrosion around the nut's threads.
- Q:** How do I clean the conical threads on a stud?
- A:** The conical threads are best cleaned using a spiral wound brass brush in a drill as described in section 5.2.2
- Q:** During the initial steps of removing a tensioned stud, the stick-out length is found to be wrong.
- A:** Do not proceed. Contact Riverhawk for assistance. With the wrong stick-out length, the hydraulic tensioner has a limited stroke and may not work properly and can be damaged.
- Q:** The hydraulic pump appears to be leaking.
- A:** Check the hose connection to the hydraulic pump. If the 1/4" high pressure fitting is not assembled correctly, it may look like the pump is leaking. If the problem continues, it may be necessary to open the pump kit. Contact Riverhawk for guidance.



215 Clinton Road.
New Hartford, NY 13413
Tel: 315-768-4855
Fax: 315-768-4941
Email: info@riverhawk.com

GE DRAWING NUMBER	REV.
373A4006	D
FIRST MADE FOR:	SH.

**Instruction Manual IM-150
For Gas/Steam Turbine Tensioned Studs & Nuts**

Q: The hydraulic hose has a collar on it that can't be moved by hand

A: The hydraulic fitting is shown in section 7.1.1. The collar is sometimes held in place with a thread locking compound. This prevents the collar from moving too easily. It may be necessary to adjust this collar with a set of vise-grip pliers. Be careful to not strip the threads off the tube or hose end.



215 Clinton Road.
New Hartford, NY 13413
Tel: 315-768-4855
Fax: 315-768-4941
Email: info@riverhawk.com

GE DRAWING NUMBER	REV.
373A4006	D
FIRST MADE FOR:	SH.

**Instruction Manual IM-150
For Gas/Steam Turbine Tensioned Studs & Nuts**

14.0 Revision History

Revision Letter	Effective Date	Description
D	Jun 10, 2009	Added turbine oil and removed "Never Seize" from sections 1.0, 3.0, 8.0, and 9.0
C	Mar 25, 2009	Added sections 3 and 13
B	Sept 19, 2003	Added GE 382A4352 and HF-2312
A	Sept 10, 2003	Drawings
-	Aug 11, 2003	Released



215 Clinton Road.
New Hartford, NY 13413
Tel: 315-768-4855
Fax: 315-768-4941
Email: info@riverhawk.com

GE DRAWING NUMBER	REV.
373A4006	D
FIRST MADE FOR:	SH.

Instruction Manual IM-150
 For Gas/Steam Turbine Tensioned Studs & Nuts

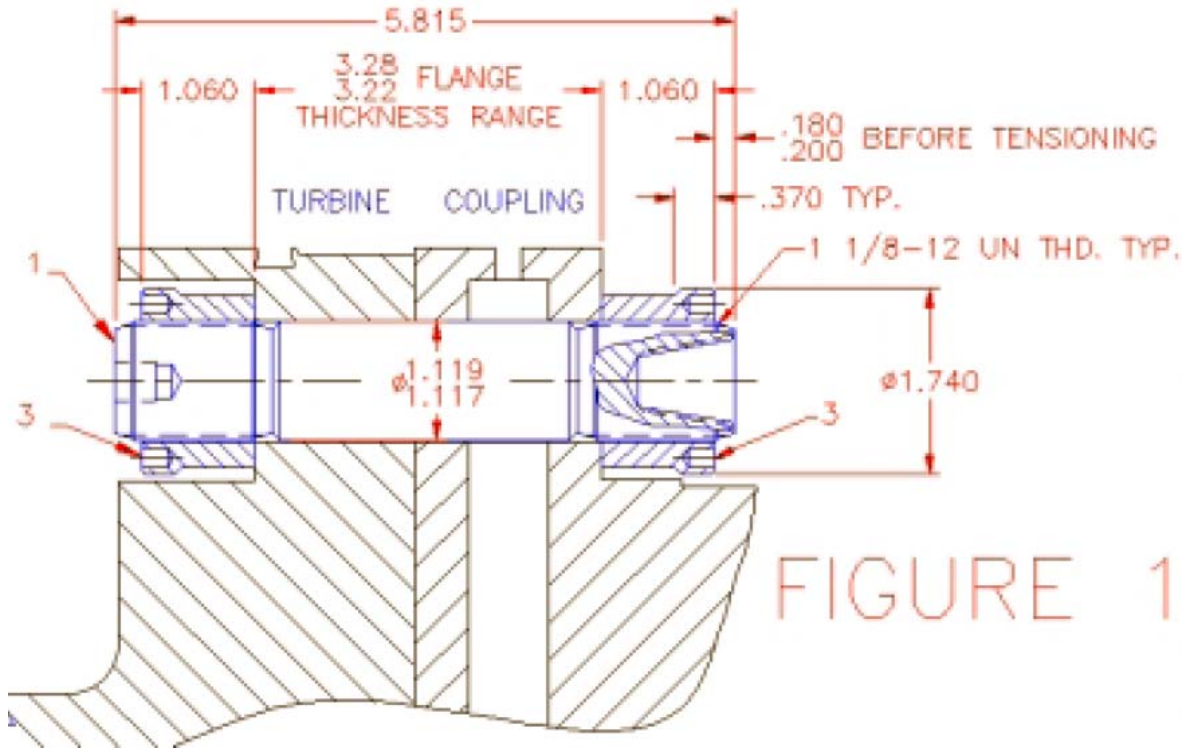

FIGURE 1

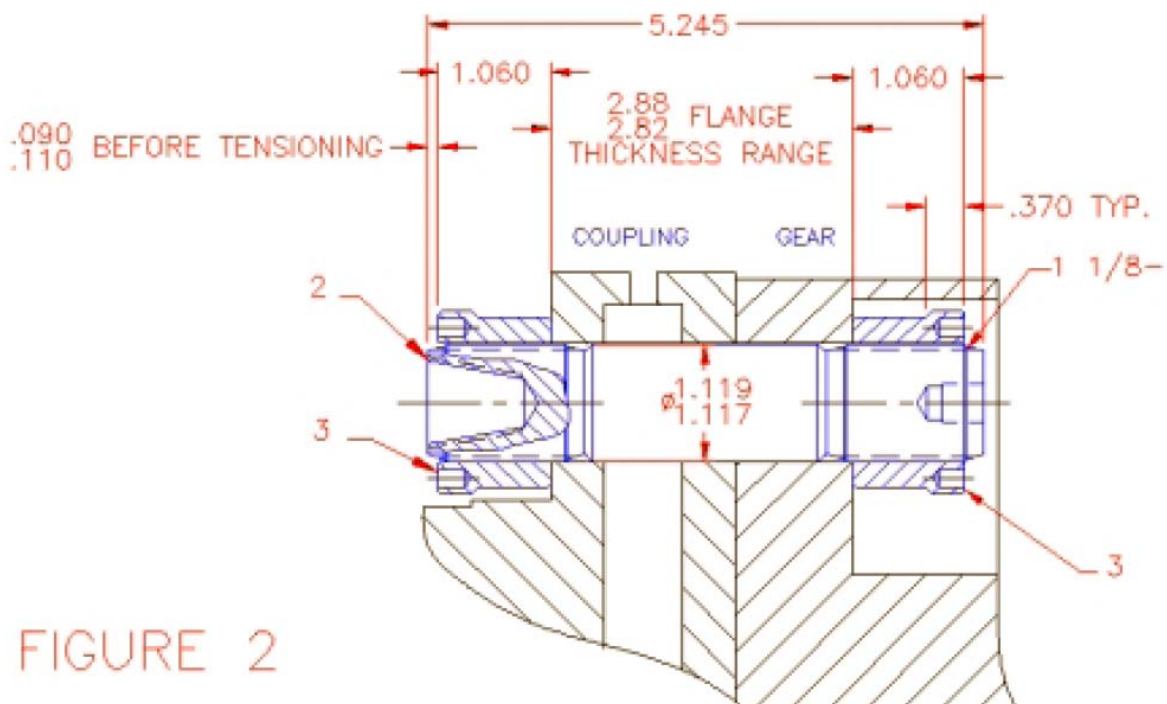

FIGURE 2



215 Clinton Road.
 New Hartford, NY 13413
 Tel: 315-768-4855
 Fax: 315-768-4941
 Email: info@riverhawk.com

GE DRAWING NUMBER	REV.
373A4006	D
FIRST MADE FOR:	SH.

Instruction Manual IM-150
 For Gas/Steam Turbine Tensioned Studs & Nuts

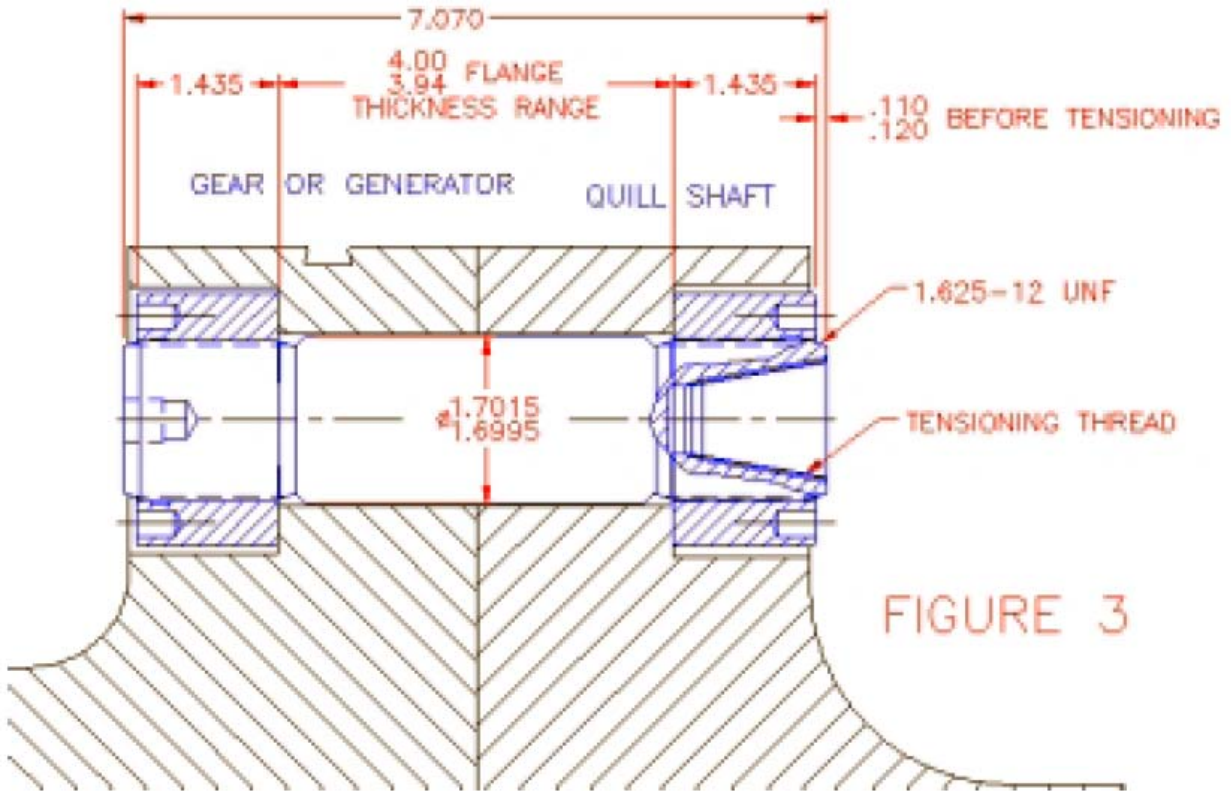
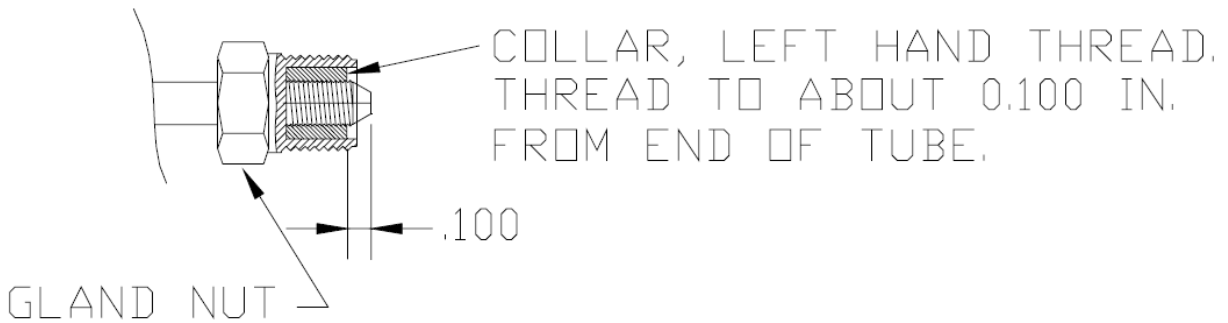

FIGURE 4 PRESURE PORT



215 Clinton Road.
 New Hartford, NY 13413
 Tel: 315-768-4855
 Fax: 315-768-4941
 Email: info@riverhawk.com

GE DRAWING NUMBER	REV.
373A4006	D
FIRST MADE FOR:	SH.

**Instruction Manual IM-150
For Gas/Steam Turbine Tensioned Studs & Nuts**

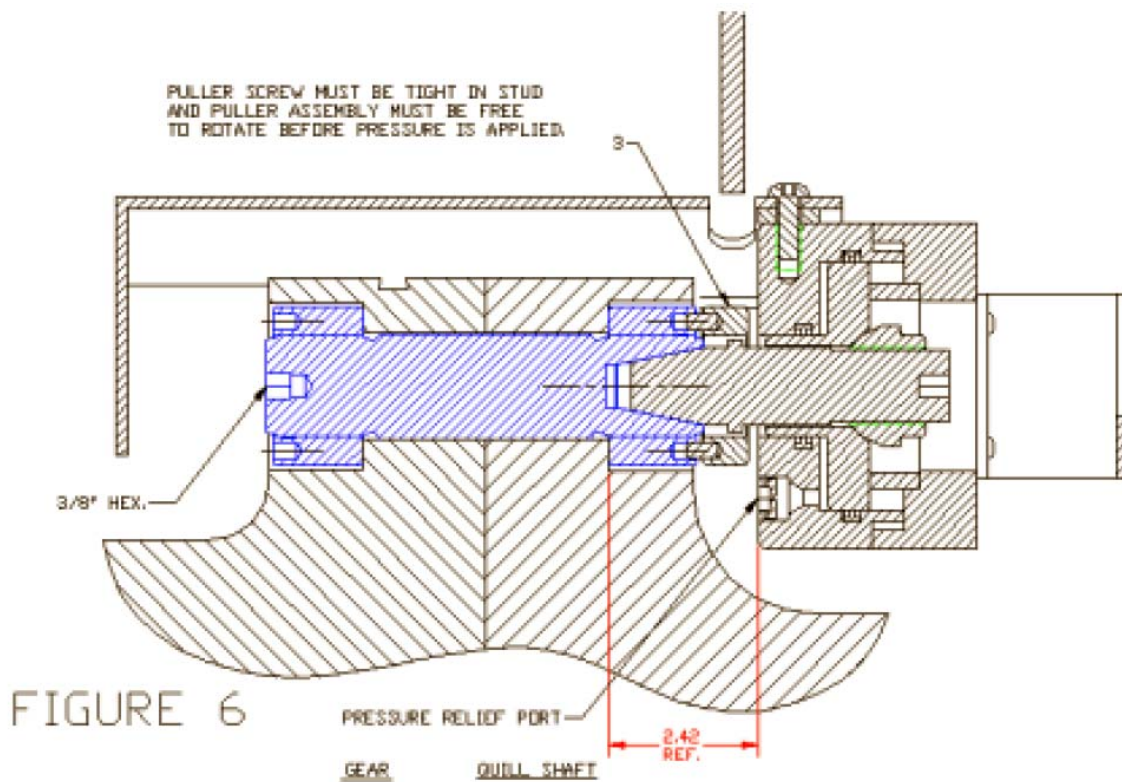
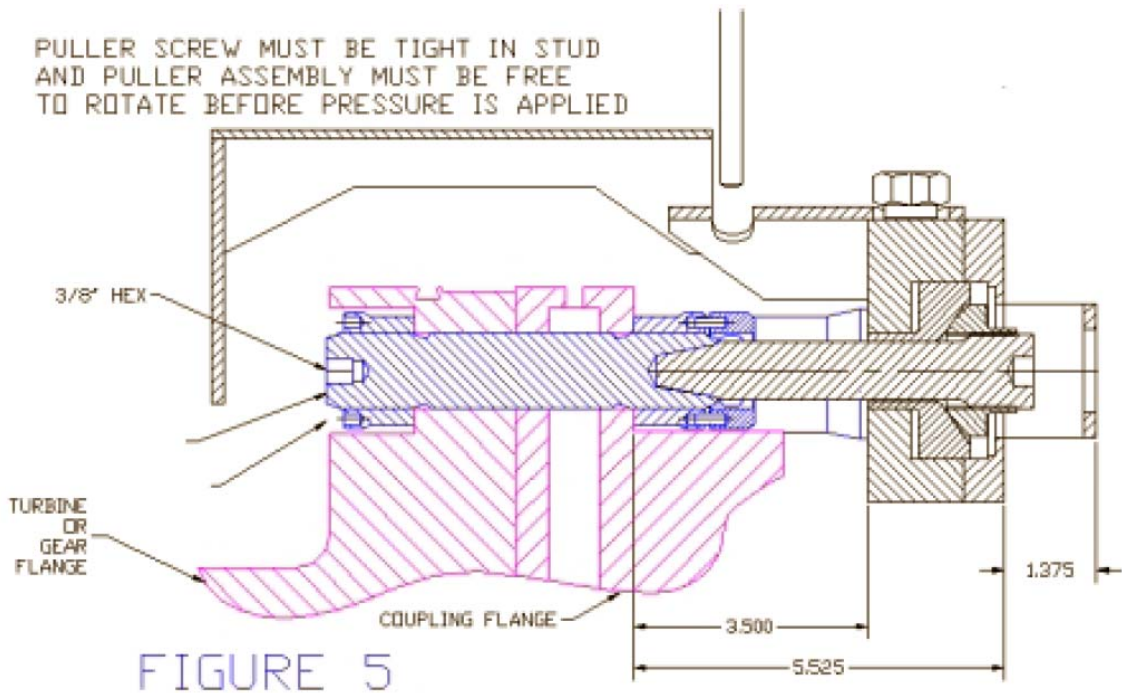

215 Clinton Road.
New Hartford, NY 13413
Tel: 315-768-4855
Fax: 315-768-4941
Email: info@riverhawk.com

GE DRAWING NUMBER	REV.
373A4006	D
FIRST MADE FOR:	SH.

Instruction Manual IM-150
For Gas/Steam Turbine Tensioned Studs & Nuts

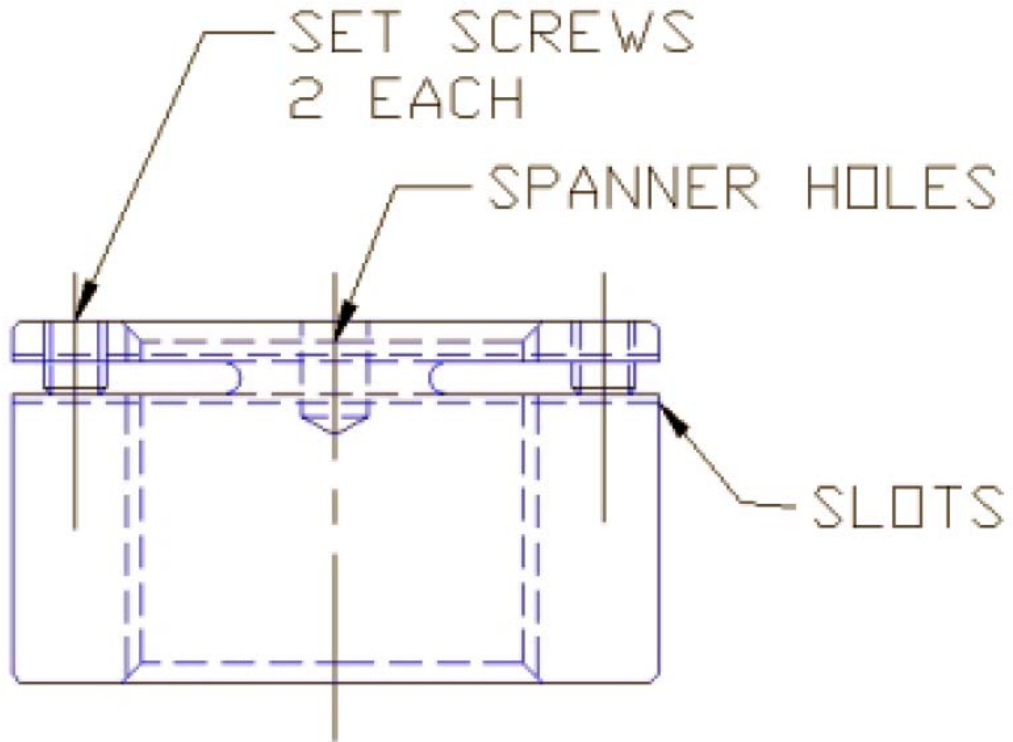

FIGURE 7



215 Clinton Road.
New Hartford, NY 13413
Tel: 315-768-4855
Fax: 315-768-4941
Email: info@riverhawk.com

GE DRAWING NUMBER	REV.
373A4006	D
FIRST MADE FOR:	SH.

Instruction Manual IM-150
For Gas/Steam Turbine Tensioned Studs & Nuts

Photo 1
**Looking down on gear to generator
flange of 6FA machine.
Shows 2" puller tool
mounted with safety cage in**

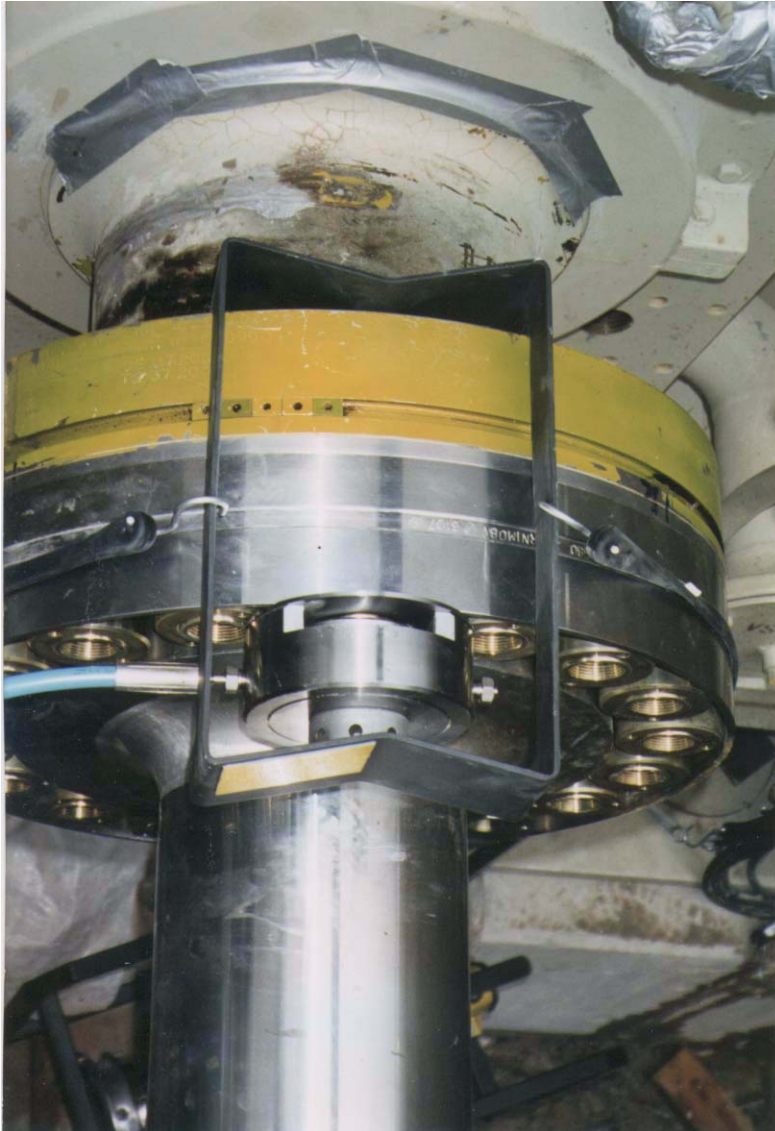

215 Clinton Road.
New Hartford, NY 13413
Tel: 315-768-4855
Fax: 315-768-4941
Email: info@riverhawk.com

GE DRAWING NUMBER	REV.
373A4006	D
FIRST MADE FOR:	SH.

Instruction Manual IM-150
For Gas/Steam Turbine Tensioned Studs & Nuts

Photo 2
Side view of 2" puller tool
and safety cage on 6FA
machine.

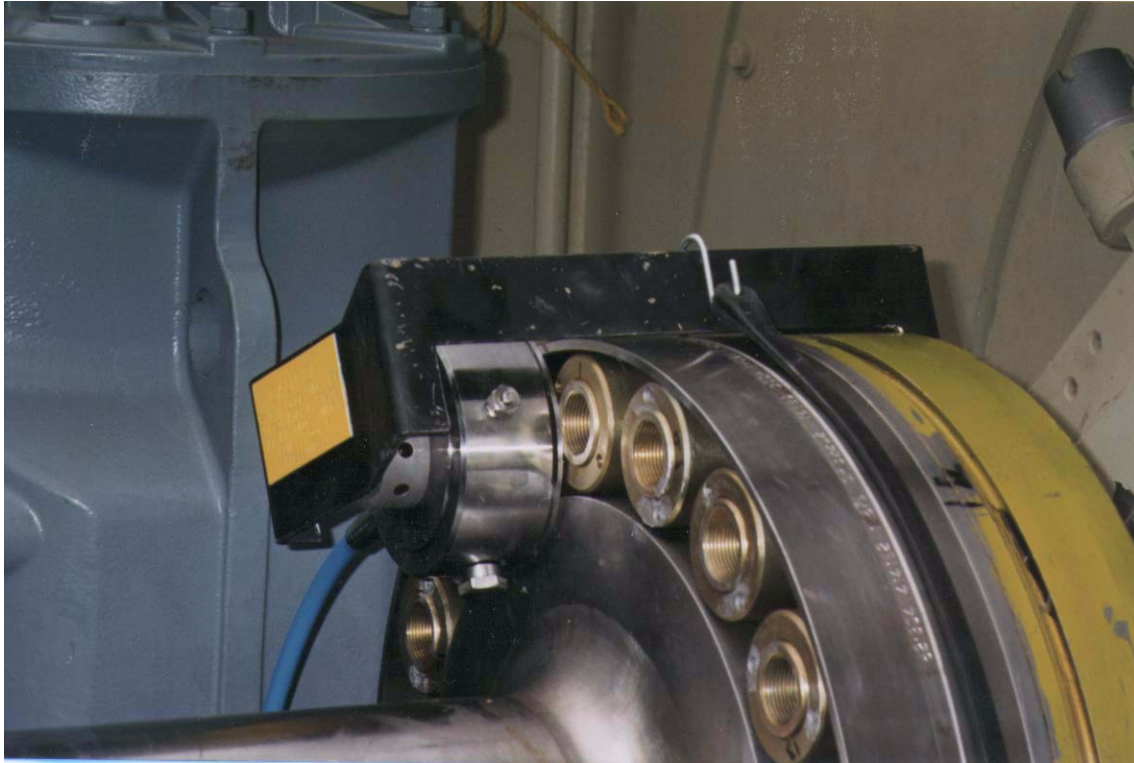

215 Clinton Road.
New Hartford, NY 13413
Tel: 315-768-4855
Fax: 315-768-4941
Email: info@riverhawk.com

GE DRAWING NUMBER	REV.
373A4006	D
FIRST MADE FOR:	SH.

Instruction Manual IM-150
For Gas/Steam Turbine Tensioned Studs & Nuts

Photo 3 Top view of 1 1/8" puller tool and safety cage in place. Tool is mounted on coupling to gear flange of 6FA machine.

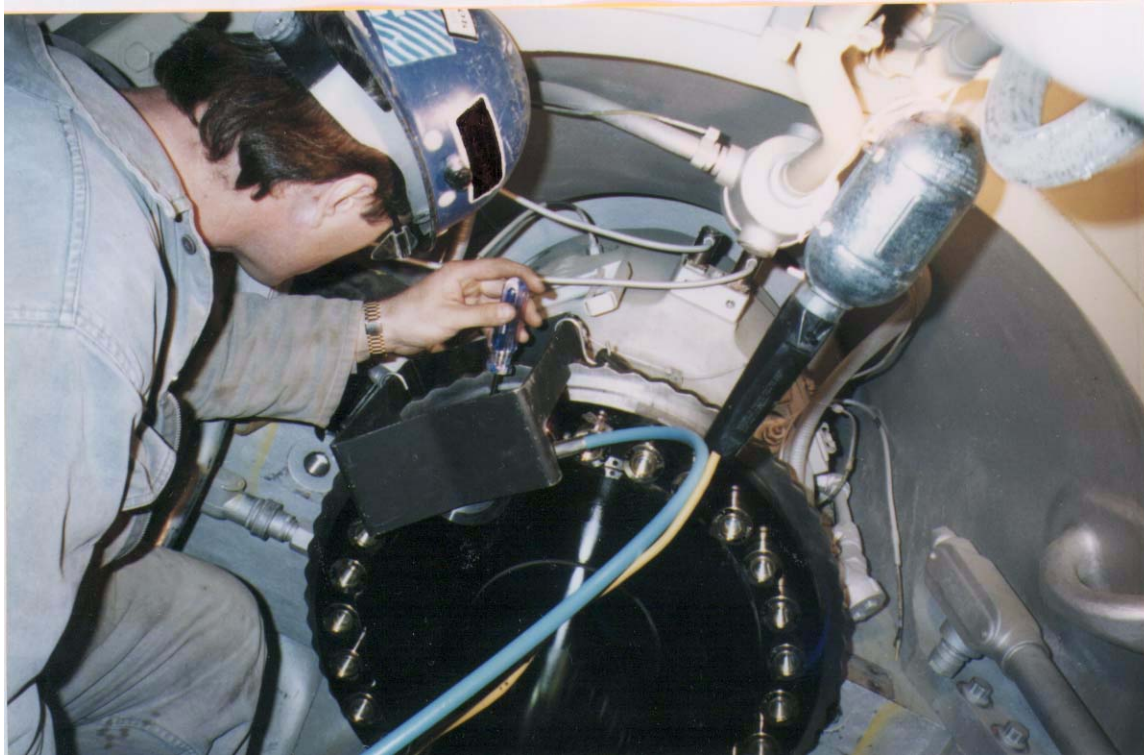

215 Clinton Road.
New Hartford, NY 13413
Tel: 315-768-4855
Fax: 315-768-4941
Email: info@riverhawk.com

GE DRAWING NUMBER	REV.
373A4006	D
FIRST MADE FOR:	SH.

Instruction Manual IM-150
For Gas/Steam Turbine Tensioned Studs & Nuts

Photo 4
View of 1 1/8 puller tool and
safety cage mounted
on turbine to
coupling flange of
6FA machine. Tool is



215 Clinton Road.
New Hartford, NY 13413
Tel: 315-768-4855
Fax: 315-768-4941
Email: info@riverhawk.com

GE DRAWING NUMBER	REV.
373A4006	D
FIRST MADE FOR:	SH.

Instruction Manual IM-150
For Gas/Steam Turbine Tensioned Studs & Nuts

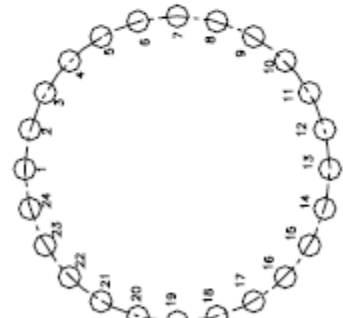
4	3	2	1
D	C	B	A
<p>STRETCH RECORD SHEET FOR (24) STUD PATTERN</p>			
			
<p>MACHINE _____ FLANGE _____ DATE _____ TECHNICIAN _____ SUPERVISOR _____</p>			
STUD LOCATION	ORIGINAL LENGTH	FIRST PULL LENGTH (1) STRETCH (1)	SECOND PULL LENGTH (2) STRETCH (2)
1	-----	-----	-----
2	-----	-----	-----
3	-----	-----	-----
4	-----	-----	-----
5	-----	-----	-----
6	-----	-----	-----
7	-----	-----	-----
8	-----	-----	-----
9	-----	-----	-----
10	-----	-----	-----
11	-----	-----	-----
12	-----	-----	-----
13	-----	-----	-----
14	-----	-----	-----
15	-----	-----	-----
16	-----	-----	-----
17	-----	-----	-----
18	-----	-----	-----
19	-----	-----	-----
20	-----	-----	-----
21	-----	-----	-----
22	-----	-----	-----
23	-----	-----	-----
24	-----	-----	-----
	AVG. STRETCH	-----	AVG. STRETCH
		-----	FINAL
UNITS in. mm, CIRCLE ONE			
<p>GE DRAWING NUMBER</p> <p align="center">373A4006</p>		<p>REV.</p> <p align="center">D</p>	
<p>FIRST MADE FOR:</p>		<p>SH.</p>	



215 Clinton Road.
 New Hartford, NY 13413
 Tel: 315-768-4855
 Fax: 315-768-4941
 Email: info@riverhawk.com

<p>GE DRAWING NUMBER</p> <p align="center">373A4006</p>	<p>REV.</p> <p align="center">D</p>
<p>FIRST MADE FOR:</p>	<p>SH.</p>

Instruction Manual IM-150
For Gas/Steam Turbine Tensioned Studs & Nuts

STRETCH RECORD SHEET FOR (24) STUD PATTERN

STUD LOCATION	ORIGINAL LENGTH	FIRST PULL		SECOND PULL	
		LENGTH (1)	STRETCH (1)	LENGTH (2)	STRETCH(2)
1	-----	-----	-----	-----	-----
2	-----	-----	-----	-----	-----
3	-----	-----	-----	-----	-----
4	-----	-----	-----	-----	-----
5	-----	-----	-----	-----	-----
6	-----	-----	-----	-----	-----
7	-----	-----	-----	-----	-----
8	-----	-----	-----	-----	-----
9	-----	-----	-----	-----	-----
10	-----	-----	-----	-----	-----
11	-----	-----	-----	-----	-----
12	-----	-----	-----	-----	-----
13	-----	-----	-----	-----	-----
14	-----	-----	-----	-----	-----
15	-----	-----	-----	-----	-----
16	-----	-----	-----	-----	-----
17	-----	-----	-----	-----	-----
18	-----	-----	-----	-----	-----
19	-----	-----	-----	-----	-----
20	-----	-----	-----	-----	-----
21	-----	-----	-----	-----	-----
22	-----	-----	-----	-----	-----
23	-----	-----	-----	-----	-----
24	-----	-----	-----	-----	-----
		AVG. STRETCH	-----	AVG. STRETCH	-----
				FINAL	-----

MACHINE _____
 FLANGE _____
 DATE _____
 TECHNICIAN _____
 SUPERVISOR _____

UNITS in. mm, CIRCLE ONE



215 Clinton Road.
New Hartford, NY 13413
Tel: 315-768-4855
Fax: 315-768-4941
Email: info@riverhawk.com

GE DRAWING NUMBER	REV.
373A4006	D
FIRST MADE FOR:	SH.

**Instruction Manual IM-150
For Gas/Steam Turbine Tensioned Studs & Nuts**

REV.	BY	DATE	REVISION	SCALE	DRAWN
A		11/26/98	SCALE CHANGT LARGER		

STUD LOCATION	ORIGINAL LENGTH	FIRST PULL LENGTH (1) STRETCH (1)	SECOND PULL LENGTH (2) STRETCH(2)	AVG. STRETCH	AVG. STRETCH FINAL
1	---	---	---	---	---
2	---	---	---	---	---
3	---	---	---	---	---
4	---	---	---	---	---
5	---	---	---	---	---
6	---	---	---	---	---
7	---	---	---	---	---
8	---	---	---	---	---
9	---	---	---	---	---
10	---	---	---	---	---
11	---	---	---	---	---
12	---	---	---	---	---
13	---	---	---	---	---
14	---	---	---	---	---
15	---	---	---	---	---
16	---	---	---	---	---
17	---	---	---	---	---
18	---	---	---	---	---
19	---	---	---	---	---
20	---	---	---	---	---

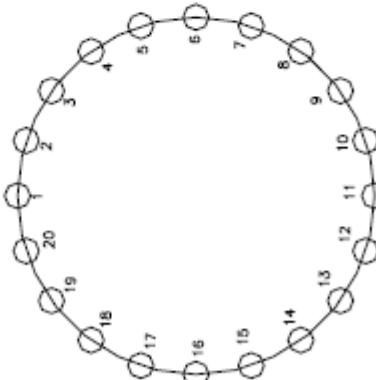

MACHINE _____

FLANGE _____

DATE _____

TECHNICIAN _____

SUPERVISOR _____

UNITS in. mm, CIRCLE ONE

Riverhawk Company 215 Clinton Road, New Hartford, NY	
DATE: 02/18/98	REV: C
TIGHTENING PATTERN FOR (20) STUDS	
960716-002 A	

GE DRAWING NUMBER	REV.
373A4006	D
FIRST MADE FOR:	SH.

Instruction Manual IM-150
 For Gas/Steam Turbine Tensioned Studs & Nuts

DATE	REV.	DESCRIPTION	DATE	REV.	DESCRIPTION
	A	SCALE CHART LARGER	11/25/90		MMR

MATERIAL:		Riverhawk <small>Company</small>	<small>2416 W. Whitehouse Rd., Union, N.Y.</small>
DATE:	07/18/96		
DWG. NO.:	373A4006		
REV. NO.:	C		
REV. DATE:	11/25/90		
REV. BY:	MMR		
REV. CHECKED:			
TIGHTENING PATTERN FOR (20) STUDS			
960716-002 A			

STUD LOCATION	ORIGINAL LENGTH	FIRST PULL LENGTH (1) STRETCH (1)	SECOND PULL LENGTH (2) STRETCH(2)	AVG. STRETCH	AVG. STRETCH FINAL
1					
11					
2					
12					
3					
13					
4					
14					
5					
15					
6					
16					
7					
17					
8					
18					
9					
19					
10					
20					

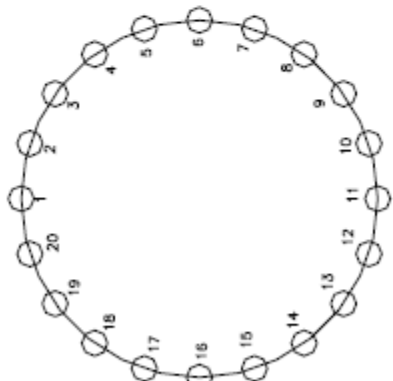

MACHINE _____

FLANGE _____

DATE _____

TECHNICIAN _____

SUPERVISOR _____

UNITS in. mm, CIRCLE ONE



215 Clinton Road.
 New Hartford, NY 13413
 Tel: 315-768-4855
 Fax: 315-768-4941
 Email: info@riverhawk.com

GE DRAWING NUMBER	REV.
373A4006	D
FIRST MADE FOR:	SH.