

REVISION LETTER	GE ALTERATION NOTICE NUMBER

**INSTRUCTION MANUAL IM-101  
For Gas and Steam Turbine Tensioned Studs and Nuts**

**Fr.6FA Turbine to 6FA Generator GE 356A3954P001**

**Steam Turbine to 6FA Generator GE 361A6147P001**

**Fr.6FA Turbine to 9A4 Elin Generator GE 356A3954P003**

**Steam Turbine to 9A4 Elin Generator**

GE Power Generation		GENERAL ELECTRIC COMPANY Schenectady, NY	
<b><u>VENDOR SUPPLIED DRAWING</u></b>			
GE NOT TO REVISE. GE REVISION LEVEL IS AS SHOWN ON THIS APPLIQUE. THIS DOCUMENT IS FILED UNDER THE GE DRAWING NUMBER			
THIS DOCUMENT SHALL BE REVISED IN ITS ENTIRETY. ALL SHEETS OF THIS DOCUMENT ARE THE SAME REVISION LEVEL AS INDICATED IN THIS VENDOR SUPPLIED DRAWING APPLIQUE			
FIRST MADE FOR:		___ OF ___	
GE SIGNATURES	DATE	GE DRAWING NUMBER	REV
CHECKED		373A4008	S
ISSUED			

The Riverhawk Company reserves the right to make changes updating this document without dissemination or notice. The latest revision level may be obtained by contacting Riverhawk Company directly or visit our website at [www.riverhawk.com](http://www.riverhawk.com)



215 Clinton Road.  
New Hartford, NY 13413  
Tel: 315-768-4855  
Fax: 315-768-4941  
Email: [info@riverhawk.com](mailto:info@riverhawk.com)

**Instruction Manual IM-101  
For Gas and Steam Turbine Tensioned Studs & Nuts**

**Table of Contents**

Section	Description	Page Number
1.0	Cautions and Safety Warnings	3
2.0	Scope	4
3.0	Quick Check-List	5
4.0	General Preparations	8
5.0	Hardware Set Preparations	11
6.0	Stud and Nut Assembly	13
7.0	Assembly of Hydraulic Tensioner Equipment	13
8.0	Assembly of Tensioner on Stud	16
9.0	Stud Pulling and Tensioning	19
10.0	Retensioning	22
11.0	Thread Locking	22
12.0	Stud/Nut Removal	23
13.0	Frequently Asked Questions	25
14.0	Revision History	28



215 Clinton Road.  
New Hartford, NY 13413  
Tel: 315-768-4855  
Fax: 315-768-4941  
Email: info@riverhawk.com

GE DRAWING NUMBER	REV.
373A4008	S
FIRST MADE FOR:	SH.

## 1.0 Cautions and Safety Warnings

**TO AVOID FAILURE, ENSURE SAFETY AND PROPER OPERATION THE TENSIONER ASSEMBLY MUST BE MOUNTED ON THE STUD BEFORE BLEEDING THE SYSTEM AND TENSIONING BEGINS. DO NOT USE THE TENSIONER ASSEMBLY AT ANY PRESSURE UNLESS THE TOOL IS MOUNTED ON THE STUD.**

**Note:** Do not over extend the stud. Over extension can cause the piston to lose it's seal and leak oil.

### CAUTION

Personal injury and equipment damage can occur if the puller screw is not securely engaged with the tapered thread of the stud. Proper engagement is achieved when the puller screw is tight in the stud and the Tensioner Assembly is free to rotate.

**TO AVOID FAILURE, ENSURE SAFETY AND PROPER OPERATION THE TENSIONER ASSEMBLY MUST BE MOUNTED ON THE STUD BEFORE BLEEDING THE SYSTEM AND TENSIONING BEGINS. DO NOT USE THE TENSIONER ASSEMBLY AT ANY PRESSURE UNLESS THE TOOL IS MOUNTED ON THE STUD.**

### WARNING

The safety cage MUST be in place and hands kept out of designated areas at all times when the tensioner is pressurized otherwise personal injury can occur.

### CAUTION

DO NOT EXCEED THE MAXIMUM PRESSURE VIBROSCRIBED ON THE PULLER BODY. Excessive pressure can damage the stud and the puller screw.

### WARNING

Fire Hazard! DO NOT heat when the puller assembly is in place. Personal injury or equipment damage may occur. Use of an Oxy-Acetylene torch is not recommended.

### NOTICE

Do not use more thread locking compound than specified or the nut may be VERY difficult to remove at disassembly.



215 Clinton Road.  
New Hartford, NY 13413  
Tel: 315-768-4855  
Fax: 315-768-4941  
Email: info@riverhawk.com

GE DRAWING NUMBER	REV.
373A4008	S
FIRST MADE FOR:	SH.

**Instruction Manual IM-101  
For Gas and Steam Turbine Tensioned Studs & Nuts**

**CAUTION**

DO NOT EXCEED THE MAXIMUM PRESSURE VIBROSCRIBED ON THE PULLER BODY. Excessive pressure can damage the stud and puller screw

**Note:** Before threading the puller screw into the stud, carefully check the cleanliness of both the stud's and the puller screw's conical threads. Apply a light coat of clean turbine oil or a spray lubricant to the puller screw. Do not use "Never Seize" on the conical threads. This procedure will ease assembly and assure positive mating of the threads before tightening.

**WARNING:**

Keep hands clear of the tool while the pressure is building up. This includes the pin wrench for tightening the spanner ring (nut). Once the tool is stabilized at pressure then and only then can the nut be tightened. This reduces the potential of personal injury should the puller screw have not been properly installed.

**2.0 Scope**

This document describes the procedure to be used to install the studs and nuts supplied by Riverhawk Company in the flanges at the turbine/coupling, coupling/gear, gear/generator, and steam turbine to generator connections. This hardware is depicted on the following drawings. These drawings as well as Tooling drawings form part of this manual.

HF-0131    HF-0222    HF-0579  
HF-0737    HF-0738    HF-0748  
HF-2140    HF-5204



215 Clinton Road.  
New Hartford, NY 13413  
Tel: 315-768-4855  
Fax: 315-768-4941  
Email: info@riverhawk.com

GE DRAWING NUMBER	REV.
373A4008	S
FIRST MADE FOR:	SH.

**Instruction Manual IM-101  
For Gas and Steam Turbine Tensioned Studs & Nuts**

**3.0 Quick Checklist**

The following checklist is intended as a summary of the steps needed to use the Riverhawk-supplied equipment. New personnel or those experienced personnel who have not used the Riverhawk equipment recently are encouraged to read the entire manual.

**EQUIPMENT INSPECTION**

- Check oil level in hydraulic pump.
- Check air pressure at 80 psi [5.5 bar] minimum. (For air-driven pumps)
- Check hydraulic hose for damage.
- Test pump.
- Inspect tensioner for any damage.

**NUT AND STUD PREPARATION**

- Inspect stud and nuts for any damage.
- Measure stud length.
- Clean the studs and nuts.
- Install studs and nuts (off-center) into the flange.
- Set stick-out dimension. Check hardware set drawing for stud direction.
- Hand tighten all studs.
- Verify stick-out measurement (VERY IMPORTANT)



215 Clinton Road.  
New Hartford, NY 13413  
Tel: 315-768-4855  
Fax: 315-768-4941  
Email: info@riverhawk.com

GE DRAWING NUMBER	REV.
373A4008	S
FIRST MADE FOR:	SH.

Tensioning (Bolt installation)

- Match the tensioner setup to the flange joint.
- Apply a light coat of clean turbine oil or spray lubricant to the puller screw. **DO NOT USE "NEVER SEIZE" ON THE CONICAL THREADS.**
- Slide spanner ring over the puller screw.
- Mount the tensioner on the stud in flange and install spanner ring onto nut.
- Insert 1/2" hex Allen wrench into the back side of the stud.
- Tighten the puller screw. Then back off puller screw 1/2 a turn.
- Retighten the puller screw and leave tight. **DO NOT BACK OFF PULLER SCREW.**
- Tighten puller nut and then back nut off two flats or 120 degrees to allow for stud stretch.
- Bleed the tensioner. **Do NOT bleed tensioner off of a stud! Damage to the tool will result!**
- Tension to 50%. Consult manual for correct pressure.
- Use the pin wrench in spanner ring to tighten nut.
- Release pressure, move to next stud in pattern.
- Repeat above steps at final pressure.
- Measure final stud length and record on stretch datasheets. Calculate stretch.
- Torque nuts' set screws.



215 Clinton Road.  
New Hartford, NY 13413  
Tel: 315-768-4855  
Fax: 315-768-4941  
Email: info@riverhawk.com

GE DRAWING NUMBER	REV.
373A4008	S
FIRST MADE FOR:	SH.

Detensioning (Stud removal)

- Loosen nuts' set screws
- Inspect and clean studs' conical threads. **Do not continue until ALL debris is removed from the threads! Do not try to use the tensioner to remove a damaged stud!**
- Apply a light coat of clean turbine oil or spray lubricant to the puller screw. **DO NOT USE "NEVER SEIZE" ON THE CONICAL THREADS.**
- Slide spanner ring over the puller screw.
- Mount the tensioner on the stud.
- Install spanner ring into nut.
- Tighten the puller screw. Then back off puller screw 1/2 a turn.
- Retighten the puller screw and leave tight. **DO NOT BACK OFF PULLER SCREW.**
- Tighten puller nut and then back nut off two flats or 120 degrees to allow for stud stretch.
- Bleed the tensioner. **Do NOT bleed tensioner off of a stud! Damage to the tool will result!**
- Apply final pressure.
- Loosen nut with the spanner ring and pin wrench.
- Move to next stud in pattern



215 Clinton Road.  
New Hartford, NY 13413  
Tel: 315-768-4855  
Fax: 315-768-4941  
Email: info@riverhawk.com

GE DRAWING NUMBER	REV.
373A4008	S
FIRST MADE FOR:	SH.

#### 4.0 General Preparations

**Read and understand all instructions before installing studs.**

This equipment produces very high hydraulic pressures and very high forces. Operators must exercise caution, wear safety glasses and hard hats when using this equipment.

High-pressure fluid from the Hydraulic Pressure Kit system pressurizes the tensioner which generates a stretching force that actually stretches the stud. As the stud is stretched the nut lifts off the flange. The nut is then reseated into position on the flange by turning a nut driver by hand. When the nut is tight against the flange, the pressure in the tensioner is released leaving the stud loaded to its predetermined value.

#### 4.1 Machine Preparation

The flange to be tensioned must be fully closed prior to positioning the studs in the flanges. There must be provisions for turning the shafts of the turbine, coupling, gearbox and generator. Also, it will be advantageous to remove as many obstructions as possible from the flange area, such as speed probes and conduit.

#### 4.2 Hardware - Balance

- Hardware is supplied as weight balanced sets
- Studs and Nuts are interchangeable within sets
- Do not mix with other sets
- Save weight certification data supplied with each set for the purchase of spares.



215 Clinton Road.  
New Hartford, NY 13413  
Tel: 315-768-4855  
Fax: 315-768-4941  
Email: info@riverhawk.com

GE DRAWING NUMBER	REV.
373A4008	S
FIRST MADE FOR:	SH.

Instruction Manual IM-101  
For Gas and Steam Turbine Tensioned Studs & Nuts

### 4.3 Tensioner - Care and Handling

- When not in use, the tensioner shall be maintained in a clean environment and all caps and plugs for hydraulic openings and fittings must be in place.
- When in use, the tensioner shall be protected from sand and grit
- Long term storage - coat tensioner with oil, return to original container, seal and protect from moisture.
- Shipment - coat tensioner with oil and ship in original container.

### 4.4 Hand Tools

Several hand wrenches and micrometers will be required to perform installation and measurement of the studs:

5/8" open-end wrench  
15/16" open-end  
1" wrench  
2-3/4" wrench  
3" wrench  
A set of Allen Wrenches  
3' - 4' Breaker Bar  
5" to 6" micrometer or caliper  
8" to 9" micrometer or caliper  
9" to 10" micrometer or caliper



215 Clinton Road.  
New Hartford, NY 13413  
Tel: 315-768-4855  
Fax: 315-768-4941  
Email: info@riverhawk.com

GE DRAWING NUMBER	REV.
373A4008	S
FIRST MADE FOR:	SH.

**Instruction Manual IM-101  
For Gas and Steam Turbine Tensioned Studs & Nuts**

**4.5 Special Tools**

Hydraulic Tensioner Kit:

HT-0406 Hydraulic Tensioner, 1-1/8"  
(recommended)  
(reference GE 364B3418)

HT-0141 Hydraulic Tensioner, 1-1/8"  
(for Kop-Flex couplings)

HT-0245 Hydraulic Tensioner, 1-1/8"  
(obsolete tool)

HT-0251 Hydraulic Tensioner, 1-1/8"  
(obsolete tool)

HT-0716 Hydraulic Tensioner, 2"  
(recommended)  
(reference GE 359B2503)

HT-3334 Hydraulic Tensioner, 2"  
(recommended)  
(reference GE 359B2584)

HT-0174 Hydraulic Tensioner, 2"  
(obsolete tool)

HT-0252 Hydraulic Tensioner, 2"  
(obsolete tool)

HT-0739 Hydraulic Tensioner, 2-3/4"

Hydraulic Pump Kit:

AP-0532 Air-operated Hydraulic  
Pump (recommended)  
(reference GE 359B2502)

MP-0130 Manual Hand-operated  
Hydraulic Pump  
(reference GE 359B2506)



215 Clinton Road.  
New Hartford, NY 13413  
Tel: 315-768-4855  
Fax: 315-768-4941  
Email: info@riverhawk.com

GE DRAWING NUMBER	REV.
373A4008	S
FIRST MADE FOR:	SH.

## 5.0 Hardware Set Preparations

### 5.1 Nut Preparation

For new installations the nuts should come sealed from the factory and will need no cleaning.

Previously installed nuts require cleaning as follows: Wire brush using a petroleum based solvent to remove any foreign material on the external surfaces and threads.

If previous installation employed a thread locking compound, which will be visible as a grayish-green residue, remove as much of this compound as possible.

**Do not apply thread lubricants to the threads.**

Finish the cleaning process by rinsing in a volatile solvent such as acetone and allow to dry.

### 5.2 Stud Preparation

For new installations, the studs should come sealed from the factory and will need no cleaning.

#### 5.2.1 Stud Cleaning - Old Installations

Previously installed studs may require cleaning. Clean conical threads should have a bright and shiny appearance.

If cleaning is required, follow these steps:

1. Blow out the threads with compressed air to remove loose debris and dry conical threads. Do not apply a solvent or other cleaning solution to the threads as this may chemically attack the stud.
2. Use Stud Cleaning Kit, GT-4354 or a similar 1/2" diameter Brass power brush.



Picture of Brass Power Brush



215 Clinton Road.  
New Hartford, NY 13413  
Tel: 315-768-4855  
Fax: 315-768-4941  
Email: info@riverhawk.com

GE DRAWING NUMBER	REV.
373A4008	S
FIRST MADE FOR:	SH.

**Instruction Manual IM-101  
For Gas and Steam Turbine Tensioned Studs & Nuts**

3. Insert the brush into an electric drill and set drill to run in a counterclockwise direction at high speed.
4. Work the drill in a circular motion while moving the brush in and out to clean all of the threads. Try not to hold the brush in one place too long, so as not to remove the stud's protective coating.
5. Blow out the threads with compressed air to remove loosened debris.
6. Visually inspect threads for cleanliness. Threads should be bright and shiny.
7. Repeat if any dirt can be seen in the threads.
8. Inspect threads for any damage that may have been caused by previous installation.

**Do not apply thread lubricants to the threads.**

Finish the cleaning process by rinsing in a volatile solvent such as acetone and allow to dry.

### **5.3 Stud Length Measurement**

Measure and record the initial length of the studs.

The following suggestions will improve your results:

- **Plan to start and finish any flange in the same day.**
- **Studs and flange must be at the same temperature**
- **Number each stud with a marker.**
- **Mark the location of the measurement on stud end with a permanent marker.**
- **Measure each stud to nearest 0.001 inch.**
- **Record each measurement on the supplied charts.**
- **Do not allow the measuring instruments to set in the sun**



215 Clinton Road.  
New Hartford, NY 13413  
Tel: 315-768-4855  
Fax: 315-768-4941  
Email: info@riverhawk.com

GE DRAWING NUMBER	REV.
373A4008	S
FIRST MADE FOR:	SH.

Instruction Manual IM-101  
For Gas and Steam Turbine Tensioned Studs & Nuts

## 6.0 Stud and Nut Assembly

Refer to the Hardware Assembly Drawing (HF-xxxx) listed in Section 2.0 of this manual.

1. Assemble the cylindrical nut to the tapered thread end (Pull End) of the stud.
2. Slide the stud and cylindrical nut assembly into the flange as shown in Figures 1, 2 & 3 and install the other nut on the backside.
3. Adjust nut/stud assembly so that the stud protrudes from the face of the cylindrical nut the amount depicted on the hardware drawing (HF-xxxx). **SETTING THIS PROTRUSION OF STUD TO NUT IS CRITICAL FOR PROPER TENSIONER OPERATION.**
4. Hand tighten the assembly to a snug fit.

## 7.0 Assembly of Hydraulic Tensioner Equipment

### 7.1 Kit Assembly

Assemble the hydraulic pump with its hose to the puller tool and bleed the system of air per following instructions.

Clean puller screw and check for any debris and dents.

Puller screw should be free to rotate and move back and forth.

Inspect tensioner guard for any signs of damage. Bent guards should be replaced.



215 Clinton Road.  
New Hartford, NY 13413  
Tel: 315-768-4855  
Fax: 315-768-4941  
Email: info@riverhawk.com

GE DRAWING NUMBER	REV.
373A4008	S
FIRST MADE FOR:	SH.

**Instruction Manual IM-101**  
**For Gas and Steam Turbine Tensioned Studs & Nuts**

**7.1.1 Hydraulic Fittings**

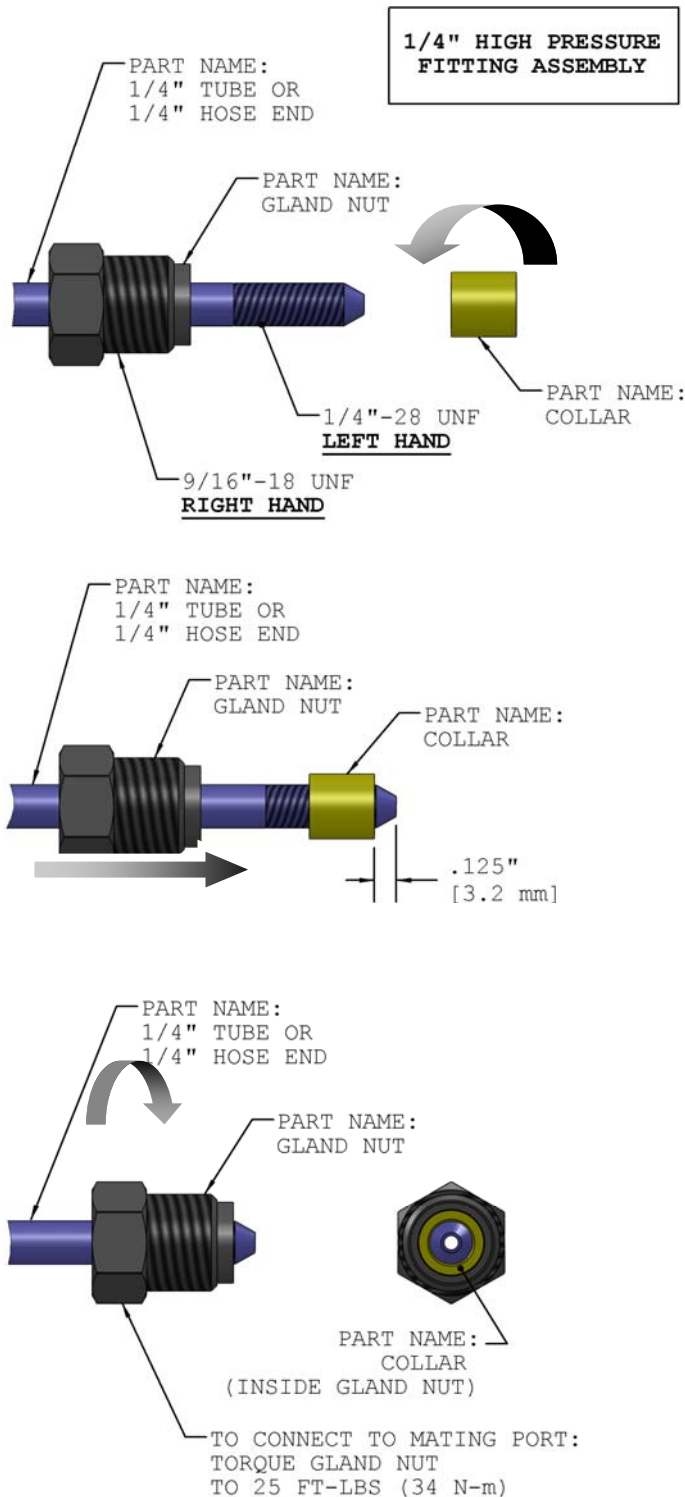

Riverhawk tensioners use a 1/4" High Pressure port to connect its hydraulic hoses. The hose connector is made from a three piece assembly: a gland nut, a collar, and a 1/4" tube or 1/4" hose end.

To assembly the fitting, slide the gland nut over the 1/4" tube or 1/4" hose end. Turn the collar counter-clockwise (**left hand** thread) on to the tube or hose end.

The collar should be placed .125" (3.2 mm) from the tip of the cone. It may be necessary to adjust this collar with a set of vise-grip pliers. Be careful to not strip the threads off the tube or hose end.

Slide the gland nut down over the collar. Insert the 1/4" tube or 1/4" hose end into tensioner or hydraulic pump. While firmly holding the tube or hose end to stop it from rotating, turn the gland nut clockwise (**right hand** thread) and torque the gland nut to 25 FT-LBS (34 N-m).

Tips:

- Make sure all parts are clean and free from debris.
- Protect the cone from scratches as this is the sealing surface.

Replace red plastic caps when finished to protect the threads and cone.



215 Clinton Road.  
 New Hartford, NY 13413  
 Tel: 315-768-4855  
 Fax: 315-768-4941  
 Email: info@riverhawk.com

GE DRAWING NUMBER	REV.
373A4008	S
FIRST MADE FOR:	SH.

Instruction Manual IM-101  
For Gas and Steam Turbine Tensioned Studs & Nuts

## 7.2 Check Hydraulic Pump Kit

The pump kit is shipped full of hydraulic oil. The pump reservoir cap is sealed for shipment.

Replace the grey shipping cap with the red plastic reservoir cap.

To use the pump, turn cap to the vent position and follow the operating instructions on the inside cover.

To prevent oil spillage, close cap when not in use. Lost oil should be replaced with Enerpac Hydraulic Oil. ISO 32 or equivalent hydraulic oil may be substituted.

Test pump by dead-heading (leave port plug in place) and run pump - should hold steady pressure.

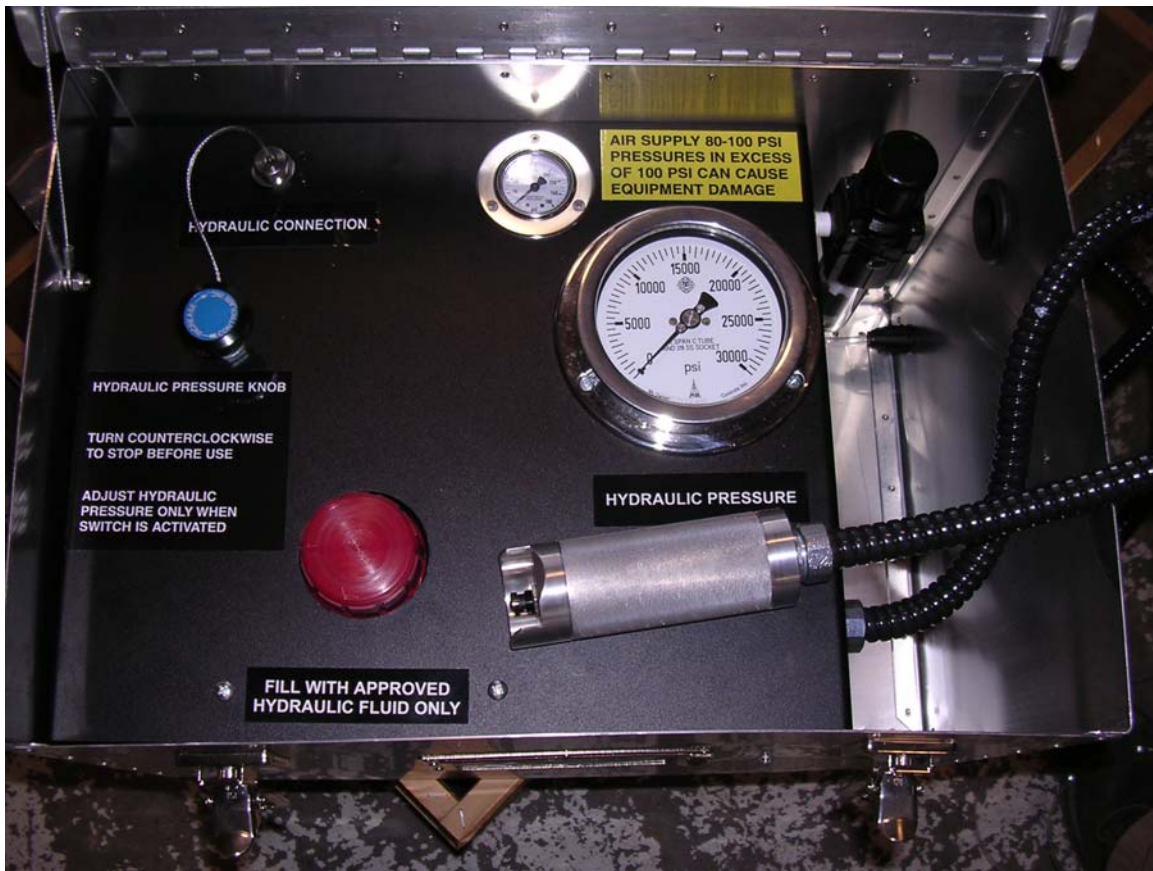

Sample Picture of AP-0532 Hydraulic Pump with hydraulic connection plugged for testing



215 Clinton Road.  
New Hartford, NY 13413  
Tel: 315-768-4855  
Fax: 315-768-4941  
Email: info@riverhawk.com

GE DRAWING NUMBER	REV.
373A4008	S
FIRST MADE FOR:	SH.

### 7.3 Bleeding Hydraulic System

Follow the tensioner assembly instructions of Section 8.0.

**TO AVOID FAILURE, ENSURE SAFETY AND PROPER OPERATION THE TENSIONER ASSEMBLY MUST BE MOUNTED ON THE STUD BEFORE BLEEDING THE SYSTEM AND TENSIONING BEGINS. DO NOT USE THE TENSIONER ASSEMBLY AT ANY PRESSURE UNLESS THE TOOL IS MOUNTED ON THE STUD.**

Mount tensioner on a stud per the assembly instructions of Section 8.0. Make sure the pump is situated below the tensioner assembly. The tensioner assembly has two ports, one for pressurizing and one for bleeding the system. These ports service a common chamber and therefore may be treated interchangeability. The bleed port must always be oriented in the uppermost position. The puller tool is shipped with a 5/8 in. [16 mm] hex coned stem bleeder fitting installed. With this fitting loosened stroke the pump repeatedly until the stream of oil exiting the tool is free of air then retighten the fitting.

**Note:** The hose is stiff, use of this tooling can be simplified by temporarily mounting the puller tool on one stud prior to final tightening of fittings. This will reduce the tendency for the fittings to loosen during use.

### 8.0 Assembly of Tensioner on Stud

Two types of Tensioner Kits will be encountered in the field. They are most readily identified by the safety cages that they employ. One cage is separate from the puller tool and the other is integral. Other design differences and operational characteristics are defined in Sections 8.1 and 8.2 that follow. The two assemblies are depicted in Figures 6 & 7.

All tensioning (pulling) will be performed from the tapered thread end of the stud with orientation of the stud to the flange as shown in Figures 1, 2, & 3.



215 Clinton Road.  
New Hartford, NY 13413  
Tel: 315-768-4855  
Fax: 315-768-4941  
Email: info@riverhawk.com

GE DRAWING NUMBER	REV.
373A4008	S
FIRST MADE FOR:	SH.

### 8.1 Assembly of Tensioner Kit with Separate Safety Cage

Refer to Tensioner Assembly drawing and Figure 6 for tensioner to flange mounting. Assembly sequence is as follows:

1. Open the hydraulic return valve on the pump to allow hydraulic fluid to be pushed back from the puller tool into the pump reservoir as the puller tool is tightened. (This is automatic on the air-operated hydraulic pump)
2. Place the spanner ring on the puller side nut.
3. Apply a light coat of clean turbine oil or a spray lubricant to the puller screw. Do not use "Never Seize" on the conical threads
4. Place and hold the puller tool over the end to be tightened.
5. Insert the puller screw through the puller tool into the tapered thread of the stud and hand tighten
6. Be sure not to cross-thread the assembly
7. Tighten the puller screw using an open-end wrench and spanner or Allen wrench, depending on hardware configuration, on the opposite end of the stud (DO NOT WRENCH THE NUT).
8. At this point the Tensioner Assembly **MUST BE FREE TO ROTATE**, the puller screw is tight in the stud and the puller nut has been backed-off the 2 flats.

**Note:** If the tool is not free to rotate when the puller screw is tight, then either: (1) The piston is not fully retracted; open the valve on the pump and retighten the puller screw. Or (2) the nuts must be repositioned so that the stud is shifted slightly more on the puller tool side. This can be done as follows:

1. Slightly loosen the puller screw.
2. Back the nut opposite puller tool off 1/2 turn.
3. Tighten the puller screw side nut to take up the slack.
4. Retighten the puller screw per above and check for looseness of tool.



215 Clinton Road.  
New Hartford, NY 13413  
Tel: 315-768-4855  
Fax: 315-768-4941  
Email: info@riverhawk.com

GE DRAWING NUMBER	REV.
373A4008	S
FIRST MADE FOR:	SH.

## 8.2 Assembly of Tensioner Kit with Integral Safety Cage

Refer to Tensioner Assembly drawing and Figure 7 for tensioner to flange mounting. This assembly has the following features that should make stud tensioning safer and easier.

- The safety cage is integral (bolted) to the puller tool
- The hydraulic piston is spring loaded to retract
- The puller screw is a 2-piece design, This requires that the operator tighten the puller screw into the stud and then install a puller nut.

Assembly sequence is as follows:

1. Open the hydraulic return valve on the pump to allow hydraulic fluid to be pushed back from the puller tool into the pump reservoir. (This is automatic on the air-operated hydraulic pump)
2. Place the spanner ring on the puller side cylindrical nut.
3. Apply a light coat of clean turbine oil or a spray lubricant to the puller screw. Do not use "Never Seize" on the conical threads
4. Place and hold the puller tool over the end to be tightened.
5. Insert the puller screw through the puller tool into the tapered thread of the stud and hand tighten.
- 6. Be sure not to cross-thread the assembly.**
7. Tighten the puller screw using Allen wrenches on the puller screw and the stud. DO NOT wrench on the Hex nut opposite the puller tool.
8. Install the puller nut until it seats snugly on the piston and then back-off 2 flats. This is particularly important for removal because the stud shortens during disassembly and the tensioner may then bind.
9. At this point the Tensioner Assembly **MUST BE FREE TO ROTATE.** the puller screw is tight in the stud and the puller nut has been backed-off the 2 flats.



215 Clinton Road.  
New Hartford, NY 13413  
Tel: 315-768-4855  
Fax: 315-768-4941  
Email: info@riverhawk.com

GE DRAWING NUMBER	REV.
373A4008	S
FIRST MADE FOR:	SH.

**Instruction Manual IM-101  
For Gas and Steam Turbine Tensioned Studs & Nuts**

**Note:** If the tool is not free to rotate it is most likely that the nuts must be repositioned so that the stud may be shifted slightly to the puller tool side of the flange. This can be accomplished as follows:

1. Back-off the puller nut and slightly loosen the puller screw.
2. Back-off the Hex nut opposite the puller tool 1 /2 turn.
3. Tighten the puller screw side cylindrical nut to take up the slack
4. Retighten the puller screw per above and check for tool looseness

**Note:** Do not over extend the stud. Over extension can cause the piston to lose it's seal and leak oil.

**CAUTION**

**Personal injury and equipment damage can occur if the puller screw is not securely engaged with the tapered threads of the stud. Proper engagement is achieved when the puller screw is tight in the stud and the tensioner assembly is free to turn.**

### **9.0 Stud Pulling and Tensioning**

The studs will be tensioned in two steps, at approximately 50% pressure and at final pressure. Follow the tensioning sequence for each flange joint as defined on the data sheets found at the end of this manual.

**Note:** Before threading the puller screw into the stud, carefully check the cleanliness of both the stud's and the puller screw's conical threads. Apply a light coat of clean turbine oil or a spray lubricant to the puller screw. Do not use "Never Seize" on the conical threads. This procedure will ease assembly and assure positive mating of the threads before tightening.

**WARNING**

**The safety cage MUST be in place and hands kept out of designated areas at all times when the puller tool is pressurized otherwise personal injury can occur.**



215 Clinton Road.  
New Hartford, NY 13413  
Tel: 315-768-4855  
Fax: 315-768-4941  
Email: info@riverhawk.com

GE DRAWING NUMBER	REV.
373A4008	S
FIRST MADE FOR:	SH.

**Instruction Manual IM-101  
For Gas and Steam Turbine Tensioned Studs & Nuts**

**9.1 Tensioning at 50% pressure**

After the tensioner is properly installed apply hydraulic pressure to the tool. Bring the pressure to the 50% level in accordance with the following table.

<u>Flange Position</u>	<u>Stud Size</u>	<u>50% Pressure</u>	<u>50% Stretch</u>
Turbine to Coupling	1-1/8" [29 mm]	9000 psi [620 bar]	Do not measure Do not use
Coupling to Gearbox	1-1/8" [29 mm]	9000 psi [620 bar]	Do not measure Do not use
Gearbox to Generator	2" [51 mm]	8000 psi [550 bar]	Do not measure Do not use
Steam Turbine to Generator	2" [51 mm]	8000 psi [550 bar]	Do not measure Do not use
Gearbox to Generator	2-3/4" [71 mm]	9000 psi [620 bar]	Do not measure Do not use
Steam Turbine to Generator	2-3/4" [71 mm]	9000 psi [620 bar]	Do not measure Do not use

**9.1.1 Tightening of 1 1/8" Nuts**

Tighten the cylindrical nuts hand tight using the pin wrench and spanner ring, ref. Figure 6 & 7 Turn nut until it bottoms on flange. Then apply torque to turn nut an additional 10 degrees. Torquing nut will aid in achieving the desired stretch.

**9.1.2 Tightening of 2" Nuts**

Tighten the cylindrical nuts hand tight using the pin wrench and the spanner ring, ref, Figure 6 & 7. No torque is required once the nut is seated. Torquing will result in added stretch.

**9.1.3 Tightening of 2 3/4" Nuts**

Tighten the cylindrical nuts hand tight using the pin wrench and spanner ring ref. Figure 6 & 7.



215 Clinton Road.  
New Hartford, NY 13413  
Tel: 315-768-4855  
Fax: 315-768-4941  
Email: info@riverhawk.com

GE DRAWING NUMBER	REV.
373A4008	S
FIRST MADE FOR:	SH.

### 9.2 Removing the Tensioner from an Installed Stud

Puller tool removal is to be accomplished as follows:

1. Release the puller tool pressure by opening the valve on the pump. Leave valve open. (This is automatic on the air-operated hydraulic pump)
2. Unscrew the puller screw using a wrench.
3. Tapping the wrench with a hammer may be necessary to loosen the puller screw
4. Move the tool to the next stud/nut assembly to be tensioned, following the sequence/pattern as defined on the supplied data sheets

### 9.3 Tensioning at Final Pressure

Repeat the pulling and tightening procedure stated above at full pressure. Measure the length of the studs after all have been tensioned. The final pressure and required stretch values are listed in the following table

<u>Flange Position</u>	<u>Stud Size</u>	<u>Final Pressure</u>	<u>Final Stretch</u>
Turbine to Coupling	1-1/8" [29 mm]	18000 psi [1240 bar]	0.010" - 0.012" [0.25 mm - 0.31 mm]
Coupling to Gearbox	1-1/8" [29 mm]	18000 psi [1240 bar]	0.010" - 0.012" [0.25 mm - 0.31 mm]
Gearbox to Generator	2" [51 mm]	16000 psi [1100 bar]	0.010" - 0.012" [0.25 mm - 0.31 mm]
Steam Turbine to Generator	2" [51 mm]	16000 psi [1100 bar]	0.010" - 0.012" [0.25 mm - 0.31 mm]
Gearbox to Generator	2-3/4" [71 mm]	17500 psi [1200 bar]	0.009" - 0.011" [0.23 mm - 0.28 mm]
Steam Turbine to Generator	2-3/4" [71 mm]	17500 psi [1200 bar]	0.009" - 0.011" [0.23 mm - 0.28 mm]

#### CAUTION

**DO NOT EXCEED THE MAXIMUM PRESSURE VIBROSCRIBED ON THE PULLER BODY. Excessive pressure can damage the stud and the puller screw.**



215 Clinton Road.  
New Hartford, NY 13413  
Tel: 315-768-4855  
Fax: 315-768-4941  
Email: info@riverhawk.com

GE DRAWING NUMBER	REV.
373A4008	S
FIRST MADE FOR:	SH.

## **10.0 Retensioning**

Excessive stretch variations or low stretch values can be corrected by retensioning all or selected studs to the pressure values stated in the above table. Have final stretch values approved by the supervisor responsible for the installation.

## **11.0 Thread Locking**

Once pulling and tensioning is completed all stud nuts must be locked in position. Two methods of thread locking may be encountered in the field. Early version hardware entails a liquid thread- locking compound while the later configuration employs a mechanical locking device. Each method is described in detail in Sections 11.1 & 11.2.

### **11.1 Thread Locking Using a Liquid Locking Compound**

These nuts have no visible locking feature.

Apply the specified number of drops (see table below) of thread locking compound Permatex Industrial "After Lock" No. 81794 (included with each set of hardware from the factory) to each end of the stud at the stud/nut interface as follows.

Apply the drops to the face of the nut at the top of the assembly allowing material to run down onto the stud threads.

An alternate method of applying the thread locking compound is to use a short (2-3") length of thin wire. Place the bottom tip of the wire at the top of the nut/stud thread interface with the wire held at about a 45 deg. angle. Apply the liquid to the wire so that it runs along the wire into the threads.

<u>Stud Size</u>	<u>Amount of Liquid</u>
1-1/8" [29 mm]	4 drops
2" [51 mm]	6 drops
2-3/4" [71 mm]	7 drops

### **NOTICE**

**Do not use more thread locking compound than recommended or the nut may be VERY difficult to remove at disassembly.**



215 Clinton Road.  
New Hartford, NY 13413  
Tel: 315-768-4855  
Fax: 315-768-4941  
Email: info@riverhawk.com

GE DRAWING NUMBER	REV.
373A4008	S
FIRST MADE FOR:	SH.

## 11.2 Thread Locking Using a Mechanical Locking Device

Mechanical lock nuts have two set screws located in the top face, see Figure 6. Before threading the nut onto the stud check to be certain the set screws are free to turn. Once the nut is seated torque the set screws to the values specified in the following table. When seated and torqued to the values specified the load created by the set screw displaces the thread of the nut in the area of the web creating the desired locking action.

<u>Stud Size</u>	<u>Set Screw Size</u>	<u>Torque</u>
1-1/8" [29 mm]	#10-32 UN	30 in·lbs - 36 in·lbs [3.4 N·m - 4.1 N·m]
2" [51 mm]	1/4"-28 UN	65 in·lbs - 87 in·lbs [7.3 N·m - 9.8 N·m]
2-3/4" [71 mm]	3/8"-24 UN	200 in·lbs - 250 in·lbs [22.6 N·m - 28.2 N·m]

## 12.0 Stud/Nut removal

Sections 12.1 and 12.2 respectively describe the procedures to be followed in removing nuts that have been locked with liquid locking compound and those with the mechanical locking feature.



215 Clinton Road.  
New Hartford, NY 13413  
Tel: 315-768-4855  
Fax: 315-768-4941  
Email: info@riverhawk.com

GE DRAWING NUMBER	REV.
373A4008	S
FIRST MADE FOR:	SH.

### 12.1 Removal of Assemblies with Liquid Locking Compound

For those assemblies which have been locked with the liquid locking compound, removal is accomplished as follows:

1. Using a wire brush and shop air clean the internal tapered thread of the stud to remove any debris/deposits that may have accumulated during service. (see section 5.2.1)
2. Install the appropriate puller tool to the stud as described in Section. 8.0.
3. Apply hydraulic pressure per the following table and without using unreasonable force attempt to loosen the nut using the spanner ring and spanner wrench as shown in Figure 5

Stud Size	Puller Pressure
1-1/8" [29 mm]	18,000 psi [1240 bar]
2" [51 mm]	16,000 psi [1100 bar]
	18,000 psi [1240 bar] on units installed before manual Rev M
2-3/4" 71 mm]	17,500 psi [1200 bar]

If the nut cannot be loosened, release the pressure and repeat the procedure. Ordinarily two or three attempts are sufficient to break the bond. Should the nut refuse to loosen after three attempts the application of heat will be required.

**CAUTION**

**DO NOT EXCEED THE MAXIMUM PRESSURE VIBROSCRIBED ON THE PULLER BODY. Excessive pressure can damage the stud and the puller screw.**

**WARNING:**

**Fire Hazard, DO NOT heat when puller assembly is in place. Personal injury or equipment damage may occur. Use of an Oxy-Acetylene torch is not recommended**

Apply a smear of 550/650 deg F tempil stick to the side of the nut opposite the application of heat and heat the nut using a propane torch. Continue to apply heat until the tempil smear indicates that the nut has reached 550/650 deg F. **Never overheat to a cherry red condition.** Remove the source of heat and as quickly as possible reinstall the appropriate puller tool, apply the appropriate pressure and loosen the nut. Then release the pressure and remove the puller tool.



215 Clinton Road.  
New Hartford, NY 13413  
Tel: 315-768-4855  
Fax: 315-768-4941  
Email: info@riverhawk.com

GE DRAWING NUMBER	REV.
373A4008	S
FIRST MADE FOR:	SH.

## 12.2 Removal of Assemblies with Mechanical Locknuts

For those assemblies which have been locked using mechanical lock nuts, removal is accomplished as follows:

1. Using a wire brush and shop air clean the internal tapered thread of the stud to remove any debris/deposits which may have accumulated during service. (see section 5.2.1)
2. With an Allen-wrench loosen the two locking set screws but do not remove from nut see Figure 5.
3. Install the appropriate puller tool to the stud as described in Section 8.0.
4. Apply the appropriate hydraulic pressure per the table of Section 9.3 and using the spanner ring and spanner wrench as shown in Figure 6 loosen the nut, then release the pressure and remove the puller tool.

## 13.0 Frequently Asked Questions

This section contains some frequently asked questions and problems. If the steps listed here do not solve your problem, contact the Riverhawk Company thru our website, email, or phone call.

- Q:** A tensioner has pulled itself out of the stud's conical threads. Can I continue using a tensioner on this stud?
- A:** No. Both the tensioner and the stud may have been damaged. If the stud is tensioned, a Nut Buster repair kit, from Riverhawk, must be used to remove the damaged stud by drilling out the nut. Riverhawk can supply a replacement stud and nut based on the initial weight certification supplied with the hardware set (see section 4.2). The damaged tensioner should also be returned to Riverhawk for inspection and repair.



215 Clinton Road.  
New Hartford, NY 13413  
Tel: 315-768-4855  
Fax: 315-768-4941  
Email: info@riverhawk.com

GE DRAWING NUMBER	REV.
373A4008	S
FIRST MADE FOR:	SH.

**Instruction Manual IM-101  
For Gas and Steam Turbine Tensioned Studs & Nuts**

- Q:** The hydraulic tensioner has been taken up to its final pressure. The final stretch length is short of the final stretch target. What is the next step?
- A:** Do not increase the hydraulic pressure. Check if the hydraulic pump is set to the right pressure. Install the tensioner and re-pressurize the tensioner to the final pressure then recheck the stretch measurement. If the stretch value is still short, remove the stud from the hole and re-measure the stud's initial length then try to install the stud again.
- Q:** The hydraulic tensioner has been taken up to its final pressure. The final stretch length is larger than the final stretch target. What is the next step?
- A:** Remove the stud from the bolt hole. Check if the hydraulic pump is set to the right pressure. Re-measure the stud's initial length then try to install the stud again.
- Q:** Is there an easier way to support or move the tensioner around the coupling shaft?
- A:** Use two straps. One around the coupling shaft and the other attach to any overhead support. Straps must be slack during mounting tensioner to stud and during tensioning.
- Q:** The tensioner is at its final pressure, but the nut cannot be loosen.
- A:** If the nuts cannot be loosened at the final pressure, continually increasing the pressure will not help and can be dangerous and in some cases make it harder to remove the nut. Check the nut to see if its set screws have been loosened. Check for and remove any corrosion around the nut's threads.
- Q:** How do I clean the conical threads on a stud?
- A:** The conical threads are best cleaned using a spiral wound brass brush in a drill as described in section 5.2.1



215 Clinton Road.  
New Hartford, NY 13413  
Tel: 315-768-4855  
Fax: 315-768-4941  
Email: info@riverhawk.com

GE DRAWING NUMBER	REV.
373A4008	S
FIRST MADE FOR:	SH.

**Instruction Manual IM-101  
For Gas and Steam Turbine Tensioned Studs & Nuts**

**Q:** During the initial steps of removing a tensioned stud, the stick-out length is found to be wrong.

**A:** Do not proceed. Contact Riverhawk for assistance. With the wrong stick-out length, the hydraulic tensioner has a limited stroke and may not work properly and can be damaged.

**Q:** The hydraulic pump appears to be leaking.

**A:** Check the hose connection to the hydraulic pump. If the 1/4" high pressure fitting is not assembled correctly, it may look like the pump is leaking. If the problem continues, it may be necessary to open the pump kit. Contact Riverhawk for guidance.

**Q:** The hydraulic hose has a collar on it that can't be moved by hand

**A:** The collar is sometimes held in place with a thread locking compound. This prevents the collar from moving too easily. It may be necessary to adjust this collar with a set of vise-grip pliers. Be careful to not strip the threads off the tube or hose end.



215 Clinton Road.  
New Hartford, NY 13413  
Tel: 315-768-4855  
Fax: 315-768-4941  
Email: info@riverhawk.com

GE DRAWING NUMBER	REV.
373A4008	S
FIRST MADE FOR:	SH.

**Instruction Manual IM-101  
For Gas and Steam Turbine Tensioned Studs & Nuts**

**14.0 Revision History**

Revision Letter	Effective Date	Description
S	Sep 14, 2011	Revised sections 7.1.1 and 7.2, Revised figure 3, Removed figure 4.
R	Jun 16, 2011	Added Steam Turbine to 6FA Generator to title page, Added HF-0748 to section 2.0, Added HT-3334 to section 4.5, Added Steam Turbine to Generator 2" section to tables in sections 9.1 and 9.3, Revised Figure 3
Q	Jan 31, 2011	Added Steam Turbine to 9A4 Elin Generator to title page, Added Steam turbine to generator 2-3/4" section to tables in sections 9.1 and 9.3
P	Jun 10, 2009	Added turbine oil and removed "Never Seize" from sections 1.0, 3.0, 8.1, 8.2, and 9.0
N	Mar 25, 2009	Added sections 3.0 and 13.0
M	Jul 18, 2006	Revised generator stretch value
L		
K	Dec 10, 2004	Moved caution notes
J	Jun 15, 2004	Corrected stretch value error
H	Dec 08, 2003	Added GE title block and part number
G	Sept 22, 2003	Revised record sheet to reflect 27 studs
F	Jun 19, 2000	Page 2 para 2.0, Page 4 para 4.0 & 5.3, Page 8 para 7.2, Page 9 para 9.1
E	Jan 10, 2000	Page 1
D	Jul 20, 1999	



215 Clinton Road.  
New Hartford, NY 13413  
Tel: 315-768-4855  
Fax: 315-768-4941  
Email: info@riverhawk.com

GE DRAWING NUMBER	REV.
373A4008	S
FIRST MADE FOR:	SH.

**Instruction Manual IM-101  
For Gas and Steam Turbine Tensioned Studs & Nuts**

Revision Letter	Effective Date	Description
C	Apr 01, 1999	
B	May 09, 1997	
A	Feb 12, 1997	
-	Sept 03, 1996	Released



215 Clinton Road.  
New Hartford, NY 13413  
Tel: 315-768-4855  
Fax: 315-768-4941  
Email: info@riverhawk.com

GE DRAWING NUMBER	REV.
373A4008	S
FIRST MADE FOR:	SH.

**Instruction Manual IM-101  
For Gas and Steam Turbine Tensioned Studs & Nuts**

FIGURE 1

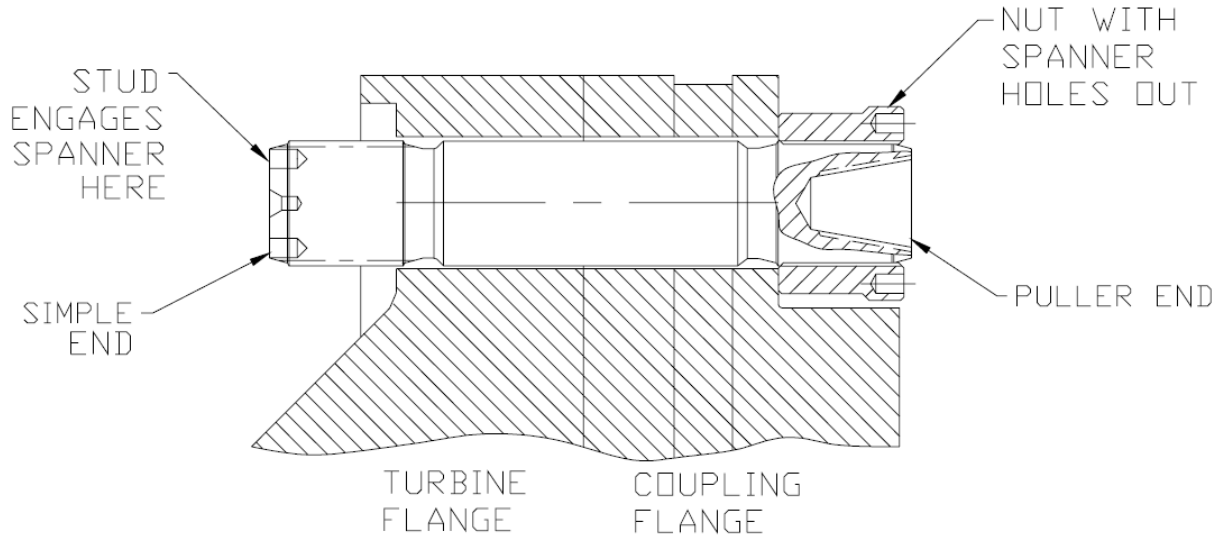
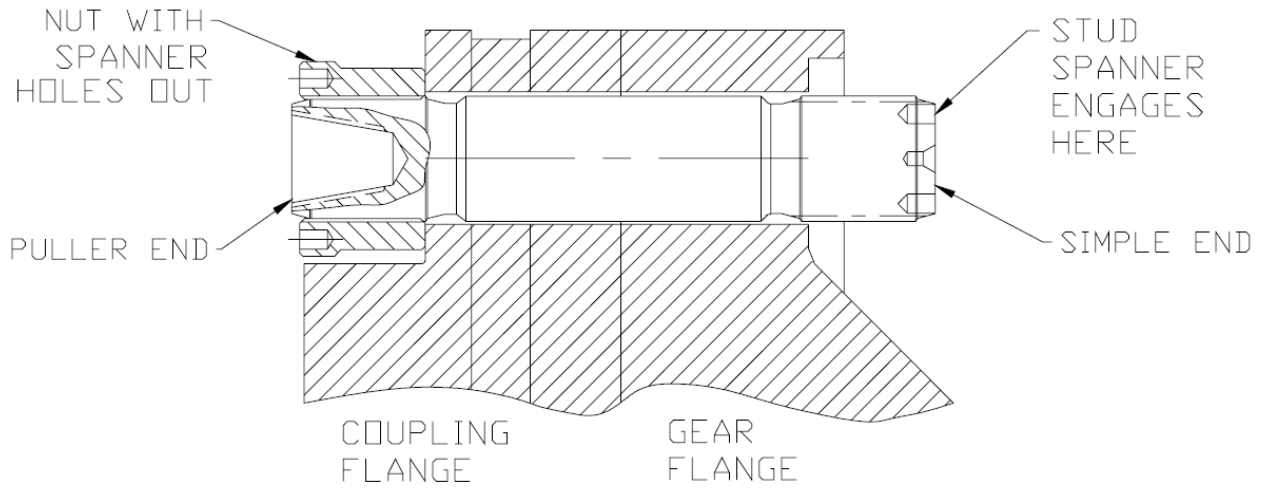

FIGURE 2



215 Clinton Road.  
New Hartford, NY 13413  
Tel: 315-768-4855  
Fax: 315-768-4941  
Email: info@riverhawk.com

GE DRAWING NUMBER	REV.
373A4008	S
FIRST MADE FOR:	SH.

**Instruction Manual IM-101  
For Gas and Steam Turbine Tensioned Studs & Nuts**

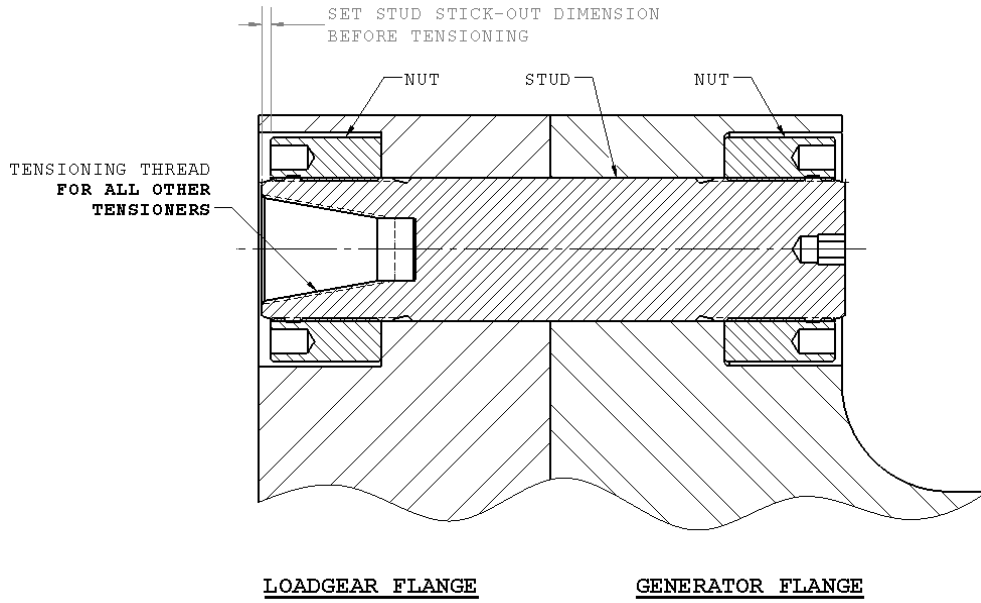

Figure 3A

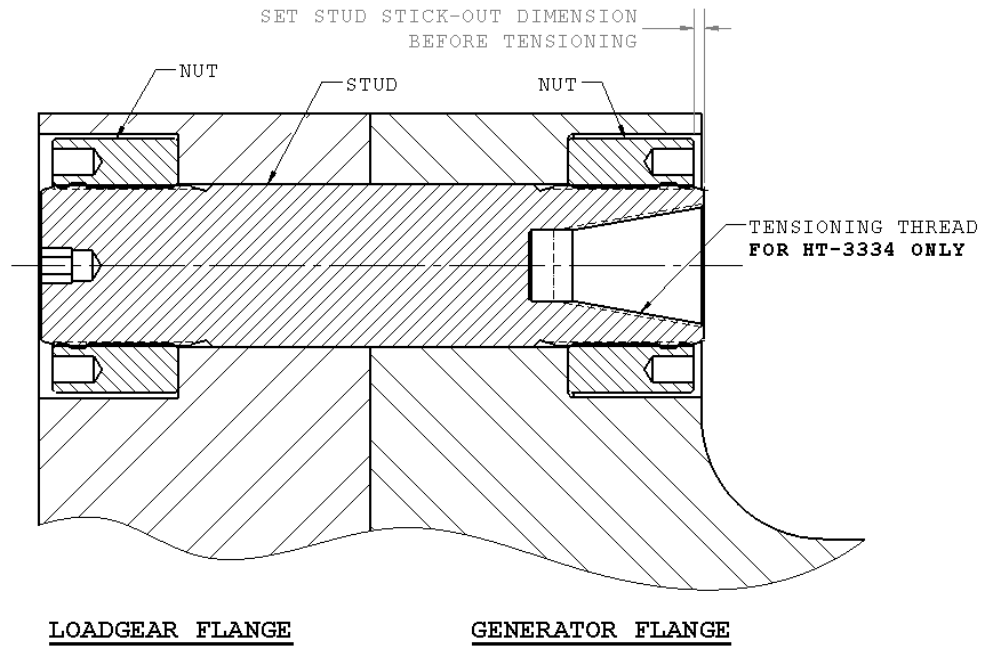

Figure 3B

Figure 4 has been removed.



215 Clinton Road.  
New Hartford, NY 13413  
Tel: 315-768-4855  
Fax: 315-768-4941  
Email: info@riverhawk.com

GE DRAWING NUMBER	REV.
373A4008	S
FIRST MADE FOR:	SH.

**Instruction Manual IM-101  
For Gas and Steam Turbine Tensioned Studs & Nuts**

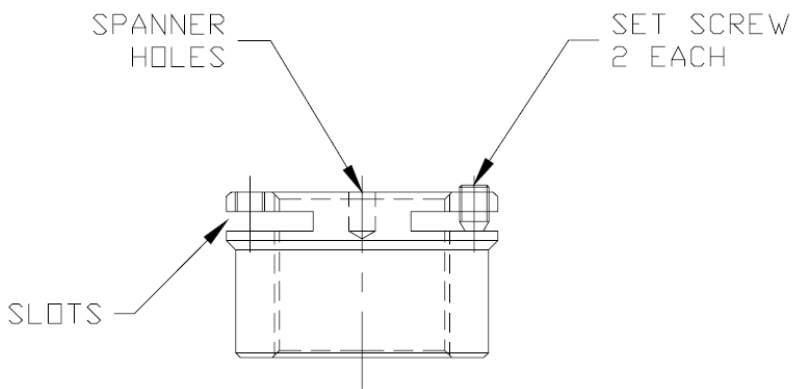
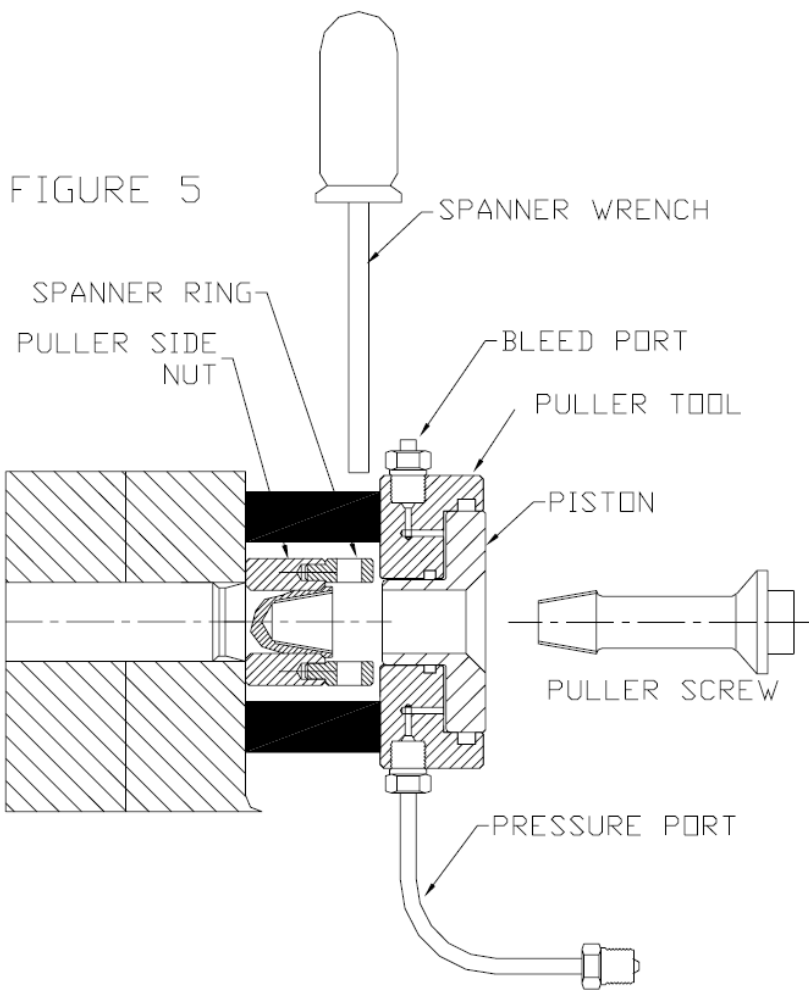

TYPICAL STUD LOCKNUT  
FIGURE 6



215 Clinton Road.  
New Hartford, NY 13413  
Tel: 315-768-4855  
Fax: 315-768-4941  
Email: info@riverhawk.com

GE DRAWING NUMBER	REV.
373A4008	S
FIRST MADE FOR:	SH.

**Instruction Manual IM-101  
For Gas and Steam Turbine Tensioned Studs & Nuts**

FIGURE 7  
INTEGRAL GUARD  
TENSIONER MOUNTED ON  
TURBINE FLANGE.

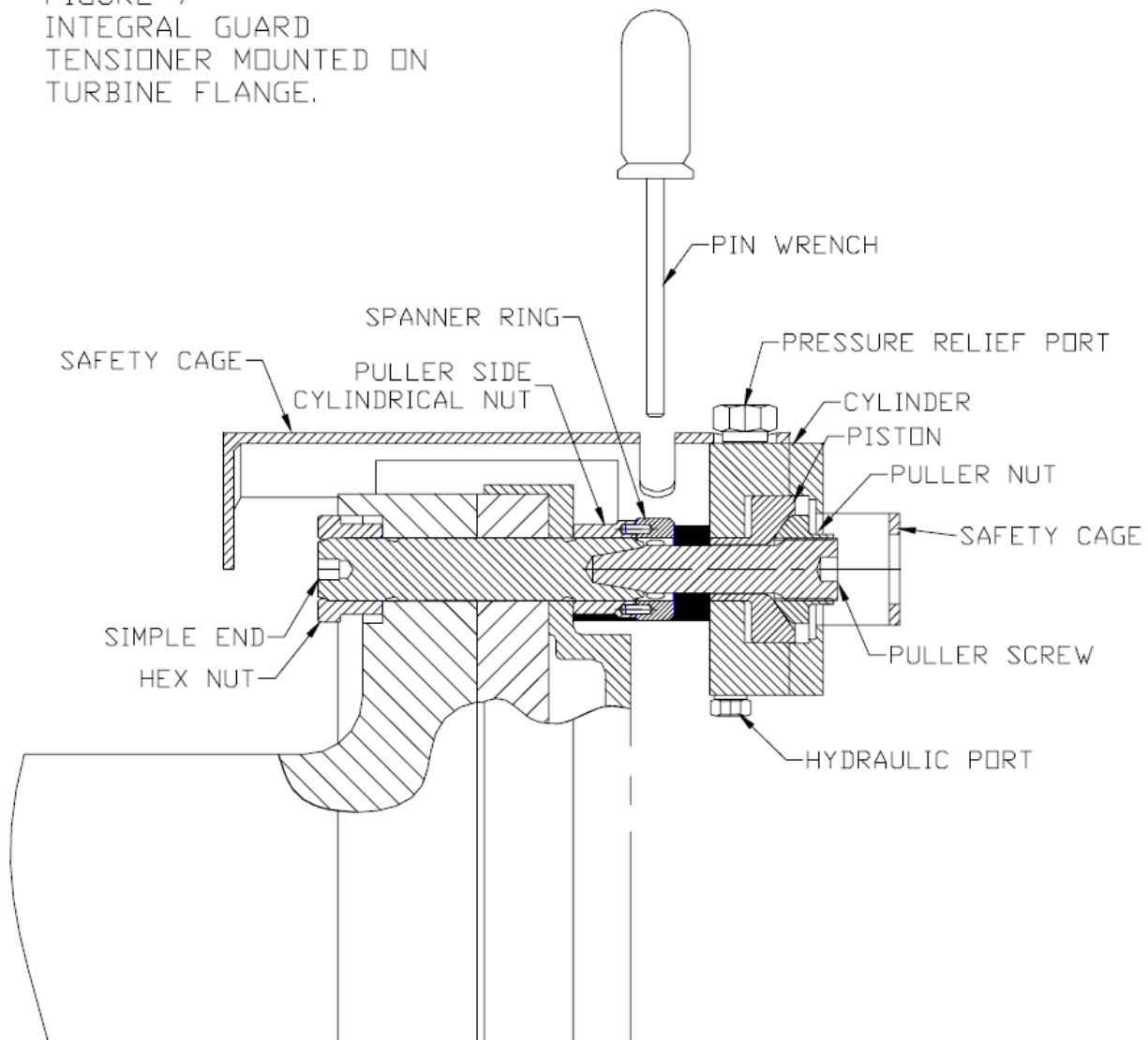

215 Clinton Road.  
New Hartford, NY 13413  
Tel: 315-768-4855  
Fax: 315-768-4941  
Email: info@riverhawk.com

GE DRAWING NUMBER	REV.
373A4008	S
FIRST MADE FOR:	SH.

Instruction Manual IM-101  
For Gas and Steam Turbine Tensioned Studs & Nuts

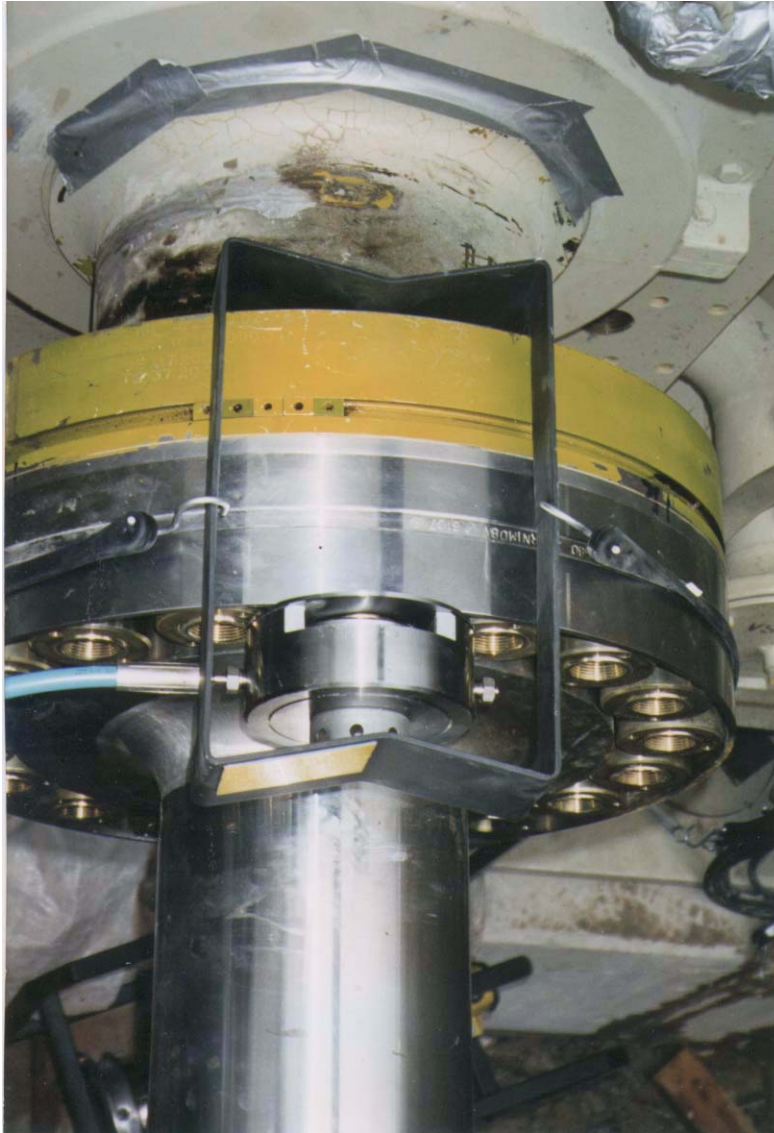

Photo 1  
Looking down on gear to generator  
flange of 6FA machine. Shows 2" puller  
tool mounted with safety cage in place.



215 Clinton Road.  
New Hartford, NY 13413  
Tel: 315-768-4855  
Fax: 315-768-4941  
Email: info@riverhawk.com

GE DRAWING NUMBER	REV.
373A4008	S
FIRST MADE FOR:	SH.

Instruction Manual IM-101  
For Gas and Steam Turbine Tensioned Studs & Nuts

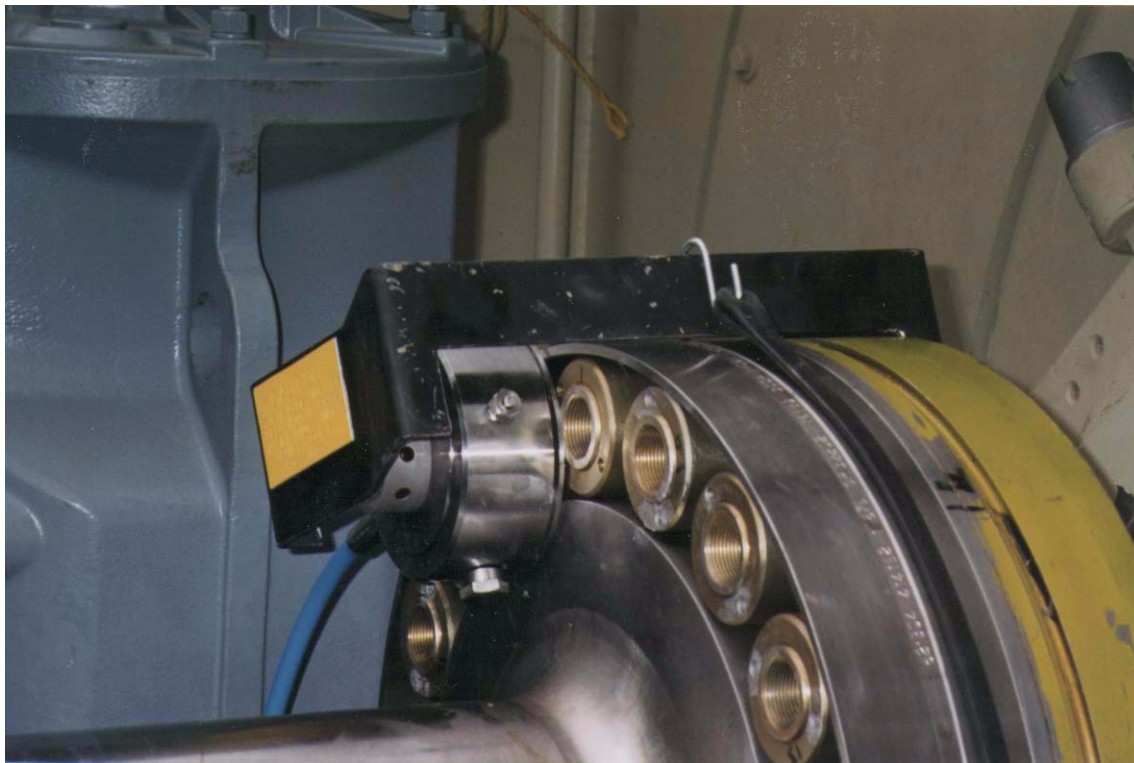

Photo 2  
Side view of 2" puller  
tool and safety cage on  
6FA machine.



215 Clinton Road.  
New Hartford, NY 13413  
Tel: 315-768-4855  
Fax: 315-768-4941  
Email: info@riverhawk.com

GE DRAWING NUMBER	REV.
373A4008	S
FIRST MADE FOR:	SH.

Instruction Manual IM-101  
For Gas and Steam Turbine Tensioned Studs & Nuts



Photo 3  
Top view of 1-1/8" puller tool and  
safety cage in place. Tool is  
mounted on coupling to gear flange  
of 6FA machine.



215 Clinton Road.  
New Hartford, NY 13413  
Tel: 315-768-4855  
Fax: 315-768-4941  
Email: info@riverhawk.com

GE DRAWING NUMBER	REV.
373A4008	S
FIRST MADE FOR:	SH.

Instruction Manual IM-101  
For Gas and Steam Turbine Tensioned Studs & Nuts



Photo 4  
View of 1-1/8" puller tool and safety cage mounted on turbine to coupling flange of 6FA machine. Tool is pressurized and millwright is tightening nut.



215 Clinton Road.  
New Hartford, NY 13413  
Tel: 315-768-4855  
Fax: 315-768-4941  
Email: info@riverhawk.com

GE DRAWING NUMBER	REV.
373A4008	S
FIRST MADE FOR:	SH.

**Instruction Manual IM-101  
For Gas and Steam Turbine Tensioned Studs & Nuts**

	REVISIONS	DATE	APPROVED
1			
2			
3			
4			

**STRETCH RECORD SHEET FOR (16) STUD PATTERN**

STUD LOCATION	ORIGINAL LENGTH	FIRST PULL		SECOND PULL	
		LENGTH (1)	STRETCH (1)	LENGTH (2)	STRETCH(2)
1	---	---	---	---	---
2	---	---	---	---	---
3	---	---	---	---	---
4	---	---	---	---	---
5	---	---	---	---	---
6	---	---	---	---	---
7	---	---	---	---	---
8	---	---	---	---	---
9	---	---	---	---	---
10	---	---	---	---	---
11	---	---	---	---	---
12	---	---	---	---	---
13	---	---	---	---	---
14	---	---	---	---	---
15	---	---	---	---	---
16	---	---	---	---	---

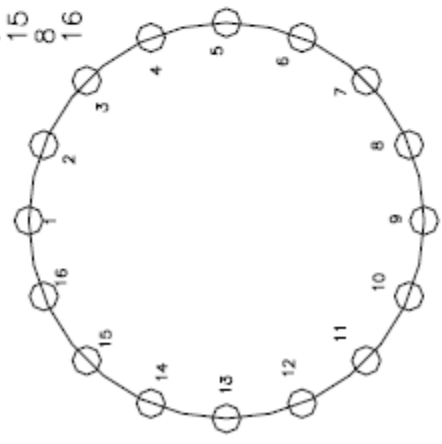

STATE UNITS: INCHES OR MILLIMETERS

AVG. STRETCH \_\_\_\_\_

AVG. STRETCH \_\_\_\_\_

FINAL \_\_\_\_\_

MACHINE \_\_\_\_\_

FLANGE \_\_\_\_\_

DATE \_\_\_\_\_

TECHNICIAN \_\_\_\_\_

SUPERVISOR \_\_\_\_\_

**TIGHTENING PATTERN FOR (16) STUDS**

970308-001

THE INFORMATION CONTAINED IN THIS DOCUMENT IS PROPRIETARY TO RIVERHAWK COMPANY AND MAY NOT BE COPIED, USED FOR MANUFACTURE, USED FOR DESIGN OF OTHER COMPONENTS OR RELEASED TO ANY OTHER PARTY WITHOUT EXPRESS WRITTEN PERMISSION FROM RIVERHAWK COMPANY.



215 Clinton Road.  
New Hartford, NY 13413  
Tel: 315-768-4855  
Fax: 315-768-4941  
Email: info@riverhawk.com

GE DRAWING NUMBER	REV.
373A4008	S
FIRST MADE FOR:	SH.

Instruction Manual IM-101  
 For Gas and Steam Turbine Tensioned Studs & Nuts

**STRETCH RECORD SHEET FOR (27) STUD PATTERN**

1  
2  
3  
4

STUD LOCATION	ORIGINAL LENGTH	FIRST PULL LENGTH (1) STRETCH (1)	SECOND PULL LENGTH (2) STRETCH(2)
1			
2			
3			
4			
5			
6			
7			
8			
9			
10			
11			
12			
13			
14			
15			
16			
17			
18			
19			
20			
21			
22			
23			
24			
25			
26			
27			

1  
2  
3  
4

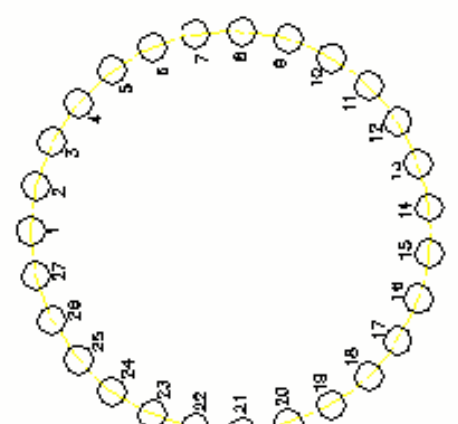

MACHINE \_\_\_\_\_  
 FLANGE \_\_\_\_\_  
 DATE \_\_\_\_\_  
 TECHNICIAN \_\_\_\_\_  
 SUPERVISOR \_\_\_\_\_

AVG. STRETCH \_\_\_\_\_  
 AVG. STRETCH \_\_\_\_\_  
 FINAL \_\_\_\_\_

UNITS in. mm, CIRCLE ONE

DATE \_\_\_\_\_  
 BY \_\_\_\_\_  
 CHK. APPROVAL \_\_\_\_\_  
 PWD \_\_\_\_\_

**Riverhawk**  
 215 CLINTON ROAD  
 NEW HARTFORD, NEW YORK 13418

**TORQUE PATTERN FOR (27) STUDS**  
 030915-01



215 Clinton Road.  
 New Hartford, NY 13413  
 Tel: 315-768-4855  
 Fax: 315-768-4941  
 Email: info@riverhawk.com

GE DRAWING NUMBER	REV.
373A4008	S
FIRST MADE FOR:	SH.

Instruction Manual IM-101  
 For Gas and Steam Turbine Tensioned Studs & Nuts

**STRETCH RECORD SHEET FOR (27) STUD PATTERN**

4
3
2
1

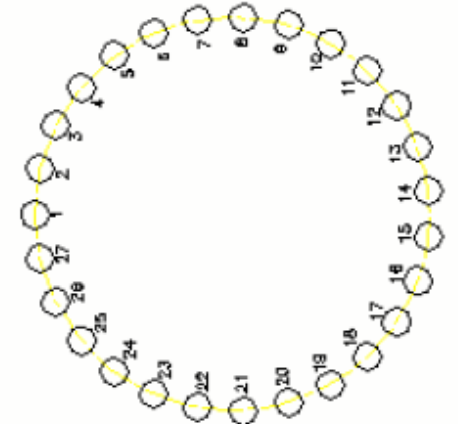

MACHINE \_\_\_\_\_  
 FLANGE \_\_\_\_\_  
 DATE \_\_\_\_\_  
 TECHNICIAN \_\_\_\_\_  
 SUPERVISOR \_\_\_\_\_

STUD LOCATION	ORIGINAL LENGTH	FIRST PULL LENGTH (1) STRETCH (1)	SECOND PULL LENGTH (2) STRETCH (2)	AVG. STRETCH	AVG. STRETCH FINAL
1	_____	_____	_____	_____	_____
2	_____	_____	_____	_____	_____
3	_____	_____	_____	_____	_____
4	_____	_____	_____	_____	_____
5	_____	_____	_____	_____	_____
6	_____	_____	_____	_____	_____
7	_____	_____	_____	_____	_____
8	_____	_____	_____	_____	_____
9	_____	_____	_____	_____	_____
10	_____	_____	_____	_____	_____
11	_____	_____	_____	_____	_____
12	_____	_____	_____	_____	_____
13	_____	_____	_____	_____	_____
14	_____	_____	_____	_____	_____
15	_____	_____	_____	_____	_____
16	_____	_____	_____	_____	_____
17	_____	_____	_____	_____	_____
18	_____	_____	_____	_____	_____
19	_____	_____	_____	_____	_____
20	_____	_____	_____	_____	_____
21	_____	_____	_____	_____	_____
22	_____	_____	_____	_____	_____
23	_____	_____	_____	_____	_____
24	_____	_____	_____	_____	_____
25	_____	_____	_____	_____	_____
26	_____	_____	_____	_____	_____
27	_____	_____	_____	_____	_____

UNITS in. mm, CIRCLE ONE

4
3
2
1

THE INFORMATION CONTAINED ON THIS SHEET IS THE PROPERTY OF RIVERHAWK COMPANY AND MAY NOT BE COPIED, USED FOR MANUFACTURE, USED FOR REPAIR OF OTHER COMPONENTS OR FURNISHED TO ANY OTHER PARTY WITHOUT EXPRESS PERMISSION FROM RIVERHAWK COMPANY.

DATE: \_\_\_\_\_ TIME: \_\_\_\_\_

DRAWN BY: \_\_\_\_\_

CHECKED BY: \_\_\_\_\_



RIVERHAWK COMPANY  
 215 CLINTON ROAD  
 NEW HARTFORD, NEW YORK 13413

TOLL FREE: 1-800-368-4444  
 TEL: 315-768-4855  
 FAX: 315-768-4941  
 E-MAIL: info@riverhawk.com

TORQUE PATTERN FOR (27) STUDS  
 PART NO. 030915-01



215 Clinton Road.  
 New Hartford, NY 13413  
 Tel: 315-768-4855  
 Fax: 315-768-4941  
 Email: info@riverhawk.com

GE DRAWING NUMBER	REV.
373A4008	S
FIRST MADE FOR:	SH.

**Instruction Manual IM-101**  
**For Gas and Steam Turbine Tensioned Studs & Nuts**

1																															
2																															
3																															
4																															
D	C	B	A																												
<table border="1" style="width:100%; border-collapse: collapse;"> <tr> <td style="width:10%;"></td> <td style="width:10%;"></td> <td style="width:10%;"></td> <td style="width:10%;"></td> <td style="width:10%;"></td> <td style="width:10%;"></td> <td style="width:10%;"></td> <td style="width:10%;"></td> </tr> <tr> <td>REV</td> <td>BY</td> <td>DATE</td> <td>REV</td> <td>DATE</td> <td>REV</td> <td>DATE</td> <td>REV</td> </tr> <tr> <td>A</td> <td>X</td> <td>SCALE CHART LARGER</td> <td></td> <td>11/25/96</td> <td></td> <td></td> <td></td> </tr> </table>																REV	BY	DATE	REV	DATE	REV	DATE	REV	A	X	SCALE CHART LARGER		11/25/96			
REV	BY	DATE	REV	DATE	REV	DATE	REV																								
A	X	SCALE CHART LARGER		11/25/96																											
<table border="1" style="width:100%; border-collapse: collapse;"> <tr> <td style="width:10%;"></td> <td style="width:10%;"></td> <td style="width:10%;"></td> <td style="width:10%;"></td> <td style="width:10%;"></td> <td style="width:10%;"></td> <td style="width:10%;"></td> <td style="width:10%;"></td> </tr> <tr> <td>DATE</td> <td>BY</td> <td>DATE</td> <td>DATE</td> <td>DATE</td> <td>DATE</td> <td>DATE</td> <td>DATE</td> </tr> <tr> <td></td> <td></td> <td></td> <td></td> <td></td> <td></td> <td></td> <td></td> </tr> </table>																DATE	BY	DATE	DATE	DATE	DATE	DATE	DATE								
DATE	BY	DATE	DATE	DATE	DATE	DATE	DATE																								
<table border="1" style="width:100%; border-collapse: collapse;"> <tr> <td style="width:10%;"></td> <td style="width:10%;"></td> <td style="width:10%;"></td> <td style="width:10%;"></td> <td style="width:10%;"></td> <td style="width:10%;"></td> <td style="width:10%;"></td> <td style="width:10%;"></td> </tr> <tr> <td>DATE</td> <td>BY</td> <td>DATE</td> <td>DATE</td> <td>DATE</td> <td>DATE</td> <td>DATE</td> <td>DATE</td> </tr> <tr> <td></td> <td></td> <td></td> <td></td> <td></td> <td></td> <td></td> <td></td> </tr> </table>																DATE	BY	DATE	DATE	DATE	DATE	DATE	DATE								
DATE	BY	DATE	DATE	DATE	DATE	DATE	DATE																								
<table border="1" style="width:100%; border-collapse: collapse;"> <tr> <td style="width:10%;"></td> <td style="width:10%;"></td> <td style="width:10%;"></td> <td style="width:10%;"></td> <td style="width:10%;"></td> <td style="width:10%;"></td> <td style="width:10%;"></td> <td style="width:10%;"></td> </tr> <tr> <td>DATE</td> <td>BY</td> <td>DATE</td> <td>DATE</td> <td>DATE</td> <td>DATE</td> <td>DATE</td> <td>DATE</td> </tr> <tr> <td></td> <td></td> <td></td> <td></td> <td></td> <td></td> <td></td> <td></td> </tr> </table>																DATE	BY	DATE	DATE	DATE	DATE	DATE	DATE								
DATE	BY	DATE	DATE	DATE	DATE	DATE	DATE																								
<table border="1" style="width:100%; border-collapse: collapse;"> <tr> <td style="width:10%;"></td> <td style="width:10%;"></td> <td style="width:10%;"></td> <td style="width:10%;"></td> <td style="width:10%;"></td> <td style="width:10%;"></td> <td style="width:10%;"></td> <td style="width:10%;"></td> </tr> <tr> <td>DATE</td> <td>BY</td> <td>DATE</td> <td>DATE</td> <td>DATE</td> <td>DATE</td> <td>DATE</td> <td>DATE</td> </tr> <tr> <td></td> <td></td> <td></td> <td></td> <td></td> <td></td> <td></td> <td></td> </tr> </table>																DATE	BY	DATE	DATE	DATE	DATE	DATE	DATE								
DATE	BY	DATE	DATE	DATE	DATE	DATE	DATE																								
<table border="1" style="width:100%; border-collapse: collapse;"> <tr> <td style="width:10%;"></td> <td style="width:10%;"></td> <td style="width:10%;"></td> <td style="width:10%;"></td> <td style="width:10%;"></td> <td style="width:10%;"></td> <td style="width:10%;"></td> <td style="width:10%;"></td> </tr> <tr> <td>DATE</td> <td>BY</td> <td>DATE</td> <td>DATE</td> <td>DATE</td> <td>DATE</td> <td>DATE</td> <td>DATE</td> </tr> <tr> <td></td> <td></td> <td></td> <td></td> <td></td> <td></td> <td></td> <td></td> </tr> </table>																DATE	BY	DATE	DATE	DATE	DATE	DATE	DATE								
DATE	BY	DATE	DATE	DATE	DATE	DATE	DATE																								
<table border="1" style="width:100%; border-collapse: collapse;"> <tr> <td style="width:10%;"></td> <td style="width:10%;"></td> <td style="width:10%;"></td> <td style="width:10%;"></td> <td style="width:10%;"></td> <td style="width:10%;"></td> <td style="width:10%;"></td> <td style="width:10%;"></td> </tr> <tr> <td>DATE</td> <td>BY</td> <td>DATE</td> <td>DATE</td> <td>DATE</td> <td>DATE</td> <td>DATE</td> <td>DATE</td> </tr> <tr> <td></td> <td></td> <td></td> <td></td> <td></td> <td></td> <td></td> <td></td> </tr> </table>																DATE	BY	DATE	DATE	DATE	DATE	DATE	DATE								
DATE	BY	DATE	DATE	DATE	DATE	DATE	DATE																								
<table border="1" style="width:100%; border-collapse: collapse;"> <tr> <td style="width:10%;"></td> <td style="width:10%;"></td> <td style="width:10%;"></td> <td style="width:10%;"></td> <td style="width:10%;"></td> <td style="width:10%;"></td> <td style="width:10%;"></td> <td style="width:10%;"></td> </tr> <tr> <td>DATE</td> <td>BY</td> <td>DATE</td> <td>DATE</td> <td>DATE</td> <td>DATE</td> <td>DATE</td> <td>DATE</td> </tr> <tr> <td></td> <td></td> <td></td> <td></td> <td></td> <td></td> <td></td> <td></td> </tr> </table>																DATE	BY	DATE	DATE	DATE	DATE	DATE	DATE								
DATE	BY	DATE	DATE	DATE	DATE	DATE	DATE																								
<table border="1" style="width:100%; border-collapse: collapse;"> <tr> <td style="width:10%;"></td> <td style="width:10%;"></td> <td style="width:10%;"></td> <td style="width:10%;"></td> <td style="width:10%;"></td> <td style="width:10%;"></td> <td style="width:10%;"></td> <td style="width:10%;"></td> </tr> <tr> <td>DATE</td> <td>BY</td> <td>DATE</td> <td>DATE</td> <td>DATE</td> <td>DATE</td> <td>DATE</td> <td>DATE</td> </tr> <tr> <td></td> <td></td> <td></td> <td></td> <td></td> <td></td> <td></td> <td></td> </tr> </table>																DATE	BY	DATE	DATE	DATE	DATE	DATE	DATE								
DATE	BY	DATE	DATE	DATE	DATE	DATE	DATE																								
<table border="1" style="width:100%; border-collapse: collapse;"> <tr> <td style="width:10%;"></td> <td style="width:10%;"></td> <td style="width:10%;"></td> <td style="width:10%;"></td> <td style="width:10%;"></td> <td style="width:10%;"></td> <td style="width:10%;"></td> <td style="width:10%;"></td> </tr> <tr> <td>DATE</td> <td>BY</td> <td>DATE</td> <td>DATE</td> <td>DATE</td> <td>DATE</td> <td>DATE</td> <td>DATE</td> </tr> <tr> <td></td> <td></td> <td></td> <td></td> <td></td> <td></td> <td></td> <td></td> </tr> </table>																DATE	BY	DATE	DATE	DATE	DATE	DATE	DATE								
DATE	BY	DATE	DATE	DATE	DATE	DATE	DATE																								
<table border="1" style="width:100%; border-collapse: collapse;"> <tr> <td style="width:10%;"></td> <td style="width:10%;"></td> <td style="width:10%;"></td> <td style="width:10%;"></td> <td style="width:10%;"></td> <td style="width:10%;"></td> <td style="width:10%;"></td> <td style="width:10%;"></td> </tr> <tr> <td>DATE</td> <td>BY</td> <td>DATE</td> <td>DATE</td> <td>DATE</td> <td>DATE</td> <td>DATE</td> <td>DATE</td> </tr> <tr> <td></td> <td></td> <td></td> <td></td> <td></td> <td></td> <td></td> <td></td> </tr> </table>																DATE	BY	DATE	DATE	DATE	DATE	DATE	DATE								
DATE	BY	DATE	DATE	DATE	DATE	DATE	DATE																								
<table border="1" style="width:100%; border-collapse: collapse;"> <tr> <td style="width:10%;"></td> <td style="width:10%;"></td> <td style="width:10%;"></td> <td style="width:10%;"></td> <td style="width:10%;"></td> <td style="width:10%;"></td> <td style="width:10%;"></td> <td style="width:10%;"></td> </tr> <tr> <td>DATE</td> <td>BY</td> <td>DATE</td> <td>DATE</td> <td>DATE</td> <td>DATE</td> <td>DATE</td> <td>DATE</td> </tr> <tr> <td></td> <td></td> <td></td> <td></td> <td></td> <td></td> <td></td> <td></td> </tr> </table>																DATE	BY	DATE	DATE	DATE	DATE	DATE	DATE								
DATE	BY	DATE	DATE	DATE	DATE	DATE	DATE																								
<table border="1" style="width:100%; border-collapse: collapse;"> <tr> <td style="width:10%;"></td> <td style="width:10%;"></td> <td style="width:10%;"></td> <td style="width:10%;"></td> <td style="width:10%;"></td> <td style="width:10%;"></td> <td style="width:10%;"></td> <td style="width:10%;"></td> </tr> <tr> <td>DATE</td> <td>BY</td> <td>DATE</td> <td>DATE</td> <td>DATE</td> <td>DATE</td> <td>DATE</td> <td>DATE</td> </tr> <tr> <td></td> <td></td> <td></td> <td></td> <td></td> <td></td> <td></td> <td></td> </tr> </table>																DATE	BY	DATE	DATE	DATE	DATE	DATE	DATE								
DATE	BY	DATE	DATE	DATE	DATE	DATE	DATE																								
<table border="1" style="width:100%; border-collapse: collapse;"> <tr> <td style="width:10%;"></td> <td style="width:10%;"></td> <td style="width:10%;"></td> <td style="width:10%;"></td> <td style="width:10%;"></td> <td style="width:10%;"></td> <td style="width:10%;"></td> <td style="width:10%;"></td> </tr> <tr> <td>DATE</td> <td>BY</td> <td>DATE</td> <td>DATE</td> <td>DATE</td> <td>DATE</td> <td>DATE</td> <td>DATE</td> </tr> <tr> <td></td> <td></td> <td></td> <td></td> <td></td> <td></td> <td></td> <td></td> </tr> </table>																DATE	BY	DATE	DATE	DATE	DATE	DATE	DATE								
DATE	BY	DATE	DATE	DATE	DATE	DATE	DATE																								
<table border="1" style="width:100%; border-collapse: collapse;"> <tr> <td style="width:10%;"></td> <td style="width:10%;"></td> <td style="width:10%;"></td> <td style="width:10%;"></td> <td style="width:10%;"></td> <td style="width:10%;"></td> <td style="width:10%;"></td> <td style="width:10%;"></td> </tr> <tr> <td>DATE</td> <td>BY</td> <td>DATE</td> <td>DATE</td> <td>DATE</td> <td>DATE</td> <td>DATE</td> <td>DATE</td> </tr> <tr> <td></td> <td></td> <td></td> <td></td> <td></td> <td></td> <td></td> <td></td> </tr> </table>																DATE	BY	DATE	DATE	DATE	DATE	DATE	DATE								
DATE	BY	DATE	DATE	DATE	DATE	DATE	DATE																								
<table border="1" style="width:100%; border-collapse: collapse;"> <tr> <td style="width:10%;"></td> <td style="width:10%;"></td> <td style="width:10%;"></td> <td style="width:10%;"></td> <td style="width:10%;"></td> <td style="width:10%;"></td> <td style="width:10%;"></td> <td style="width:10%;"></td> </tr> <tr> <td>DATE</td> <td>BY</td> <td>DATE</td> <td>DATE</td> <td>DATE</td> <td>DATE</td> <td>DATE</td> <td>DATE</td> </tr> <tr> <td></td> <td></td> <td></td> <td></td> <td></td> <td></td> <td></td> <td></td> </tr> </table>																DATE	BY	DATE	DATE	DATE	DATE	DATE	DATE								
DATE	BY	DATE	DATE	DATE	DATE	DATE	DATE																								
<table border="1" style="width:100%; border-collapse: collapse;"> <tr> <td style="width:10%;"></td> <td style="width:10%;"></td> <td style="width:10%;"></td> <td style="width:10%;"></td> <td style="width:10%;"></td> <td style="width:10%;"></td> <td style="width:10%;"></td> <td style="width:10%;"></td> </tr> <tr> <td>DATE</td> <td>BY</td> <td>DATE</td> <td>DATE</td> <td>DATE</td> <td>DATE</td> <td>DATE</td> <td>DATE</td> </tr> <tr> <td></td> <td></td> <td></td> <td></td> <td></td> <td></td> <td></td> <td></td> </tr> </table>																DATE	BY	DATE	DATE	DATE	DATE	DATE	DATE								
DATE	BY	DATE	DATE	DATE	DATE	DATE	DATE																								
<table border="1" style="width:100%; border-collapse: collapse;"> <tr> <td style="width:10%;"></td> <td style="width:10%;"></td> <td style="width:10%;"></td> <td style="width:10%;"></td> <td style="width:10%;"></td> <td style="width:10%;"></td> <td style="width:10%;"></td> <td style="width:10%;"></td> </tr> <tr> <td>DATE</td> <td>BY</td> <td>DATE</td> <td>DATE</td> <td>DATE</td> <td>DATE</td> <td>DATE</td> <td>DATE</td> </tr> <tr> <td></td> <td></td> <td></td> <td></td> <td></td> <td></td> <td></td> <td></td> </tr> </table>																DATE	BY	DATE	DATE	DATE	DATE	DATE	DATE								
DATE	BY	DATE	DATE	DATE	DATE	DATE	DATE																								
<table border="1" style="width:100%; border-collapse: collapse;"> <tr> <td style="width:10%;"></td> <td style="width:10%;"></td> <td style="width:10%;"></td> <td style="width:10%;"></td> <td style="width:10%;"></td> <td style="width:10%;"></td> <td style="width:10%;"></td> <td style="width:10%;"></td> </tr> <tr> <td>DATE</td> <td>BY</td> <td>DATE</td> <td>DATE</td> <td>DATE</td> <td>DATE</td> <td>DATE</td> <td>DATE</td> </tr> <tr> <td></td> <td></td> <td></td> <td></td> <td></td> <td></td> <td></td> <td></td> </tr> </table>																DATE	BY	DATE	DATE	DATE	DATE	DATE	DATE								
DATE	BY	DATE	DATE	DATE	DATE	DATE	DATE																								
<table border="1" style="width:100%; border-collapse: collapse;"> <tr> <td style="width:10%;"></td> <td style="width:10%;"></td> <td style="width:10%;"></td> <td style="width:10%;"></td> <td style="width:10%;"></td> <td style="width:10%;"></td> <td style="width:10%;"></td> <td style="width:10%;"></td> </tr> <tr> <td>DATE</td> <td>BY</td> <td>DATE</td> <td>DATE</td> <td>DATE</td> <td>DATE</td> <td>DATE</td> <td>DATE</td> </tr> <tr> <td></td> <td></td> <td></td> <td></td> <td></td> <td></td> <td></td> <td></td> </tr> </table>																DATE	BY	DATE	DATE	DATE	DATE	DATE	DATE								
DATE	BY	DATE	DATE	DATE	DATE	DATE	DATE																								
<table border="1" style="width:100%; border-collapse: collapse;"> <tr> <td style="width:10%;"></td> <td style="width:10%;"></td> <td style="width:10%;"></td> <td style="width:10%;"></td> <td style="width:10%;"></td> <td style="width:10%;"></td> <td style="width:10%;"></td> <td style="width:10%;"></td> </tr> <tr> <td>DATE</td> <td>BY</td> <td>DATE</td> <td>DATE</td> <td>DATE</td> <td>DATE</td> <td>DATE</td> <td>DATE</td> </tr> <tr> <td></td> <td></td> <td></td> <td></td> <td></td> <td></td> <td></td> <td></td> </tr> </table>																DATE	BY	DATE	DATE	DATE	DATE	DATE	DATE								
DATE	BY	DATE	DATE	DATE	DATE	DATE	DATE																								
<table border="1" style="width:100%; border-collapse: collapse;"> <tr> <td style="width:10%;"></td> <td style="width:10%;"></td> <td style="width:10%;"></td> <td style="width:10%;"></td> <td style="width:10%;"></td> <td style="width:10%;"></td> <td style="width:10%;"></td> <td style="width:10%;"></td> </tr> <tr> <td>DATE</td> <td>BY</td> <td>DATE</td> <td>DATE</td> <td>DATE</td> <td>DATE</td> <td>DATE</td> <td>DATE</td> </tr> <tr> <td></td> <td></td> <td></td> <td></td> <td></td> <td></td> <td></td> <td></td> </tr> </table>																DATE	BY	DATE	DATE	DATE	DATE	DATE	DATE								
DATE	BY	DATE	DATE	DATE	DATE	DATE	DATE																								
<table border="1" style="width:100%; border-collapse: collapse;"> <tr> <td style="width:10%;"></td> <td style="width:10%;"></td> <td style="width:10%;"></td> <td style="width:10%;"></td> <td style="width:10%;"></td> <td style="width:10%;"></td> <td style="width:10%;"></td> <td style="width:10%;"></td> </tr> <tr> <td>DATE</td> <td>BY</td> <td>DATE</td> <td>DATE</td> <td>DATE</td> <td>DATE</td> <td>DATE</td> <td>DATE</td> </tr> <tr> <td></td> <td></td> <td></td> <td></td> <td></td> <td></td> <td></td> <td></td> </tr> </table>																DATE	BY	DATE	DATE	DATE	DATE	DATE	DATE								
DATE	BY	DATE	DATE	DATE	DATE	DATE	DATE																								
<table border="1" style="width:100%; border-collapse: collapse;"> <tr> <td style="width:10%;"></td> <td style="width:10%;"></td> <td style="width:10%;"></td> <td style="width:10%;"></td> <td style="width:10%;"></td> <td style="width:10%;"></td> <td style="width:10%;"></td> <td style="width:10%;"></td> </tr> <tr> <td>DATE</td> <td>BY</td> <td>DATE</td> <td>DATE</td> <td>DATE</td> <td>DATE</td> <td>DATE</td> <td>DATE</td> </tr> <tr> <td></td> <td></td> <td></td> <td></td> <td></td> <td></td> <td></td> <td></td> </tr> </table>																DATE	BY	DATE	DATE	DATE	DATE	DATE	DATE								
DATE	BY	DATE	DATE	DATE	DATE	DATE	DATE																								
<table border="1" style="width:100%; border-collapse: collapse;"> <tr> <td style="width:10%;"></td> <td style="width:10%;"></td> <td style="width:10%;"></td> <td style="width:10%;"></td> <td style="width:10%;"></td> <td style="width:10%;"></td> <td style="width:10%;"></td> <td style="width:10%;"></td> </tr> <tr> <td>DATE</td> <td>BY</td> <td>DATE</td> <td>DATE</td> <td>DATE</td> <td>DATE</td> <td>DATE</td> <td>DATE</td> </tr> <tr> <td></td> <td></td> <td></td> <td></td> <td></td> <td></td> <td></td> <td></td> </tr> </table>																DATE	BY	DATE	DATE	DATE	DATE	DATE	DATE								
DATE	BY	DATE	DATE	DATE	DATE	DATE	DATE																								
<table border="1" style="width:100%; border-collapse: collapse;"> <tr> <td style="width:10%;"></td> <td style="width:10%;"></td> <td style="width:10%;"></td> <td style="width:10%;"></td> <td style="width:10%;"></td> <td style="width:10%;"></td> <td style="width:10%;"></td> <td style="width:10%;"></td> </tr> <tr> <td>DATE</td> <td>BY</td> <td>DATE</td> <td>DATE</td> <td>DATE</td> <td>DATE</td> <td>DATE</td> <td>DATE</td> </tr> <tr> <td></td> <td></td> <td></td> <td></td> <td></td> <td></td> <td></td> <td></td> </tr> </table>																DATE	BY	DATE	DATE	DATE	DATE	DATE	DATE								
DATE	BY	DATE	DATE	DATE	DATE	DATE	DATE																								
<table border="1" style="width:100%; border-collapse: collapse;"> <tr> <td style="width:10%;"></td> <td style="width:10%;"></td> <td style="width:10%;"></td> <td style="width:10%;"></td> <td style="width:10%;"></td> <td style="width:10%;"></td> <td style="width:10%;"></td> <td style="width:10%;"></td> </tr> <tr> <td>DATE</td> <td>BY</td> <td>DATE</td> <td>DATE</td> <td>DATE</td> <td>DATE</td> <td>DATE</td> <td>DATE</td> </tr> <tr> <td></td> <td></td> <td></td> <td></td> <td></td> <td></td> <td></td> <td></td> </tr> </table>																DATE	BY	DATE	DATE	DATE	DATE	DATE	DATE								
DATE	BY	DATE	DATE	DATE	DATE	DATE	DATE																								
<table border="1" style="width:100%; border-collapse: collapse;"> <tr> <td style="width:10%;"></td> <td style="width:10%;"></td> <td style="width:10%;"></td> <td style="width:10%;"></td> <td style="width:10%;"></td> <td style="width:10%;"></td> <td style="width:10%;"></td> <td style="width:10%;"></td> </tr> <tr> <td>DATE</td> <td>BY</td> <td>DATE</td> <td>DATE</td> <td>DATE</td> <td>DATE</td> <td>DATE</td> <td>DATE</td> </tr> <tr> <td></td> <td></td> <td></td> <td></td> <td></td> <td></td> <td></td> <td></td> </tr> </table>																DATE	BY	DATE	DATE	DATE	DATE	DATE	DATE								
DATE	BY	DATE	DATE	DATE	DATE	DATE	DATE																								
<table border="1" style="width:100%; border-collapse: collapse;"> <tr> <td style="width:10%;"></td> <td style="width:10%;"></td> <td style="width:10%;"></td> <td style="width:10%;"></td> <td style="width:10%;"></td> <td style="width:10%;"></td> <td style="width:10%;"></td> <td style="width:10%;"></td> </tr> <tr> <td>DATE</td> <td>BY</td> <td>DATE</td> <td>DATE</td> <td>DATE</td> <td>DATE</td> <td>DATE</td> <td>DATE</td> </tr> <tr> <td></td> <td></td> <td></td> <td></td> <td></td> <td></td> <td></td> <td></td> </tr> </table>																DATE	BY	DATE	DATE	DATE	DATE	DATE	DATE								
DATE	BY	DATE	DATE	DATE	DATE	DATE	DATE																								
<table border="1" style="width:100%; border-collapse: collapse;"> <tr> <td style="width:10%;"></td> <td style="width:10%;"></td> <td style="width:10%;"></td> <td style="width:10%;"></td> <td style="width:10%;"></td> <td style="width:10%;"></td> <td style="width:10%;"></td> <td style="width:10%;"></td> </tr> <tr> <td>DATE</td> <td>BY</td> <td>DATE</td> <td>DATE</td> <td>DATE</td> <td>DATE</td> <td>DATE</td> <td>DATE</td> </tr> <tr> <td></td> <td></td> <td></td> <td></td> <td></td> <td></td> <td></td> <td></td> </tr> </table>																DATE	BY	DATE	DATE	DATE	DATE	DATE	DATE								
DATE	BY	DATE	DATE	DATE	DATE	DATE	DATE																								
<table border="1" style="width:100%; border-collapse: collapse;"> <tr> <td style="width:10%;"></td> <td style="width:10%;"></td> <td style="width:10%;"></td> <td style="width:10%;"></td> <td style="width:10%;"></td> <td style="width:10%;"></td> <td style="width:10%;"></td> <td style="width:10%;"></td> </tr> <tr> <td>DATE</td> <td>BY</td> <td>DATE</td> <td>DATE</td> <td>DATE</td> <td>DATE</td> <td>DATE</td> <td>DATE</td> </tr> <tr> <td></td> <td></td> <td></td> <td></td> <td></td> <td></td> <td></td> <td></td> </tr> </table>																DATE	BY	DATE	DATE	DATE	DATE	DATE	DATE								
DATE	BY	DATE	DATE	DATE	DATE	DATE	DATE																								
<table border="1" style="width:100%; border-collapse: collapse;"> <tr> <td style="width:10%;"></td> <td style="width:10%;"></td> <td style="width:10%;"></td> <td style="width:10%;"></td> <td style="width:10%;"></td> <td style="width:10%;"></td> <td style="width:10%;"></td> <td style="width:10%;"></td> </tr> <tr> <td>DATE</td> <td>BY</td> <td>DATE</td> <td>DATE</td> <td>DATE</td> <td>DATE</td> <td>DATE</td> <td>DATE</td> </tr> <tr> <td></td> <td></td> <td></td> <td></td> <td></td> <td></td> <td></td> <td></td> </tr> </table>																DATE	BY	DATE	DATE	DATE	DATE	DATE	DATE								
DATE	BY	DATE	DATE	DATE	DATE	DATE	DATE																								
<table border="1" style="width:100%; border-collapse: collapse;"> <tr> <td style="width:10%;"></td> <td style="width:10%;"></td> <td style="width:10%;"></td> <td style="width:10%;"></td> <td style="width:10%;"></td> <td style="width:10%;"></td> <td style="width:10%;"></td> <td style="width:10%;"></td> </tr> <tr> <td>DATE</td> <td>BY</td> <td>DATE</td> <td>DATE</td> <td>DATE</td> <td>DATE</td> <td>DATE</td> <td>DATE</td> </tr> <tr> <td></td> <td></td> <td></td> <td></td> <td></td> <td></td> <td></td> <td></td> </tr> </table>																DATE	BY	DATE	DATE	DATE	DATE	DATE	DATE								
DATE	BY	DATE	DATE	DATE	DATE	DATE	DATE																								
<table border="1" style="width:100%; border-collapse: collapse;"> <tr> <td style="width:10%;"></td> <td style="width:10%;"></td> <td style="width:10%;"></td> <td style="width:10%;"></td> <td style="width:10%;"></td> <td style="width:10%;"></td> <td style="width:10%;"></td> <td style="width:10%;"></td> </tr> <tr> <td>DATE</td> <td>BY</td> <td>DATE</td> <td>DATE</td> <td>DATE</td> <td>DATE</td> <td>DATE</td> <td>DATE</td> </tr> <tr> <td></td> <td></td> <td></td> <td></td> <td></td> <td></td> <td></td> <td></td> </tr> </table>																DATE	BY	DATE	DATE	DATE	DATE	DATE	DATE								
DATE	BY	DATE	DATE	DATE	DATE	DATE	DATE																								
<table border="1" style="width:100%; border-collapse: collapse;"> <tr> <td style="width:10%;"></td> <td style="width:10%;"></td> <td style="width:10%;"></td> <td style="width:10%;"></td> <td style="width:10%;"></td> <td style="width:10%;"></td> <td style="width:10%;"></td> <td style="width:10%;"></td> </tr> <tr> <td>DATE</td> <td>BY</td> <td>DATE</td> <td>DATE</td> <td>DATE</td> <td>DATE</td> <td>DATE</td> <td>DATE</td> </tr> <tr> <td></td> <td></td> <td></td> <td></td> <td></td> <td></td> <td></td> <td></td> </tr> </table>																DATE	BY	DATE	DATE	DATE	DATE	DATE	DATE								
DATE	BY	DATE	DATE	DATE	DATE	DATE	DATE																								
<table border="1" style="width:100%; border-collapse: collapse;"> <tr> <td style="width:10%;"></td> <td style="width:10%;"></td> <td style="width:10%;"></td> <td style="width:10%;"></td> <td style="width:10%;"></td> <td style="width:10%;"></td> <td style="width:10%;"></td> <td style="width:10%;"></td> </tr> <tr> <td>DATE</td> <td>BY</td> <td>DATE</td> <td>DATE</td> <td>DATE</td> <td>DATE</td> <td>DATE</td> <td>DATE</td> </tr> <tr> <td></td> <td></td> <td></td> <td></td> <td></td> <td></td> <td></td> <td></td> </tr> </table>																DATE	BY	DATE	DATE	DATE	DATE	DATE	DATE								
DATE	BY	DATE	DATE	DATE	DATE	DATE	DATE																								
<table border="1" style="width:100%; border-collapse: collapse;"> <tr> <td style="width:10%;"></td> <td style="width:10%;"></td> <td style="width:10%;"></td> <td style="width:10%;"></td> <td style="width:10%;"></td> <td style="width:10%;"></td> <td style="width:10%;"></td> <td style="width:10%;"></td> </tr> <tr> <td>DATE</td> <td>BY</td> <td>DATE</td> <td>DATE</td> <td>DATE</td> <td>DATE</td> <td>DATE</td> <td>DATE</td> </tr> <tr> <td></td> <td></td> <td></td> <td></td> <td></td> <td></td> <td></td> <td></td> </tr> </table>																DATE	BY	DATE	DATE	DATE	DATE	DATE	DATE								
DATE	BY	DATE	DATE	DATE	DATE	DATE	DATE																								
<table border="1" style="width:100%; border-collapse: collapse;"> <tr> <td style="width:10%;"></td> <td style="width:10%;"></td> <td style="width:10%;"></td> <td style="width:10%;"></td> <td style="width:10%;"></td> <td style="width:10%;"></td> <td style="width:10%;"></td> <td style="width:10%;"></td> </tr> <tr> <td>DATE</td> <td>BY</td> <td>DATE</td> <td>DATE</td> <td>DATE</td> <td>DATE</td> <td>DATE</td> <td>DATE</td> </tr> <tr> <td></td> <td></td> <td></td> <td></td> <td></td> <td></td> <td></td> <td></td> </tr> </table>																DATE	BY	DATE	DATE	DATE	DATE	DATE	DATE								
DATE	BY	DATE	DATE	DATE	DATE	DATE	DATE																								
<table border="1" style="width:100%; border-collapse: collapse;"> <tr> <td style="width:10%;"></td> <td style="width:10%;"></td> <td style="width:10%;"></td> <td style="width:10%;"></td> <td style="width:10%;"></td> <td style="width:10%;"></td> <td style="width:10%;"></td> <td style="width:10%;"></td> </tr> <tr> <td>DATE</td> <td>BY</td> <td>DATE</td> <td>DATE</td> <td>DATE</td> <td>DATE</td> <td>DATE</td> <td>DATE</td> </tr> <tr> <td></td> <td></td> <td></td> <td></td> <td></td> <td></td> <td></td> <td></td> </tr> </table>																DATE	BY	DATE	DATE	DATE	DATE	DATE	DATE								
DATE	BY	DATE	DATE	DATE	DATE	DATE	DATE																								
<table border="1" style="width:100%; border-collapse: collapse;"> <tr> <td style="width:10%;"></td> <td style="width:10%;"></td> <td style="width:10%;"></td> <td style="width:10%;"></td> <td style="width:10%;"></td> <td style="width:10%;"></td> <td style="width:10%;"></td> <td style="width:10%;"></td> </tr> <tr> <td>DATE</td> <td>BY</td> <td>DATE</td> <td>DATE</td> <td>DATE</td> <td>DATE</td> <td>DATE</td> <td>DATE</td> </tr> <tr> <td></td> <td></td> <td></td> <td></td> <td></td> <td></td> <td></td> <td></td> </tr> </table>																DATE	BY	DATE	DATE	DATE	DATE	DATE	DATE								
DATE	BY	DATE	DATE	DATE	DATE	DATE	DATE																								
<table border="1" style="width:100%; border-collapse: collapse;"> <tr> <td style="width:10%;"></td> <td style="width:10%;"></td> <td style="width:10%;"></td> <td style="width:10%;"></td> <td style="width:10%;"></td> <td style="width:10%;"></td> <td style="width:10%;"></td> <td style="width:10%;"></td> </tr> <tr> <td>DATE</td> <td>BY</td> <td>DATE</td> <td>DATE</td> <td>DATE</td> <td>DATE</td> <td>DATE</td> <td>DATE</td> </tr> <tr> <td></td> <td></td> <td></td> <td></td> <td></td> <td></td> <td></td> <td></td> </tr> </table>																DATE	BY	DATE	DATE	DATE	DATE	DATE	DATE								
DATE	BY	DATE	DATE	DATE	DATE	DATE	DATE																								
<table border="1" style="width:100%; border-collapse: collapse;"> <tr> <td style="width:10%;"></td> <td style="width:10%;"></td> <td style="width:10%;"></td> <td style="width:10%;"></td> <td style="width:10%;"></td> <td style="width:10%;"></td> <td style="width:10%;"></td> <td style="width:10%;"></td> </tr> <tr> <td>DATE</td> <td>BY</td> <td>DATE</td> <td>DATE</td> <td>DATE</td> <td>DATE</td> <td>DATE</td> <td>DATE</td> </tr> <tr> <td></td> <td></td> <td></td> <td></td> <td></td> <td></td> <td></td> <td></td> </tr> </table>																DATE	BY	DATE	DATE	DATE	DATE	DATE	DATE								
DATE	BY	DATE	DATE	DATE	DATE	DATE	DATE																								
<table border="1" style="width:100%; border-collapse: collapse;"> <tr> <td style="width:10%;"></td> <td style="width:10%;"></td> <td style="width:10%;"></td> <td style="width:10%;"></td> <td style="width:10%;"></td> <td style="width:10%;"></td> <td style="width:10%;"></td> <td style="width:10%;"></td> </tr> <tr> <td>DATE</td> <td>BY</td> <td>DATE</td> <td>DATE</td> <td>DATE</td> <td>DATE</td> <td>DATE</td> <td>DATE</td> </tr> <tr> <td></td> <td></td> <td></td> <td></td> <td></td> <td></td> <td></td> <td></td> </tr> </table>																DATE	BY	DATE	DATE	DATE	DATE	DATE	DATE								
DATE	BY	DATE	DATE	DATE	DATE	DATE	DATE																								
<table border="1" style="width:100%; border-collapse: collapse;"> <tr> <td style="width:10%;"></td> <td style="width:10%;"></td> <td style="width:10%;"></td> <td style="width:10%;"></td> <td style="width:10%;"></td> <td style="width:10%;"></td> <td style="width:10%;"></td> <td style="width:10%;"></td> </tr> <tr> <td>DATE</td> <td>BY</td> <td>DATE</td> <td>DATE</td> <td>DATE</td> <td>DATE</td> <td>DATE</td> <td>DATE</td> </tr> <tr> <td></td> <td></td> <td></td> <td></td> <td></td> <td></td> <td></td> <td></td> </tr> </table>																DATE	BY	DATE	DATE	DATE	DATE	DATE	DATE								
DATE	BY	DATE	DATE	DATE	DATE	DATE	DATE																								
<table border="1" style="width:100%; border-collapse: collapse;"> <tr> <td style="width:10%;"></td> <td style="width:10%;"></td> <td style="width:10%;"></td> <td style="width:10%;"></td> <td style="width:10%;"></td> <td style="width:10%;"></td> <td style="width:10%;"></td> <td style="width:10%;"></td> </tr> <tr> <td>DATE</td> <td>BY</td> <td>DATE</td> <td>DATE</td> <td>DATE</td> <td>DATE</td> <td>DATE</td> <td>DATE</td> </tr> <tr> <td></td> <td></td> <td></td> <td></td> <td></td> <td></td> <td></td> <td></td> </tr> </table>																DATE	BY	DATE	DATE	DATE	DATE	DATE	DATE								
DATE	BY	DATE	DATE	DATE	DATE	DATE	DATE																								
<table border="1" style="width:100%; border-collapse: collapse;"> <tr> <td style="width:10%;"></td> <td style="width:10%;"></td> <td style="width:10%;"></td> <td style="width:10%;"></td> <td style="width:10%;"></td> <td style="width:10%;"></td> <td style="width:10%;"></td> <td style="width:10%;"></td> </tr> <tr> <td>DATE</td> <td>BY</td> <td>DATE</td> <td>DATE</td> <td>DATE</td> <td>DATE</td> <td>DATE</td> <td>DATE</td> </tr> <tr> <td></td> <td></td> <td></td> <td></td> <td></td> <td></td> <td></td> <td></td> </tr> </table>																DATE	BY	DATE	DATE	DATE	DATE	DATE	DATE								
DATE	BY	DATE	DATE	DATE	DATE	DATE	DATE																								
<table border="1" style="width:100%; border-collapse: collapse;"> <tr> <td style="width:10%;"></td> <td style="width:10%;"></td> <td style="width:10%;"></td> <td style="width:10%;"></td> <td style="width:10%;"></td> <td style="width:10%;"></td> <td style="width:10%;"></td> <td style="width:10%;"></td> </tr> <tr> <td>DATE</td> <td>BY</td> <td>DATE</td> <td>DATE</td> <td>DATE</td> <td>DATE</td> <td>DATE</td> <td>DATE</td> </tr> <tr> <td></td> <td></td> <td></td> <td></td> <td></td> <td></td> <td></td> <td></td> </tr> </table>																DATE	BY	DATE	DATE	DATE	DATE	DATE	DATE								
DATE	BY	DATE	DATE	DATE	DATE	DATE	DATE																								